

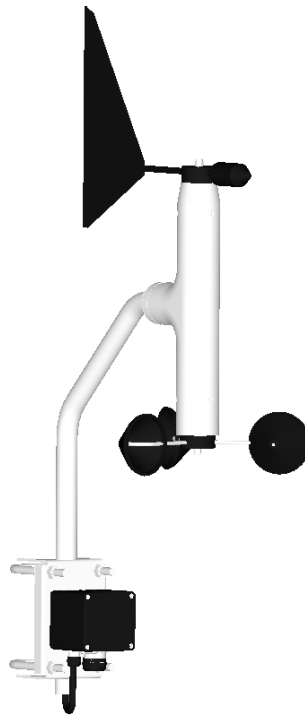

# **OBSERVATOR**

*instruments*

## **OMC-160-3**



### **OMC-160-3 Anemometer**

### **Manual**

**Version 3.4 – April 2024**

Author: Observer Instruments

*Revisions:*

2.04	(November 2013)	previous versions OMC-160-2
3.0	(May 2017)	OMC-160-3 introduction
3.1	(August 2017)	OMC-160-3 reviewed manual
3.2	(November 2017)	Update specifications
3.3	(November 2019)	Update power requirements
3.4	(April 2024)	Update EU Declaration of Conformity

## Index

1	Introduction .....	5
2	Safety .....	6
3	Description .....	7
3.1	General description.....	7
3.2	Main parts .....	7
3.3	Moving parts .....	7
3.4	Theory of Operation .....	7
3.5	Conditions of use .....	7
3.6	Field use examples.....	8
4	Installation.....	8
4.1	Unpacking.....	8
4.2	Location of the sensor .....	8
4.3	Site preparation .....	9
4.4	Mounting / mechanical installation.....	9
4.5	Assembly of cup and vane.....	9
4.6	Electrical installation .....	11
4.6.1	Connections.....	11
4.6.2	Alignment LED's .....	12
4.6.3	Status LED's.....	12
5	Commissioning .....	13
5.1	Commissioning procedure .....	13
5.1.1	Alignment of the wind vane .....	13
6	Maintenance .....	15
6.1	Maintenance schedule (preventive maintenance) .....	15
6.2	Removing the OMC-160 anemometer from its location .....	15
6.3	Recalibration .....	15
6.4	Opening and closing the anemometer.....	16
6.5	Replacement of ball bearings and sensor PCB's .....	16
7	Data protocol.....	19
7.1	General .....	19
7.2	Baudrate .....	19
7.3	Messages.....	19
8	Specifications.....	20
8.1	Specifications.....	20
9	Support, service and warranty .....	21
10	Handling, transportation and storage .....	22
10.1	Handling.....	22
10.2	Long term storage.....	22
10.3	Reshipping the instrument.....	22
11	Advanced configuration.....	23
12	Dimensional Drawing .....	24
13	EU Declaration of Conformity.....	25

*Page intentionally left blank*

## 1 Introduction

---

The Observator OMC-160-3 is the 3<sup>rd</sup> generation of this popular anemometer. The sensor is often mounted in harsh conditions of the marine and offshore environment and it has proven to be robust and reliable over the years. The OMC-160-3 continues the robust build quality improved with the latest technology, which will make it even more reliable and easier to commission.

This manual is intended for the engineer doing the installation and commissioning and can also be used as reference for the operator.

## 2 Safety



For correct functioning the Observator OMC-160 Anemometer must be installed and commissioned according installation & commissioning instructions by a qualified engineer.



The Observator OMC-160 Anemometer has moving parts, which can rotate fast during strong winds. Keep clear of the cup and vane during strong winds!



The Observator OMC-160 Anemometer is usually installed at height. Technicians maintaining the system need to be qualified to work at those heights whenever applicable!



Remember: instruments are tools. They do NOT replace your own observations!



After end of life dispose this product according local regulations or return to manufacturer.

---

## 3 Description

### 3.1 General description

The Observator OMC-160-3 is a combined wind speed and direction meter using high accurate non-contact sensors. It uses a rotary cup with 3 cups for speed and a stainless steel balanced vane for direction measurement. It has a NMEA output signal and be combined with all Observator display and Meteolink systems.

### 3.2 Main parts

The OMC-160 anemometer consists of a sensor body and a mounting bracket. Note that the mounting bracket, though it was sometimes referred to as OMC-167, is an integral part of the OMC-160 anemometer. The mounting bracket has a mast clamp for mechanical connection and a junction box for electrical connection. This clamp is designed for mounting on a vertical pipe end.

### 3.3 Moving parts

The only moving parts are the cup unit and the vane unit. The vane unit is mounted on top of the sensor body, and the cup unit is mounted at the bottom of the sensor body. Both the cup unit and the vane unit are wind driven. The wind speed sensor is a rotary cup type unit manufactured in stainless steel and polycarbonate. The three cups are cone shaped for optimum response to varying winds. The vane unit is made in stainless steel.

### 3.4 Theory of Operation

The OMC-160 is a cup and vane anemometer. Cup and vane anemometers are the most common instrumentation for measurement of wind speed and direction. Cup and vane anemometers are the primary sensors for wind measurement used by the leading meteorological services all over the world. Therefore the readings of the OMC-160 anemometer are inter-comparable with the readings of other cup and vane anemometers without any conversions.

For a more comprehensive discussion on the measurement principle please refer to Chapter 5 of the WMO CIMO guide<sup>1</sup>

### 3.5 Conditions of use.

The OMC-160 anemometer is built to provide reliable measurement results under all weather conditions. Rain, snow, or other kinds of precipitation do not affect the readings. Further, the OMC-160 anemometer is insensitive to noise, extreme temperatures, solar radiation, etc.

---

<sup>1</sup> *Guide to Meteorological Instruments and Methods of Observation, WMO No. 8, 7th Edition, World Meteorological Organisation, Geneva, Switzerland, ISBN 92-63-16008-2*

### 3.6 Field use examples

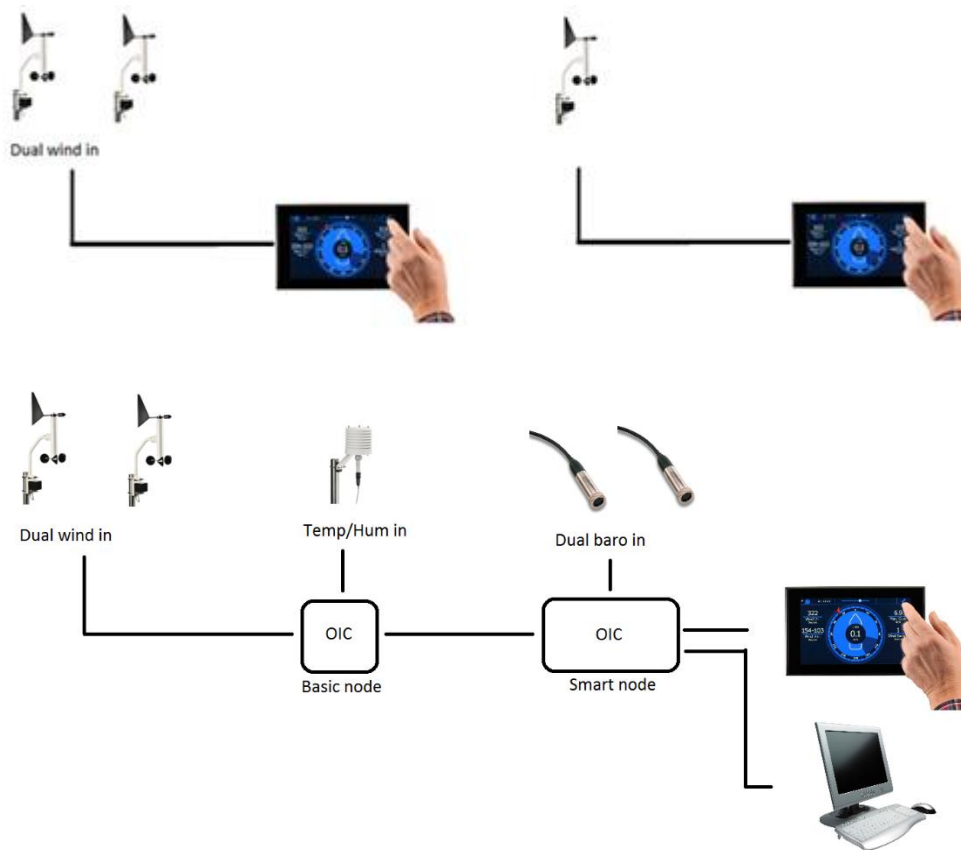

## 4 Installation

### 4.1 Unpacking

The scope of supply of the OMC-160 anemometer consists of a Styrofoam and cardboard box containing:

- sensor body with integral mounting arm
- cup unit
- vane unit
- U-bolts
- mounting materials
- this manual (on CD)

Note that additional materials that were simultaneously ordered for the same order might be packed in the OMC-160 box.

### 4.2 Location of the sensor

Ensure that the OMC-160 anemometer will be mounted on a location where the wind that is free from turbulence e.g. caused by obstacles nearby. Plan the OMC-160 anemometer in a free area as far as



practicable. For guidance on the best location refer to the WMO CIMO Guide <sup>2</sup>. The location must be accessible for yearly maintenance.

### 4.3 Site preparation

The OMC-160 anemometer bracket can be mounted on a vertical pipe end with an external diameter between 35-60 mm. The pipe end should stop within 30 mm above the mounting clamp. In the vertical plane there will be about 75 mm free space between the end of the pipe and the cup unit.

Make sure that the mast is properly fixed to withstand rugged wind forces. For calculation purposes: the wind-capturing surface of the OMC-160 anemometer is approx. 700 cm<sup>2</sup> (0.07 m<sup>2</sup>). The pipe end must be free of vibration.

The following tools are required for mechanical installation of the OMC-160 anemometer:

- wrench 10 mm for M6 capped nuts
- wrench 16 mm for M10 nuts on U-bolts
- compass and/or binocular telescope

### 4.4 Mounting / mechanical installation

First connect the mounting clamp to the mast / pipe end. The top of the mounting clamp must be mounted less than 30 mm under the end of the pipe to prevent the pipe end blocking the wind flow to the cup unit.

**Securely tighten the nuts on the U-bolts, preventing the nuts vibrate loose.**

### 4.5 Assembly of cup and vane

The wind-sensors are shipped with the wind vane and cups disconnected from their appropriate units. On the common unit, the upper spindle is for the wind direction sensor, and the lower spindle for the wind speed sensor. To prevent damaging the wind vane and cups, properly mount the sensor/bracket combination on the mast before fitting the wind vane and cup-unit whenever possible.

The shafts of the OMC-160 anemometer and the inside of the cup unit and vane unit are conical. This enables fastening of the capped nut without the shaft turning along.

The cup unit and the vane blade are made of light materials for optimum response to the wind. Both are balanced to provide accurate measurement and to prevent vibration. Take care not to damage the cup unit or the vane blade while mounting.

Place the vane unit and mounting materials on the upper shaft in the following sequence:

- 1) Vane unit
- 2) Plain washer
- 3) Capped nut

Place the cup unit and mounting materials on the lower shaft in the following sequence:

- 1) Cup unit
- 2) Spring washer
- 3) Capped nut

---

<sup>2</sup> *Guide to Meteorological Instruments and Methods of Observation, WMO No. 8, 6th Edition, World Meteorological Organisation, Geneva, Switzerland, ISBN 978-92-63-10008-5*



## 4.6 Electrical installation

### 4.6.1 Connections

The OMC-160 anemometer is provided with a junction box to connect the sensor to the field cabling. The junction box provides a M20 gland for the power & signal cable.

If the OMC-160-3 heating option is fitted, an additional M20 gland is provided for a separate cable for 24 V heater power supply.

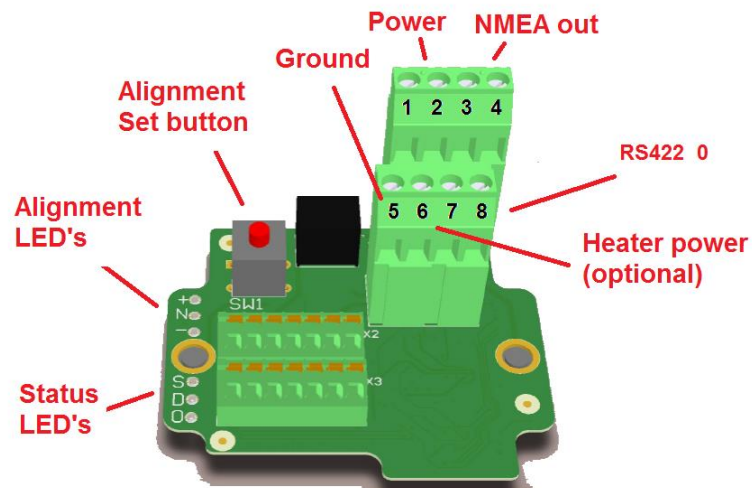

**Table 1: Connector X1**

Terminal	Function	Remarks
1	Power GND	
2	Power + 12-24VDC	60mA
3	NMEA output A / RS422 -	
4	NMEA output B / RS422 +	
5	Ground (connected to housing)	Shield connection NMEA out
6	Heater power, 24V (AC or DC) 2A	Optional
7	Heater power, 24V (AC or DC) 2A	Optional
8	RS422 0	Use only for RS422

Recommended cable: shielded 2x2x0.75mm<sup>2</sup> (like OMC-494)



**Terminal 5** must be used for NMEA shield connection.

**Terminal 8** is meant as 0 reference in case the receiver has a RS422 input, a separate wire should be used and connected to the signal ground of the receiver.

**Do not use terminal 8 for shield connection, this can cause an earth fault!**



### 4.6.2 Alignment LED's

Table 2: Upper LED's on junctionbox PCB

		On
+		Direction within 1 – 5 degrees
N		Direction is 0 degrees
-		Direction within 355 - 359 degrees

### 4.6.3 Status LED's

Table 3: Lower LED's on junctionbox PCB

		On	Off
S		Speed sensor OK	Speed sensor fault
D		Direction Sensor OK	Direction sensor fault
O		Flashes at NMEA output rate	No NMEA output

---

## 5 Commissioning

### 5.1 Commissioning procedure

- 1) Check the connections.
- 2) Install the interface and (if applicable) the display instrument. Normally the OMC-160 anemometer is powered through the interface unit.
- 3) Align the wind vane.

#### 5.1.1 Alignment of the wind vane

The wind direction sensor needs to be aligned:

- To North; usually for land based or fixed applications.
- To the bow; usually for shipborne installations.

**Procedure:**

- Sensor needs to be powered
- Vane needs to be tightened
- Open the junction box.
- Direct the vane exactly to North or the bow; whichever is applicable.
- Press the alignment button, after approx. 3s until the alignment LED's start flashing, release the button.
- Check alignment: when correct, the middle LED (N) should lit. Repeat procedure if a correction is required.
- Close the junction box and tighten carefully.

Note that the accuracy of the wind direction reading of the OMC-160 anemometer depends fully on the alignment of the vane!

It is impossible to calibrate the OMC-160 anemometer in the field. However, the following procedure makes sure that the installation was successful.

- 4) Check the direction readings. At various wind directions, make sure that the change in reading corresponds to the direction of the vane. For interpretation of the wind direction reading, remind that the wind direction is defined as the direction where the wind comes from. The readings should be reasonable.
- 5) Check the wind speed reading. Table 4 can be used for estimation of the actual wind speed. The reading should be reasonable.

**Table 4** Beaufort scale

Force [Bft]	Speed		Name	Conditions at sea	Conditions on land
	knots	m/s			
0	< 1	<0.2	Calm	Sea like a mirror.	Smoke rises vertically.
1	1-3	0.3-1.5	Light air	Ripples only.	Smoke drifts and leaves rustle.
2	4-6	1.6-3.3	Light breeze	Small wavelets (0.2 m). Crests have a glassy appearance.	Wind felt on face.
3	7-10	3.4-5.5	Gentle breeze	Large wavelets (0.6 m), crests begin to break.	Flags extended, leaves move.
4	11-16	5.5-7.9	Moderate breeze	Small waves (1 m), some whitecaps.	Dust and small branches move.
5	17-21	8.0-10.7	Fresh breeze	Moderate waves (1.8 m), many whitecaps.	Small trees begin to sway.
6	22-27	10.8-13.8	Strong breeze	Large waves (3 m), probably some spray.	Large branches move, wires whistle, umbrellas are difficult to control.
7	28-33	13.9-17.1	Near gale	Mounting sea (4 m) with foam blown in streaks downwind.	Whole trees in motion, inconvenience in walking.
8	34-40	17.2-20.7	Gale	Moderately high waves (5.5 m), crests break into spindrift.	Difficult to walk against wind. Twigs and small branches blown off trees.
9	41-47	20.8-24.4	Strong gale	High waves (7 m), dense foam, visibility affected.	Minor structural damage may occur (shingles blown off roofs).
10	48-55	24.5-28.4	Storm	Very high waves (9 m), heavy sea roll, visibility impaired. Surface generally white.	Trees uprooted, structural damage likely.
11	56-63	28.5-32.6	Violent storm	Exceptionally high waves (11 m), visibility poor.	Widespread damage to structures.
12	64+	>32.6	Hurricane	14 m waves, air filled with foam and spray, visibility bad.	Severe structural damage to buildings, wide spread devastation.

---

## 6 Maintenance

### 6.1 Maintenance schedule (preventive maintenance)

Initial maintenance interval is two year under normal circumstances. Maintenance is best planned in the season when outside work is most comfortable.

For critical applications (where wind data is of major importance) under severe conditions, an initial maintenance interval of 12 to even 6 months might be considered.

The maintenance interval can be adjusted depending on the maintenance experience.

Periodic maintenance comprises inspection on the following points:

- check ball bearings; replace if necessary
- check cabling and cable support
- check mounting; retighten if necessary
- clean the sensor if necessary

Refer to paragraph 6.5 for more information about the mechanical aspects. If the ball bearings require replacement, the OMC-160 anemometer must be removed from its location.

### 6.2 Removing the OMC-160 anemometer from its location

- 1) Disconnect the power supply tot the sensor (display / data collection unit or PSU).
- 2) Remove the vane unit and the cup unit.

The cup unit and the vane blade are made of light materials for optimum response to the wind. Both are balanced to provide accurate measurement and to prevent vibration.

**Take care not to damage the cup unit or the vane blade while mounting or disassembly.**

The shafts of the OMC-160 anemometer and the inner side of the cup unit and vane unit are conical. After removal of the capped nut and washer, it might require a careful tap to loosen the cup unit or vane unit from its shaft.

- 3) Disconnect the cable in the junction box.
- 4) Loose the U-bolts and remove the OMC-160 body from its location.

### 6.3 Recalibration

If the OMC-160 anemometer is included in a calibration program, the recommended calibration interval is 2 years. If required, you can adjust this interval.

Calibration of wind speed sensor is only possible in a wind tunnel. Observator Instruments B.V. provides calibration services. For address details see chapter 9. Always include the cup unit and the vane unit when the OMC-160 anemometer is shipped for recalibration.

## 6.4 Opening and closing the anemometer

The Observator OMC-160 anemometer is designed for low maintenance. The construction is entirely made of non-corrosive materials and all components are conservatively rated.

The only components that are likely to require replacement due to normal wear are the precision ball bearings. The OMC-160 anemometer must be opened to replace the bearings.

**The OMC-160 anemometer should only be opened or disassembled in a clean workshop**

**The OMC-160 anemometer should only be opened or disassembled by a qualified mechanical engineer**

Refer to the assembly drawings of the anemometer for part names and locations.

First remove the cup unit or vane unit from their body by unscrewing the capped nut and lifting the unit. Unscrew the bearing housing (2) or (3)

## 6.5 Replacement of ball bearings and sensor PCB's

First, open the sensor housing as described in section 0

To gain access to the bearings remove the bearing cover-plate. The bearings can now be taken out complete with the shaft.

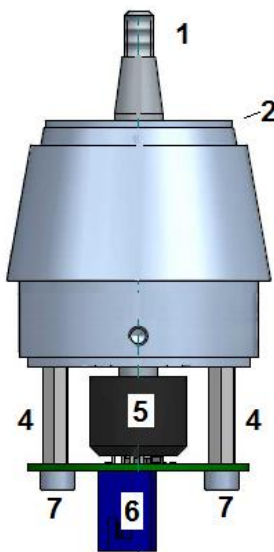

Direction head assembly

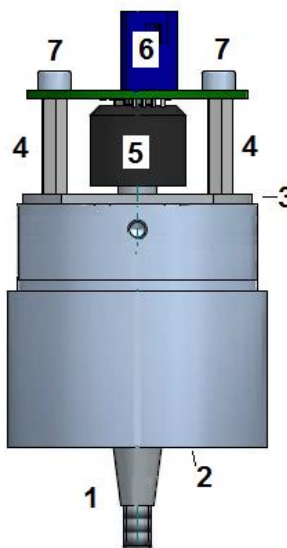

Speed head assembly

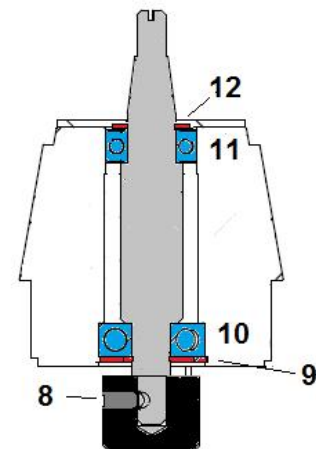

Shaft –bearing assembly  
(identical\* for both heads)

- |                                  |                              |
|----------------------------------|------------------------------|
| 1. Shaft                         | 8. Hex screw                 |
| 2. Bearing cover end plate       | 9. Circlip large*            |
| 3. Bearing cover (speed) plate** | 10. Bearing large            |
| 4. Columns                       | 11. Bearing small            |
| 5. Sensor element                | 12. Circlip small            |
| 6. Sensor PCB / Connector        | 13. Connector Cable assembly |
| 7. Hex bolts                     | 14. Ground wire              |

\* Circlip (9) only present when no bearing cover (4) is fitted

\*\* Bearing cover plate is replaced by Circlip 9 in some speed heads and all direction heads.



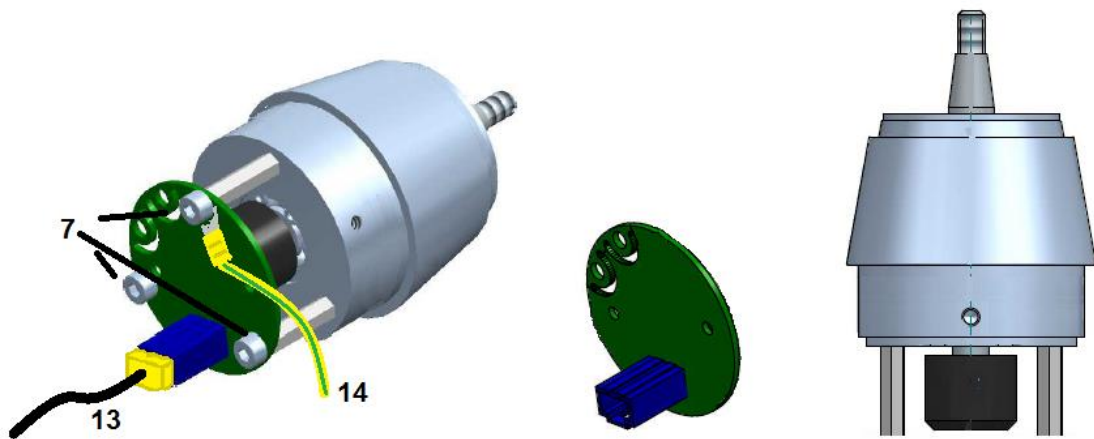

### Sensor PCB (6) removal

Identical for both speed and direction head:

1. Take the cable connector (13) out of the PCB connector of the sensor PCB.
2. Remove the 3 hex bolts (7), this will also release the ground wire (14).

### Bearing removal

Identical for both speed and direction head unless otherwise specified:

1. First remove PCB (see Sensor PCB (6) removal)
2. Remove the 3 columns (4)
3. Loosen the sensor element hex screw (8)
4. Remove the sensor element (5)
5. Remove the bearing cover plate (3) (Speed head only if applicable)
6. Remove the large circlip (9)
7. Loosen the 2 screws of the bearing cover end plate (2) and remove the plate
8. Carefully tap out the bearing assembly from the outside in using a suitable driver (dia 18mm+/-0.5) and hammer or press.
9. Remove small circlip
10. Use a pulley or press to remove bearings from shaft.

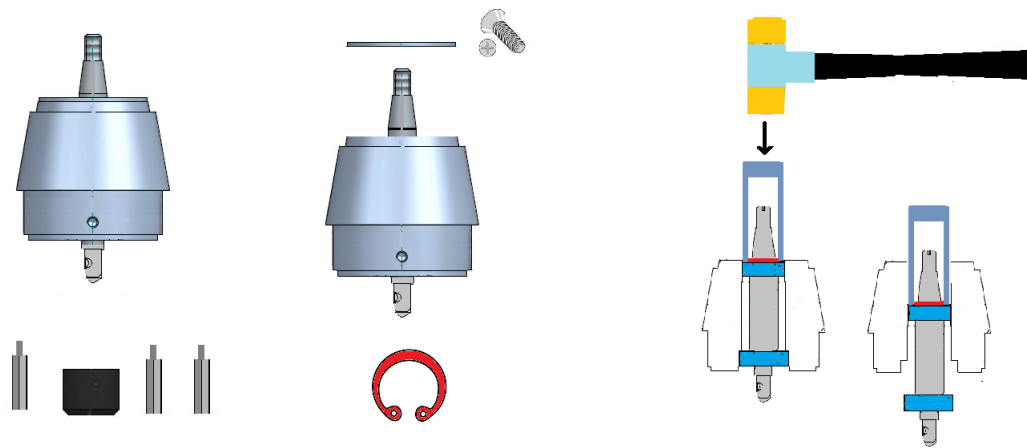

When the bearings are renewed, care should be taken not to apply excessive force on the new bearings. When re-installing the complete bearing housing with the sensor PCB's, care should be taken that the internal wiring is properly attached, and not touching any moving part.

## 7 Data protocol

### 7.1 General

The output of the OMC-160-3 is NMEA-0183 according IEC 61162-1.

### 7.2 Baudrate

The default baudrate is 4800 baud, 9600 baud can be set via the setup menu.

### 7.3 Messages

The OMC-160-3 NMEA-0183 output has the following messages:

**\$WIMWV,1,1,R,5.0,N,A\*hh<CR><LF>**  
           1 2 3 4 5

1. Wind angle, 0 to 359 degrees
2. Reference:
  - R = Relative
  - T = Theoretical
 Always R(egative) for OMC-160-3
3. Wind speed
4. Wind speed units: K/M/N/S (always M = Meter / second for OMC-160-3)
5. Status, A = Data Valid, V = Data invalid

**\$WIVER,1,1,WI,OBS,c--c,c--c,c--c,c--c,c--c,x\*hh<CR><LF>**  
           1 2 3 4 5 6 7 8 9 10

1. Total number of sentences needed, 1 to 9 (1)
2. Sentence number, 1 to 9 (1)
3. Device type (WI)
4. Vendor ID (OBS)
5. Unique Identifier (n/a, blank)
- 6. Manufacturer serial number (actual serial number of the unit)**
7. Model code (OMC-160-3)
- 8. Software revision (actual firmware revision id of the unit)**
9. Hardware revision (n/a, blank)
10. Sequential message identifier (0)

All parameters except 6 & 8 will be identical for each OMC-160-3 wind sensor.  
 Parameter 6 will be unique for each unit (Serial number)

#### Example Strings

```
$WIMWV,90.0,R,5.0,N,A*1F
$WIMWV,90.0,R,17.0,N,A*2C
```

```
$WIVER,1,1,WI,OBS,,160300008,OMC-160-3,00.08B00,,0*02
```

## 8 Specifications

### 8.1 Specifications

Parameter	Value
Type of instrument	Anemometer
Measuring principle	Cup and vane
Measuring system	ISO – Metric
Materials of exposed parts	Stainless steel
Material of cups	Polycarbonate
Ingress Protection	IP-65 according to EN-60529
Operation Temperature	-25 ... +70 deg. C
Humidity	5 ... 90%
Measuring range (wind speed)	0 ... 75 m/s
Accuracy (wind speed)	Better than 2 %
Threshold (speed)	Approx. 0.3 m/s
Distance constant	1.68 meters
Measuring range (wind direction)	0 ... 360 ° (no gap)
Direction accuracy (non-linearity etc.)	+/- 2 degrees
Output signal compatibility	NMEA 0183 v4.10 / IEC61162-1
Power sensor	12-24VDC, 60mA
Power heating (Optional)	24V (AC or DC), 2A
Overall height	Approx. 905 mm
Overall width (vane mounted)	Approx. 460 mm max.
Mounting method	Pole-mounting bracket with U-bolts (M10) for mounting on cylindrical or square pole
Clamping range	35 to 65 mm
Weight	Approx. 5 kgs. excluding cable
Packing dimensions	1050 x 510 x 150 mm
Packing weight	10 kgs.

## 9 Support, service and warranty

Support, service, and warranty on Observator Instruments equipment are provided by the company where the product was purchased. Make sure that you have the following information available when contacting

- Type and model of equipment
- Serial number
- Original order number and year of purchase

If it is impossible to find out where the instrument was purchased, please contact the manufacturer:

Observator Instruments B.V.  
PO Box 60  
2980 AB Ridderkerk  
The Netherlands  
Tel. + 31 180 463 411  
Fax + 31 180 463 530

Purchase of spare parts or replacements:

e-mail adres : [sales@observator.com](mailto:sales@observator.com)

Technical support, Service and warranty:

e-mail adres : [service@observator.com](mailto:service@observator.com)

## **10 Handling, transportation and storage**

### **10.1 Handling**

Keep the instrument in the protective Styrofoam package until installation. Care should be taken not to damage the cup unit the vane unit. Take care that the small mounting materials will not be lost.

Once the installed, store the packing for later use (see section 10.3)

### **10.2 Long term storage**

When not in use, store the OMC-160 anemometer in a dry place. Note that this is required, as the system is only weatherproof when mounted in an upright position.

### **10.3 Reshipping the instrument**

Whenever the OMC-160-3 anemometer is shipped, e.g. for calibration or repair, it should be shipped in the original Styrofoam packing. If this is no longer available on site, replacement packing can be ordered from Observator Instruments or one of their world-wide agents or resellers. For contact information please refer to section 9.

If the anemometer is shipped for calibration, please also include the vane unit and cup units, as those parts are required during calibration.

## 11 Advanced configuration

Function	Default	Option
Baud rate	: 4800	9600
Output Interval	: 4 Hz	1 Hz
NMEA Identifier	: WI	2 Characters (A..Z) free selectable
NMEA VER Sentence	: Enabled	off
Speed Linearization	: Enabled	off

Changing these settings requires a RS485 (half duplex = 2 wire) connection (RS485 to USB converter), PC and a terminal program. Any basic terminal program will do, you can download a free terminal program 'OMC-Terminal' from our website:

<https://observator.com/en/support/software>

Connect to the NMEA output of the sensor (terminal 3 & 4) and setup the terminal (4800\*,8,n,1).

Power cycle the sensor and press [ESC] within 5s.

The main menu should appear:

```

=====
=   OMC-160-3 Main Menu   =
=====
=   Version 00.90 B006   =
=====

1 Serial          : 160399999
2 Baudrate        : 4800
3 Output Interval : 4 Hz
4 NMEA Identifier : WI
5 NMEA VER Sentence : Enabled
6 Speed Linearization : Enabled
7 North Offset    : 215

0 Exit Menu
1 - 7 Change Setting
  
```

Settings can be changed with the corresponding numbers.

We advise to keep speed linearization enabled unless you compensate the sensor otherwise. North Offset will be overwritten during the alignment procedure (with the pushbutton).

*\*if output was set to 9600, use 9600 here as well.*

## 12 Dimensional Drawing

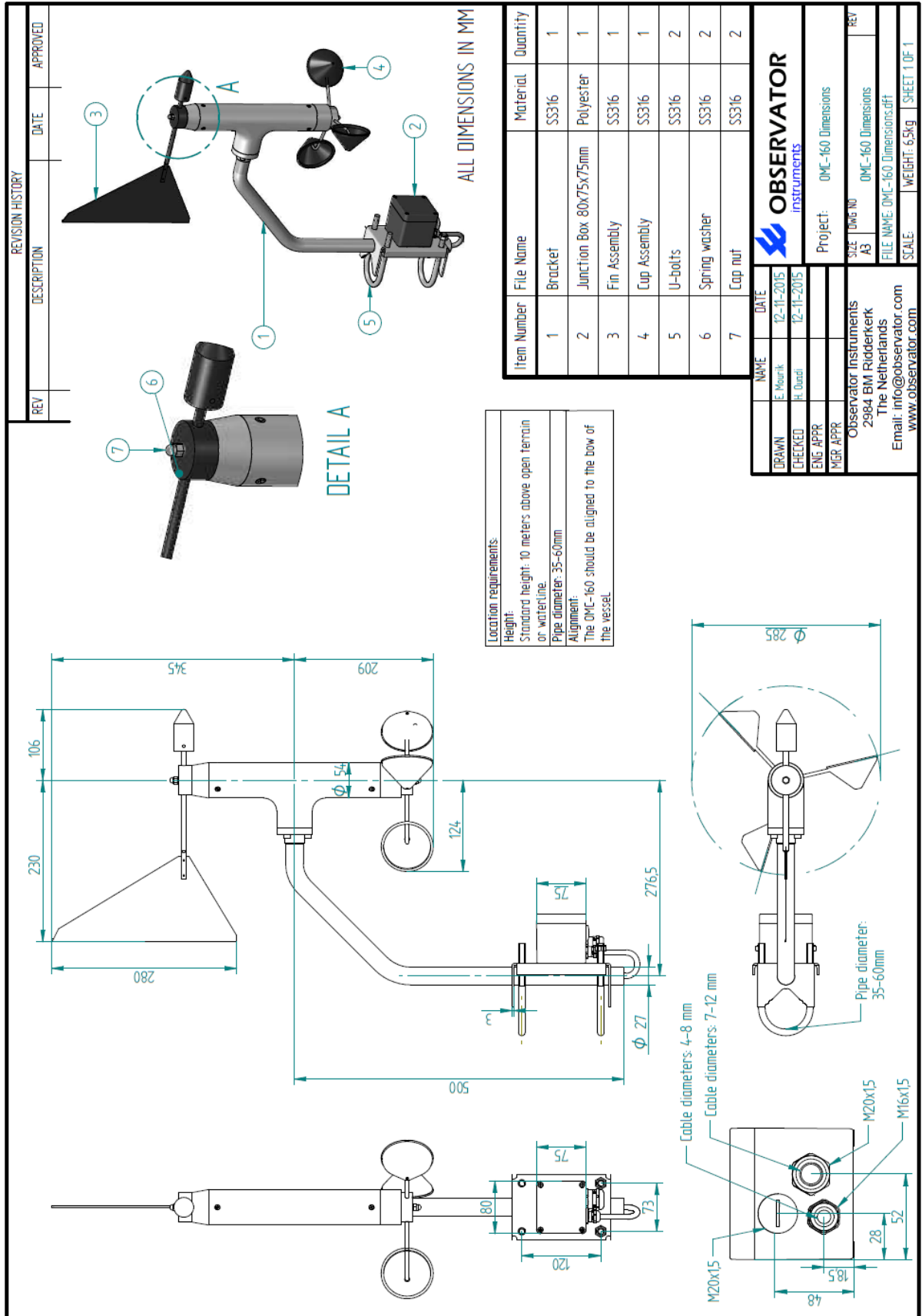



## 13 EU Declaration of Conformity



Observator Instruments B.V.

Rietdekkerstraat 6  
2984 BM Ridderkerk  
The Netherlands

Tel: +31 (0)180 463411  
Fax: +31 (0)180 463530

Email: [info@observator.com](mailto:info@observator.com)  
Internet: [www.observator.com](http://www.observator.com)  
CoC: 24172722

### EU DECLARATION OF CONFORMITY

(1) Apparatus model: **OMC-160-3**

(2) Manufacturer:  
**Observator Instruments B.V.**  
**Rietdekkerstraat 6**  
**2984 BM Ridderkerk**  
**The Netherlands**

(3) This declaration of conformity is issued under the sole responsibility of the manufacturer.

(4) Object of the declaration:

**OMC-160-3 Wind Sensor**  
**Including all manufacturer-supplied options for these products**

(5) The object of the declaration described above is in conformity with the relevant Union harmonisation legislation:

- Directive 2014/30/EU of the European Parliament and of the Council of 26 February 2014 on the harmonisation of the laws of the Member States relating to electromagnetic compatibility
- Directive 2014/35/EU of the European Parliament and of the Council of 26 February 2014 the harmonisation of the laws of the Member States relating to the making available on the market of electrical equipment designed for use within certain voltage limits
- Directive 2011/65/EU of the European Parliament and of the Council of 8 June 2011 on the restriction of the use of certain hazardous substances in electrical and electronic equipment

(6) References to the relevant harmonised standards used:

EN IEC 60945:2002 including EN IEC 60945/C1:2008  
EN IEC 61326-1:2013  
EN IEC 63000:2018

(7)

(8) Ridderkerk, 11-04- 2024,  
Observator Instruments B.V.

dr. R. de Vries  
CEO

