



B. HEPWORTH
AND COMPANY LIMITED

*...performance wiper
systems...*

INSTALLATION AND MAINTENANCE
INSTRUCTIONS FOR THE
50NM COMPACT
SINGLE STATION
WINDSCREEN WIPER SYSTEM

CONTENTS

CONTENTS	2
GENERAL INFORMATION AND SAFETY SUMMARY	3
Safety Precautions.....	3
Introduction.....	3
Vari-Arc Lever Settings	3
CHAPTER 1.....	4
Functional and Equipment Description of System.....	4
Wiper Motor Assembly	4
Exploded View of Linkage	4
Exploded View of Linkage	5
Electrical Connections	5
Wiper Arm Assembly - Pantograph.....	6
Wiper Arm Assembly - Pendulum.....	6
Wiper Arm Assembly - Pendulum.....	7
CHAPTER 2.....	8
Installation Instructions	8
Drilling Diagram.....	8
Fitting the Wiper Motor Assembly	8
Vari Arc Units - Arc adjustment.....	9
Electrical Connections	9
Wiring the Power Supply Unit (PSU).....	10
Wiring to a Multi Speed Control Switch	11
Wiring to a Toggle Switch.....	11
Wiring to a Rotary Switch	12
Fitting the Wiper Blade.....	12
Fitting the Wiper Arm Assembly – Both Arms	13
CHAPTER 3.....	14
Maintenance	14
Introduction.....	14
Safety Precautions.....	14
Scheduled Maintenance Action Check	14
Table 1	15
CHAPTER 4.....	15
Troubleshooting	15
Introduction.....	15
Safety Precautions.....	16
Troubleshooting Procedures	16
Table 2	16
Table 2 - Continued	17
CHAPTER 5.....	18
Maintenance Instructions	18
To Replace the Wiper Blade	18
To Replace the Wiper Arm.....	18
To Replace the 24v Drive Crank/Double Bearing Assembly	19
To Replace the 12v Drive Crank/Double Bearing Assembly	20
To Replace the Lever/Liner/Spindle Sub Assembly.....	21
Vari Arc Units - Arc adjustment.....	22
CHAPTER 6.....	22
Operation Instructions	22
Switch Operation – Multi-Switch	22
Switch Operation – Toggle Switch	23
Switch Operation – Rotary Switch	23
SPARES LIST	23

GENERAL INFORMATION AND SAFETY SUMMARY

As we will have no influence on the installation of complete windscreen wiper systems if installation is to be carried out by the customer, we are unable to accept liability for installation errors.

If you require any additional information or any special problems arise which the installation/maintenance instructions do not treat in sufficient detail please contact B. Hepworth and Co Ltd directly.

Safety Precautions

CAUTION! BEWARE OF INJURY!

BEFORE WORKING ON THE WIPER SYSTEM, OBSERVE THE FOLLOWING REMARKS WITHOUT FAIL!

Most wiper motors have a park setting, which permits them to default to the parked position if connected to the vehicle electrical system, even when the wiper is switched off. **FOR THIS REASON, AT THIS POINT IN TIME, NEITHER MAY THE WIPER ARM BE MOUNTED, NOR MAY ANY PERSON HAVE HANDS, FINGERS, ETC ANYWHERE NEAR THE WIPER SYSTEM.** Even small wiper motors can neither be braked nor stopped by hand.

NEVER REACH INTO THE AREA OF THE ROD LINKAGE WHEN THE SYSTEM IS RUNNING!

When putting into service (i.e. when connecting the wiper motor to the vehicle electrical system, even if the wiper switch is in the 0 position), never leave any loose items such as screwdrivers in the area of the wiper system, as flying objects could lead to injury.

Please ensure the equipment is handled with care. Do not drop or bang the equipment down on a hard surface taking extra care around the area where the motor shaft is situated. Do not hammer the motor shaft when installing the equipment, as this will cause the motor gear plate to deform causing premature failure of the unit.

Introduction

The Windscreen Wiper system utilised is detailed on the following pages. The primary components that form the Windscreen Wiper System are the wiper motor linkage, the wiper arm assemblies and wiper blades.

Vari-Arc Lever Settings

IMPORTANT

Vari-arc levers which have been factory set will be torqued and paint marked. Do not adjust. Unpainted lever nuts must be torque tightened M8 = 20Nm, prior to the unit being fitted.

CHAPTER 1

Functional and Equipment Description of System

Wiper Motor Assembly

The wiper motor and bracket is shown in Figures 1 & 2. The electric wiper motor forms the central part of the windshield wiper system. The motor is mounted on a fabricated mild steel bracket which is polyester powder coated to prevent corrosion. The motor is connected electrically by means of a multi-pin connector. (Ref Figure 3.)

The drive lever is secured to the wiper motor shaft and connected through a tie bar, to the spindle lever assembly. These components transfer the motor shaft rotation to the wiper arm assemblies.

The drive mechanism provided transfers the rotary output from the motor; to a reciprocating motion of the spindles, this mechanism is zinc plated and is sized to give the correct angle of arc for the windscreen wiper arm being driven.

The Spindles that drive the wiper arms pass through the bulkhead, connecting the drive mechanism to the wiper arm; these are manufactured from stainless steel, to prevent corrosion. The spindles are driven from the main drive crank by connecting tie bars which distributes the load evenly between the arms of the wiper arm thus reduces the load on the individual interfaces between the wiper arm and the spindles.

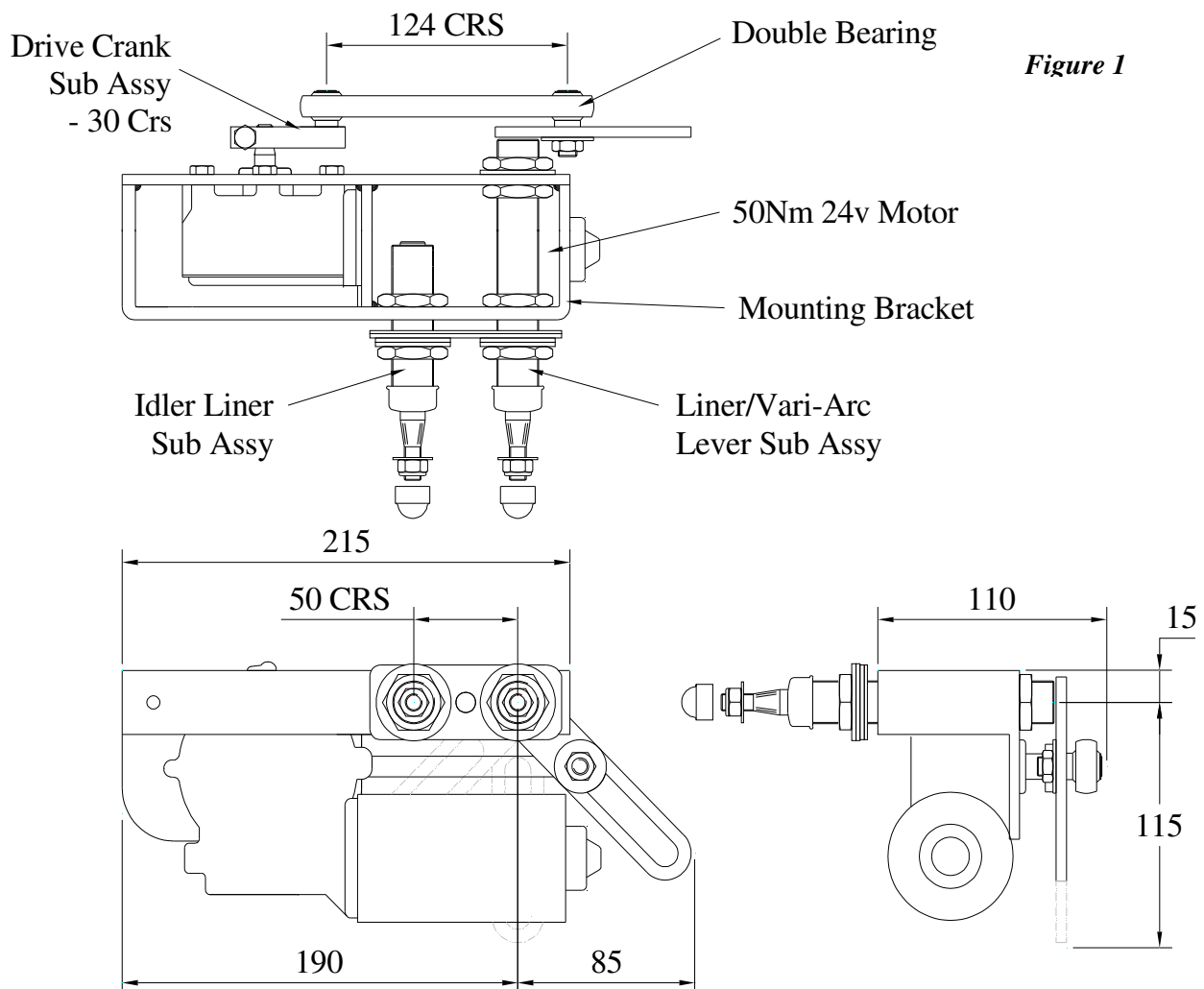
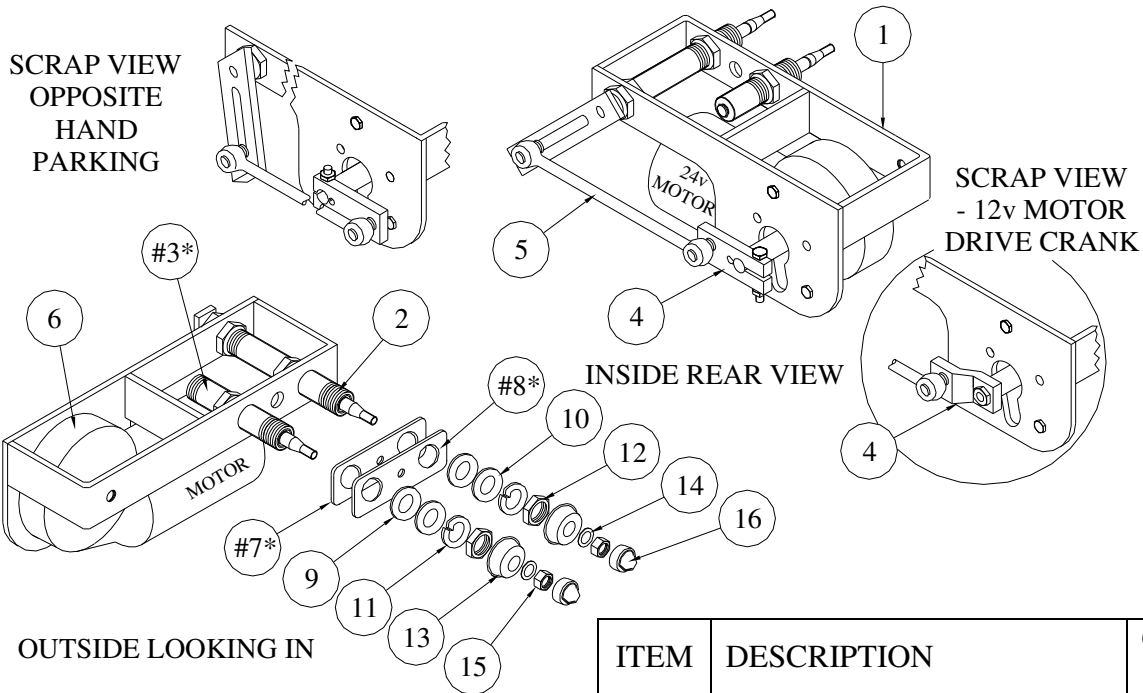

Figure 1

Exploded View of Linkage

Figure 2



ITEM	DESCRIPTION	QTY
1	Motor Mounting Bracket	1
2	Liner V.Arc Lever Sub Assy	1
#3*	Idler Liner Sub Assy (Panto Only)	1
4	Drive Crank Sub Assy 30 Crs	1
5	Double Bearing - 124 Crs	1
6	50Nm (IER) Motor	1

ITEM	DESCRIPTION	QTY PANTO	QTY PEND
#7*	Idler Gasket (Panto Only)	1	--
#8*	Idler Plate (Panto Only)	1	--
9	20mm Washer - Neoprene	2	1
10	20mm Washer - Flat	2	1
11	20mm Washer - Single Coil	2	1
12	M20 Hex. Nut	2	1
13	20mm Weather Cap	2	1
14	8mm Washer - Flat	2	1
15	M8 Nylock Nut	2	1
16	8mm Nut Weather Cap	2	1

Electrical Connections

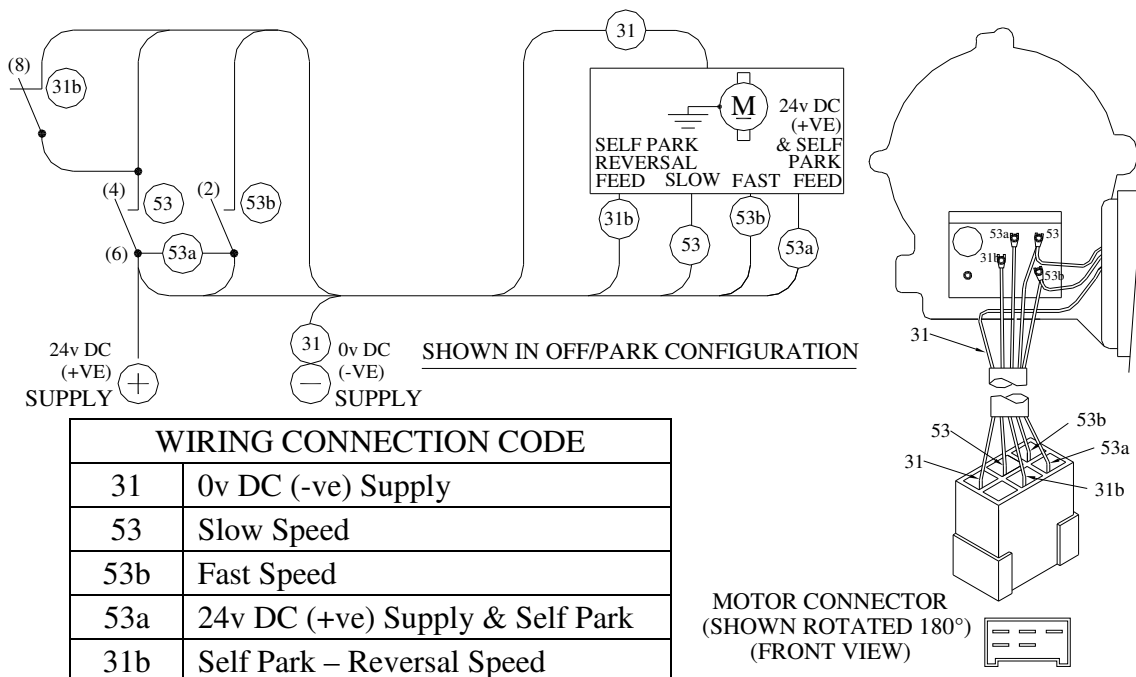

Wiper Arm Assembly - Pantograph

The wiper arm is manufactured from stainless steel and is polyester powder coated to prevent corrosion and to be of good appearance.

The wiper arm is shown in Figure 4 - Pantograph. One wiper arm assembly is used on each unit. The wiper arm assembly mounts directly onto the spindles protruding through the bulkhead. The wiper arm is secured to the spindles via a series of nuts and washers.

Note: In some cases the Arm may have a forward crank to aid wiping.

The blade is secured to the arm assembly using the blade clip arrangement on the arm and blade bolt.

Figure 4 - Pantograph

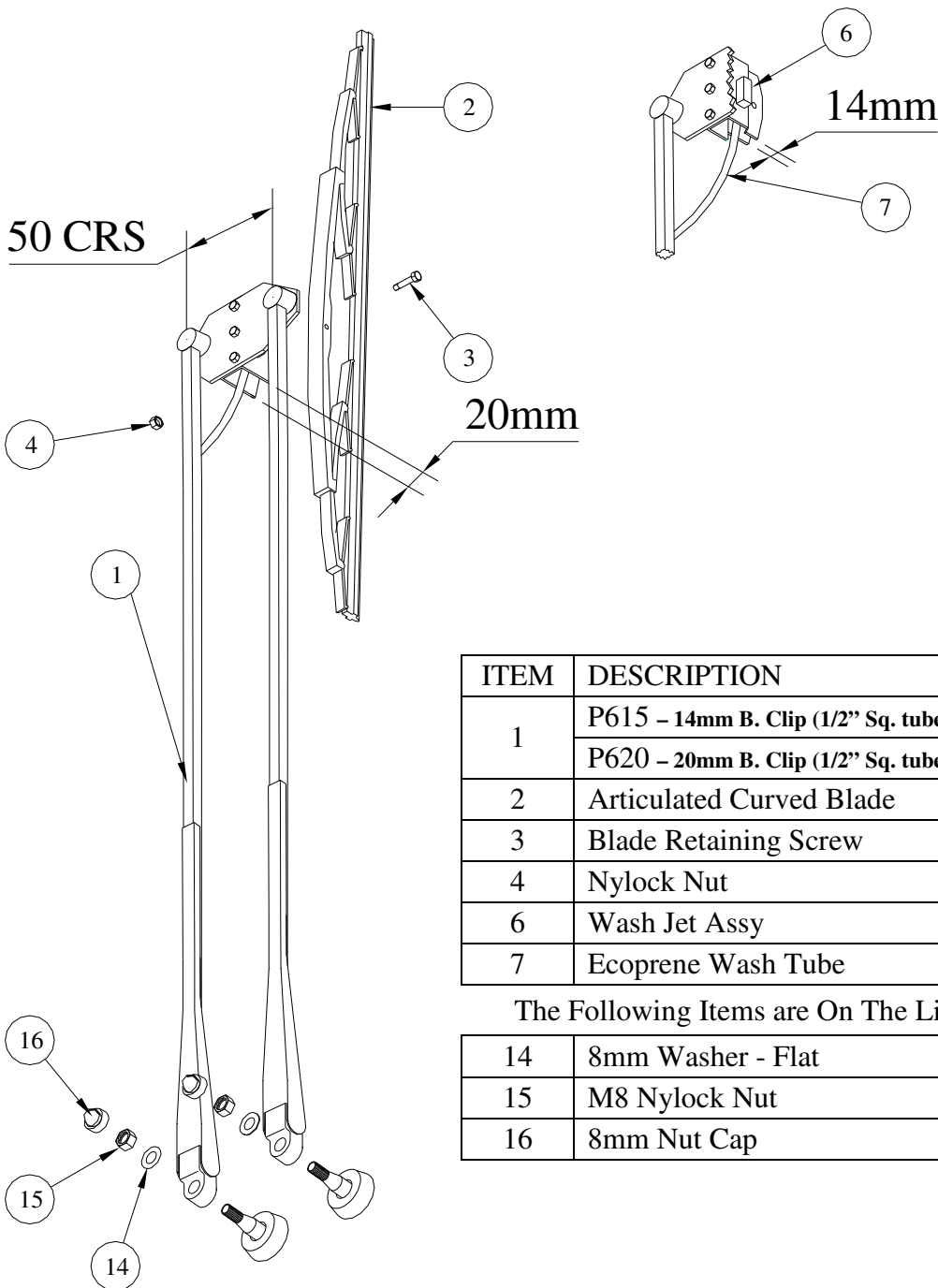

ITEM	DESCRIPTION	QTY
1	P615 – 14mm B. Clip (1/2” Sq. tube)	1
	P620 – 20mm B. Clip (1/2” Sq. tube)	1
2	Articulated Curved Blade	1
3	Blade Retaining Screw	1
4	Nylock Nut	1
6	Wash Jet Assy	1
7	Ecoprene Wash Tube	Metres

The Following Items are On The Linkage

14	8mm Washer - Flat	2
15	M8 Nylock Nut	2
16	8mm Nut Cap	2

Wiper Arm Assembly - Pendulum

The wiper arm is manufactured from stainless steel and is polyester powder coated to prevent corrosion and to be of good appearance.

The wiper arm is shown in Figure 4 –Pendulum. One wiper arm assembly is used on each unit. The wiper arm assembly mounts directly onto the spindle protruding through the bulkhead. The wiper arm is secured to the spindle via a series of nuts and washers.

Note: In some cases the Arm may have a sideways crank to aid wiping (see details below.)

The blade is secured to the arm assembly using the blade clip arrangement on the arm and blade retaining screw and nut.

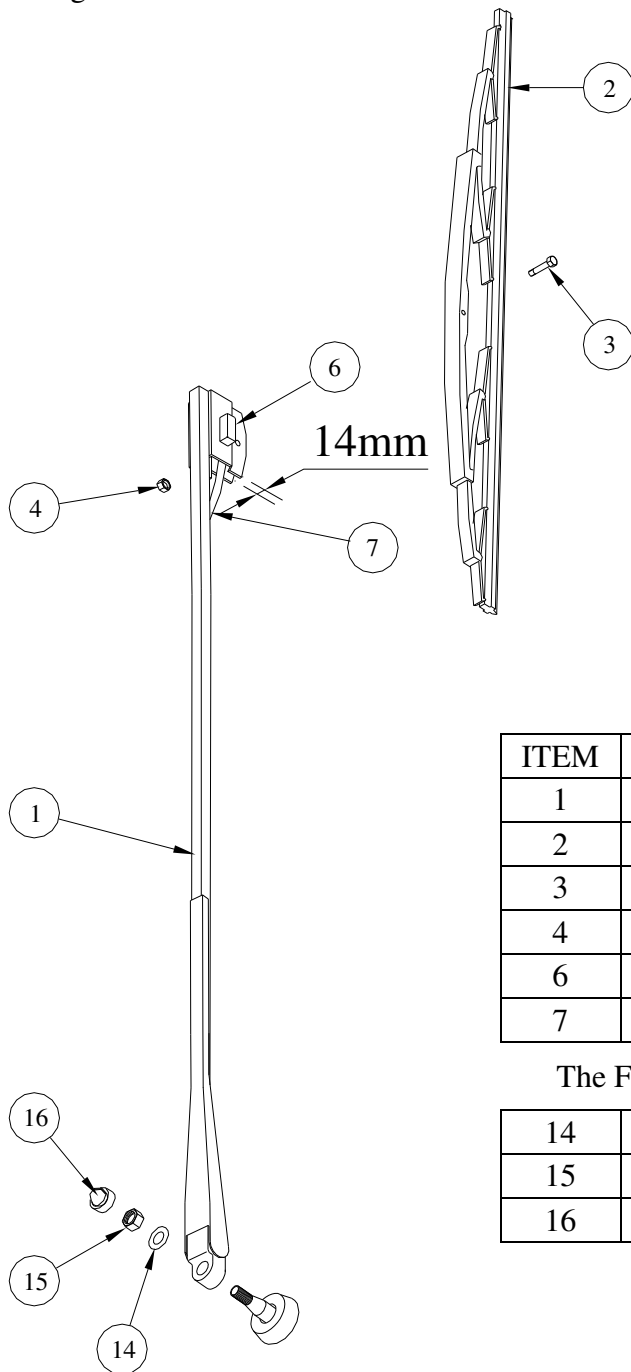

Figure 4 - Pendulum

ITEM	DESCRIPTION	QTY
1	F75 – 14mm B. Clip (1/2” Sq. tube)	1
2	Articulated Curved Blade	1
3	Blade Retaining Screw	1
4	Nylock Nut	1
6	Wash Jet Assy	1
7	Ecoprene Wash Tube	Metres

The Following Items are On The Linkage

14	8mm Washer - Flat	1
15	M8 Nylock Nut	1
16	8mm Nut Weather Cap	1

CHAPTER 2

Installation Instructions

These instructions are meant as a guide. If you experience any difficulty in the fitting of these units, please do not hesitate to contact us for advice.

Drilling Diagram

NOTE - Drilling Diagram is NOT to size and is for reference only

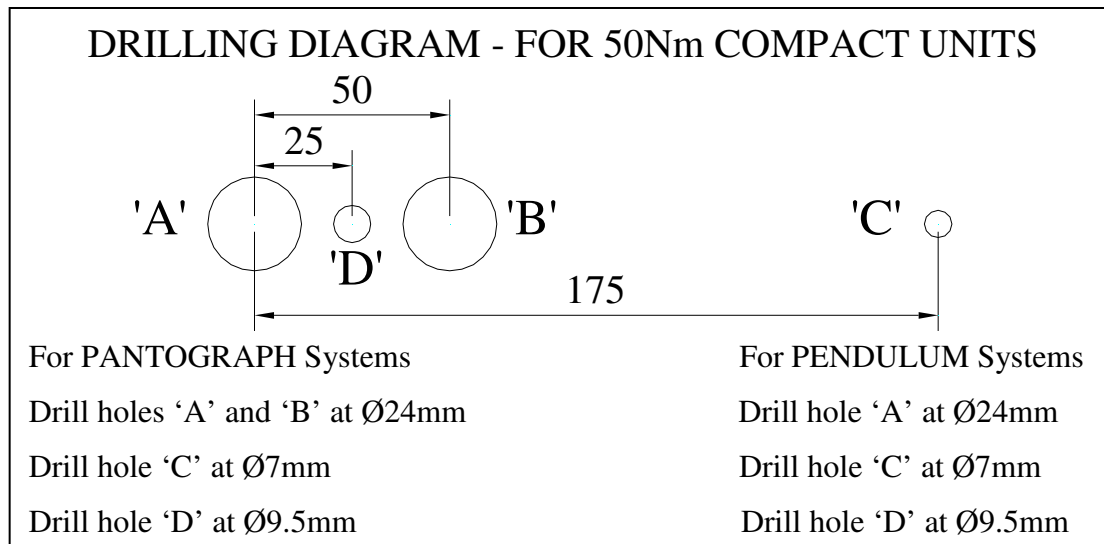

Fitting the Wiper Motor Assembly

IMPORTANT

Vari-arc levers which have been factory set will be torqued and paint marked. Do not adjust. Unpainted lever nuts must be torque tightened M8 = 20Nm, prior to the unit being fitted.

When the spindle positions have been drilled in the bulkhead, the following procedures apply.

1. Remove Weather Caps - (*Item 16*), M8 Nuts - (*Item 15*), Flat Steel Washers - (*Item 14*), Weather Caps - (*Item 13*), M20 Nuts - (*Item 12*), Single Coil Washers - (*Item 11*), Flat Steel Washers - (*Item 10*), and Neoprene Washers - (*Item 9*).
2. On Pantograph units only – Also remove Idler Plate - (*Item 8*) and finally Idler Gasket - (*Item 7*). NOTE: - Keep safe as will be required on assembly.

NOTE the Motor Unit is MOUNTED from INSIDE the Bulkhead.

3. Fit Motor Unit and fix in place through predrilled mounting holes (Fixing bolts not supplied)
4. *Externally* - ENSURE a proprietary sealant (Not supplied) is used around all points of entry through bulkhead.
5. *Fit following items* - On Pantograph units only Idler Gasket - (*Item 7*) and Idler Plate - (*Item 8*) over both Liners, next to bulkhead.
6. Onto each Liner a Neoprene Washer - (*Item 9*), a Flat Steel Washer - (*Item 10*), a Single Coil Washer - (*Item 11*), a M20 Nut - (*Item 12*) and finally a Weather Cap - (*Item 13*).
7. *Internally* - Connect vehicle wiring to Motor.

Vari Arc Units - Arc adjustment

IMPORTANT

Vari-arc levers which have been factory set will be torqued and paint marked. Do not adjust. Unpainted lever nuts must be torque tightened M8 = 20Nm, prior to the unit being fitted.

1. **Internally** - Run Motor to insure it is parked correctly. Disconnect all Electrical Power.
2. Slacken Securing Nylock Nut - (Item 26) on Vari Arc Lever.
3. Slide Double Bearing Pivot Pin - (Item 27) towards Liner/Spindle Assembly to INCREASE arc to 90° max or away from Liner/Spindle Assembly to DECREASE arc to 40° min.
4. Ensure you note markings on lever when correct arc is reached. Important: Pantograph Systems must not exceed 90° arc of wipe
5. Tighten Securing Nylock Nut - (Item 26) on Vari Arc Lever (Torque 20Nm)

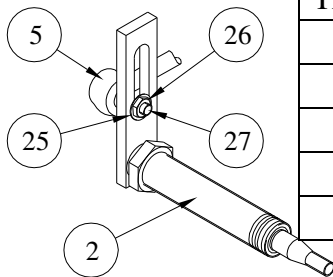
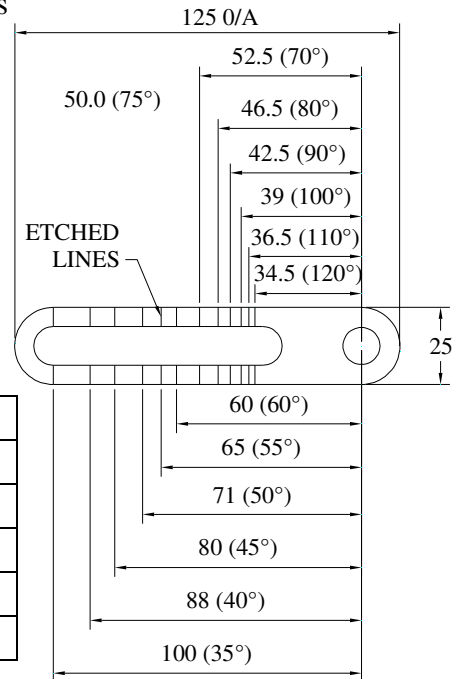

ITEM	DESCRIPTION	QTY
2	Liner V.Arc Lever Sub Assy	1
5	Double Bearing – 124 Crs	1
25	8mm Washer – Flat	1
26	M8 Securing Nylock Nut	1
27	V.Arc Bearing Pivot Pin	1

Electrical Connections

The 50Nm Marine Motor is available in either 12v or 24v DC, and are both, two speed self-parking motors with Insulated Earth Return as standard.

The motor should be connected through a two speed self-park multi speed control switch, a toggle switch or a rotary switch (not supplied – Can be ordered separately).

For Ships Supply's of nominal 110/120v AC 1 Phase – one of the following will be required

PSU/115/12/6 POWER SUPPLY UNIT-115v 12v 6amp will power 1-2 Motor Units
 PSU/115/12/12 POWER SUPPLY UNIT-115v 12v 12amp will power 3-4 Motor Units

PSU/115/24/6 POWER SUPPLY UNIT-115v 24v 6amp will power 1-2 Motor Units
 PSU/115/24/12 POWER SUPPLY UNIT-115v 24v 12amp will power 3-4 Motor Units

For Ships Supply's of nominal 220/240v AC 1 Phase – one of the following will be required

PSU/230/12/6 POWER SUPPLY UNIT-230v 12v 6amp will power 1-2 Motor Units
 PSU/230/12/12 POWER SUPPLY UNIT-230v 12v 12amp will power 3-4 Motor Units

PSU/230/24/6 POWER SUPPLY UNIT-230v 24v 6amp will power 1-2 Motor Units
 PSU/230/24/12 POWER SUPPLY UNIT-230v 24v 12amp will power 3-4 Motor Units

Wiring the Power Supply Unit (PSU)

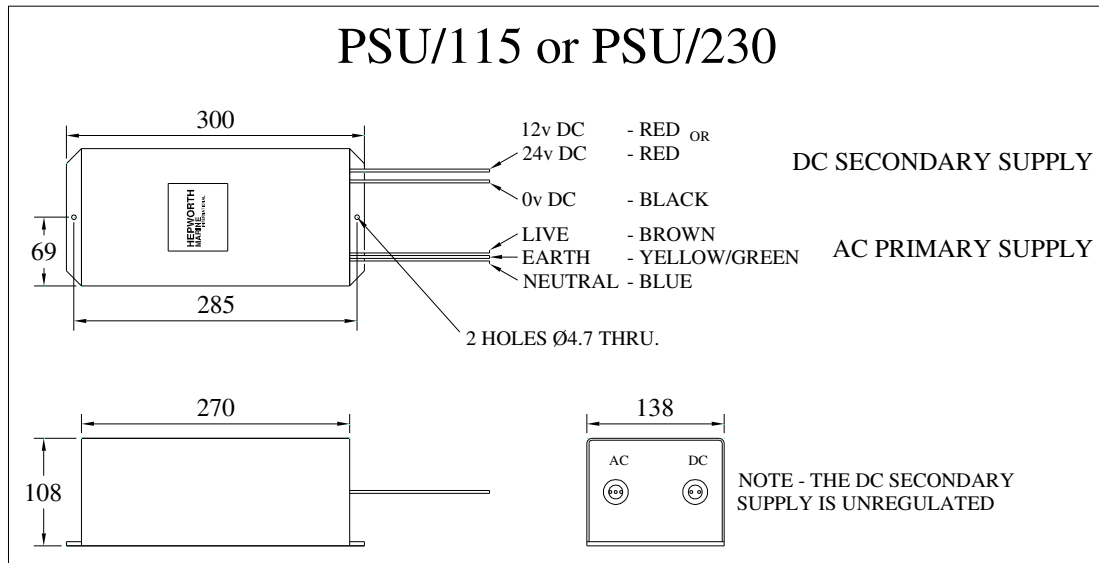

AC Primary Side

Connect the Live, Earth and Neutral wires on the AC Primary side of the Power Supply Unit to the Ships Supply -**110/120v AC** 1 Phase to a PSU/115 Unit, or **220/240v AC** 1 Phase to a PSU/230 Unit

DC Secondary Side

Connect the **12v** or **24v DC** (+ ve) to the Toggle, Rotary or Multi Speed Control Switch as the positive ship's supply

Connect the **0v DC** (- ve) to the Toggle, Rotary or Multi Speed Control Switch as the negative ship's supply

Wiring to a Multi Speed Control Switch

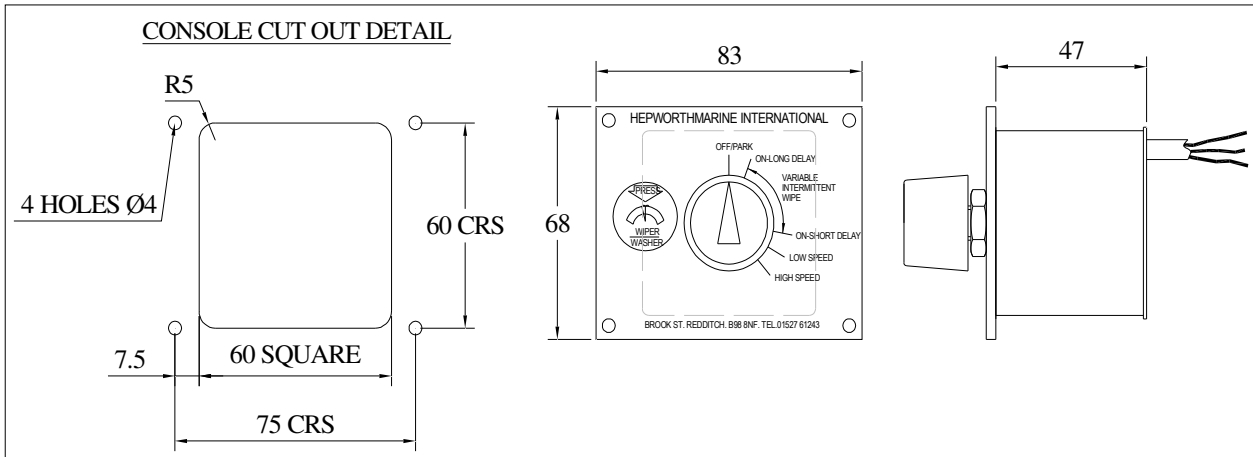

The RED wire on the switch	To terminal 53a on the motor - (SELF PARK FEED) and the positive ship's supply – 12v or 24v DC (+ ve)
The WHITE wire on the switch	To terminal 53b on the motor - (HIGH SPEED)
The YELLOW wire on the switch	To terminal 53 on the motor - (LOW SPEED)
The BLUE wire on the switch	To terminal 31b on the motor - (SELF PARK REVERSAL FEED)
The BLACK wire on the switch	To terminal 31 on the motor and the negative ship's supply – 0v DC (- ve)
The BROWN wire on the switch	To the Washer Pump (+ ve)

Wiring to a Toggle Switch

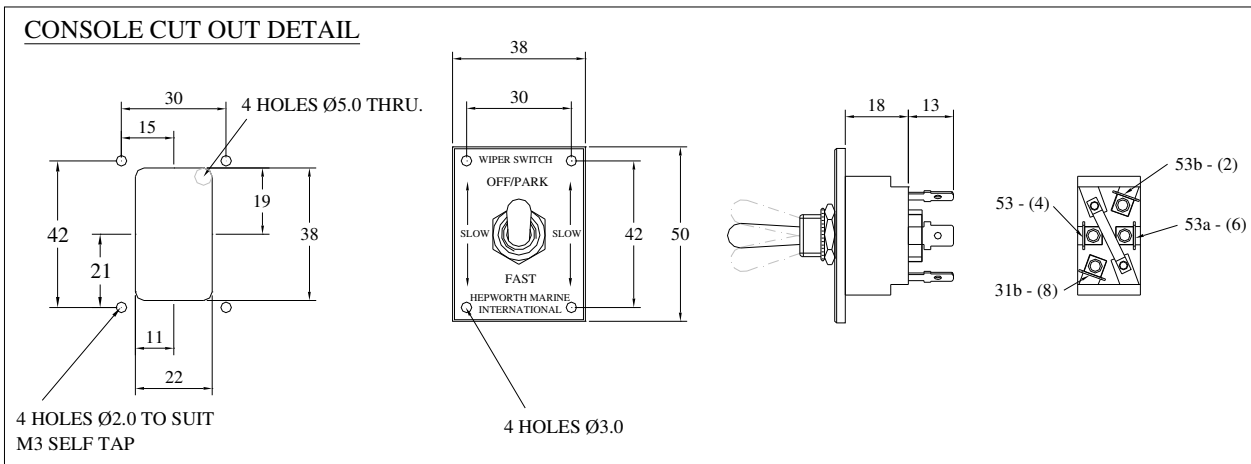

Position 8 on the switch	To terminal 31b on the motor (SELF PARK REVERSAL FEED)
Position 4 on the switch	To terminal 53 on the motor (LOW SPEED)
Position 6 on the switch	To terminal 53a on the motor (SELF PARK FEED) and the positive ship's supply – 12v or 24v DC (+ ve)
Position 2 on the switch	To terminal 53b on the motor (HIGH SPEED)
The negative ship's supply – 0v DC (- ve)	To terminal 31 on the motor

Wiring to a Rotary Switch

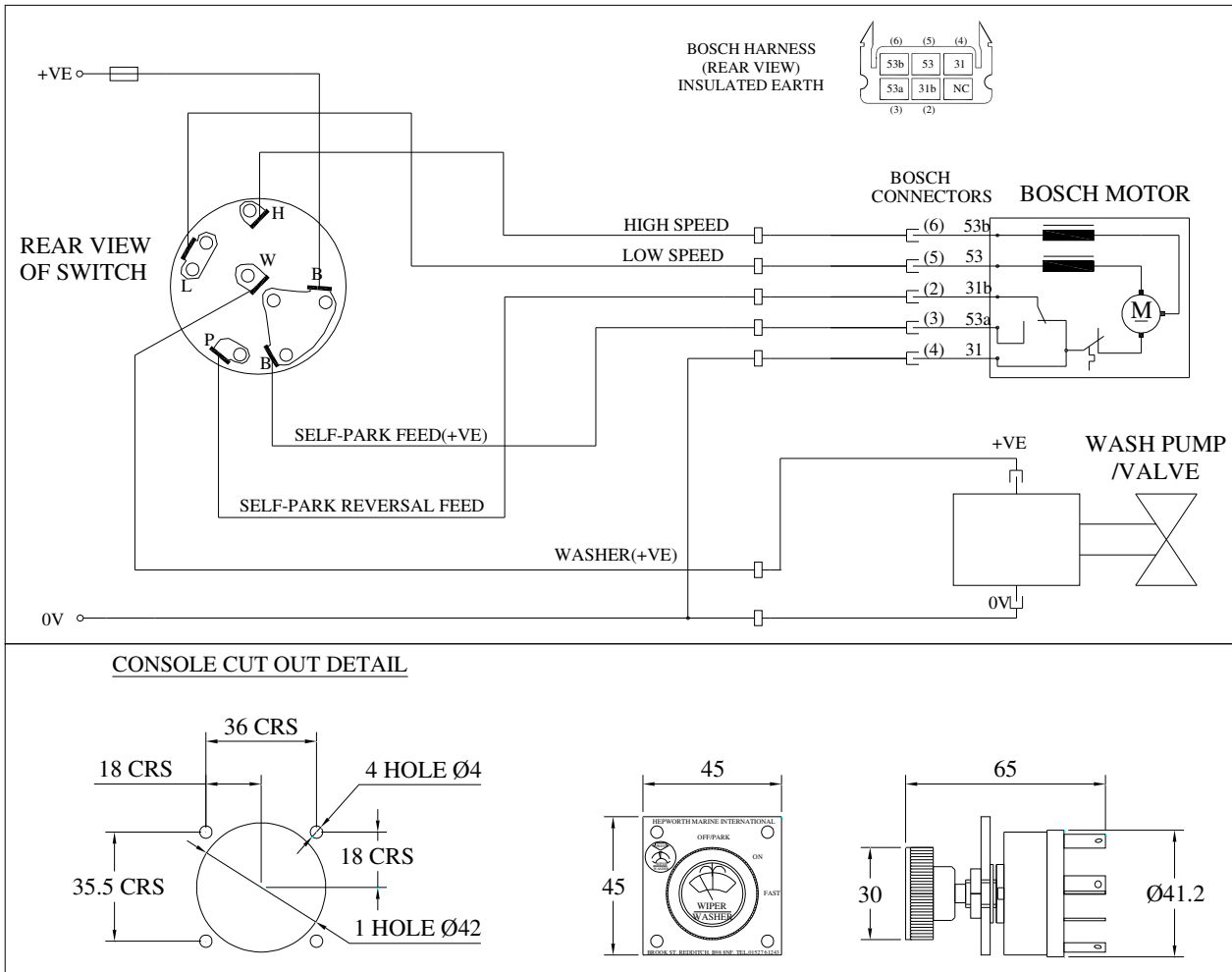

Fitting the Wiper Blade

With Reference to the Arm Drawings – Pages 6 & 7.

1. **Externally-** Remove Blade Retaining Screw - **(Item 3)** and Nut - **(Item 4)** from Blade Clip on Main Arm. - **(Item 1)**
2. Place Wiper Blade - **(Item 2)** into Blade Clip.
(Note If only one end of blade rubber captive, it must be at top of screen.)
3. Ensure that all fixing holes align. Secure in place with Blade Retaining Screw - **(Item 3)** and Nut - **(Item 4)**. Important DO NOT over tighten Blade Retaining Screw and Nut, as Blade is required to pivot on glass.

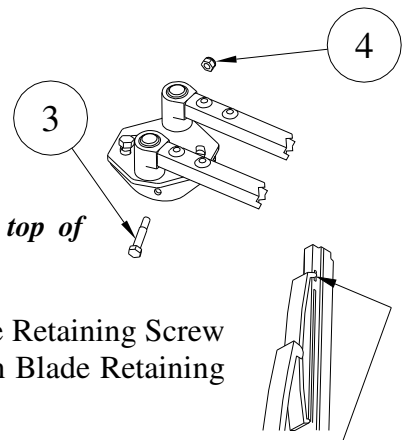

CAPTIVE CLIP TO BE AT THE TOP OF SCREEN

The wiper blades should be changed every 6 months but this is dependent on use and operating conditions.

(Wiper Blades - Ref Table1, Page 14 & Table 2 – continued, Page 16)

Fitting the Wiper Arm Assembly – Both Arms

With Reference to the Arm Drawings – Pages 6 & 7.

IMPORTANT

The Blade must be fitted to the Arm prior to the Arm being fitted. (This is to prevent the Blade Clip damaging the screen,)

1. **Internally** - Run Motor to insure it is parked correctly. Disconnect all Electrical Power.
2. **Externally**- While Unit is being run, it is IMPORTANT to observe direction drive spindle rotates in immediately before it stops. This direction will give PARK POSITION.

Pantograph Arms Only:

3. Fit Arm onto Spindle allowing Blade to lie approx 50-75mm from edge of glass in PARKED POSITION.
4. Fit a M8 Flat Washer - (Item 14) on to spindle next to Arm Head, then a M8 Nylock Nut - (Item 15)
5. Only tighten Nut sufficiently to allow Arm and Blade to travel across glass when Motor is run to see if positioning is correct.
6. If incorrectly positioned - DO NOT ATTEMPT TO ROTATE OR TWIST ARM ON SPINDLE this will damage splined end of drive spindle, resulting in Arm and Blade slipping in operation.
7. To correct alignment errors, - loosen Nut and gently pull Arm up Spindle, realign and repeat stages above.
(Arm Extractor Tool is available see Page 13 for instructions)
8. When correctly aligned, tighten M8 Spindle Nut 20Nm. Then fit Weather Cap supplied with Linkage - (Item 16)

IMPORTANT

On first fitting, check spring pressure on blade in parked position, it must NOT exceed recommended pressure. If this happens contact B. Hepworth. For details see Chapter 4, Table 2 – Continued, Page 16.

OPERATING THE EXTRACTOR

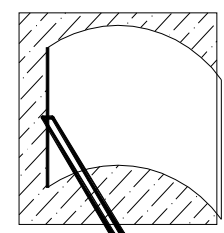
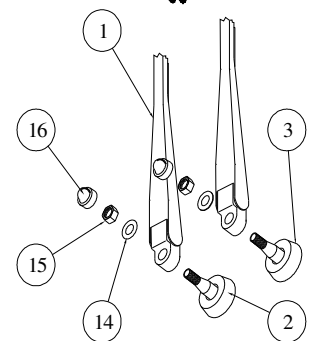
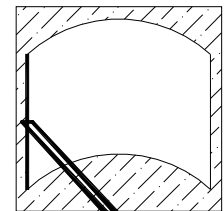
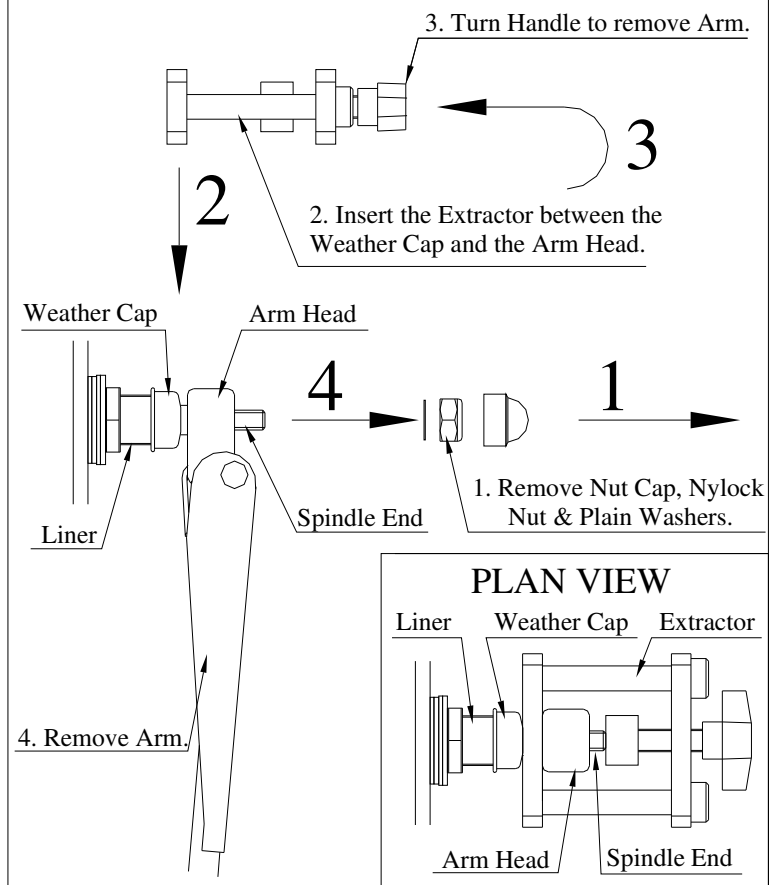

Pendulum Arms Only:

1. Fit Arm onto Spindle allowing Blade to lie approx 50-75mm from edge of glass in PARKED POSITION.
2. Fit a Flat Washer - *(Item 14)* on to spindle next to Arm Head, then a M8 Nylock Nut - *(Item 15)*
3. Only tighten Nut sufficiently to allow Arm and Blade to travel across glass when Motor is run to see if positioning is correct.
4. If incorrectly positioned - DO NOT ATTEMPT TO ROTATE OR TWIST ARM ON SPINDLE this will damage splined end of drive spindle, resulting in Arm and Blade slipping in operation.
5. To correct alignment errors, - loosen Nut and gently pull Arm up Spindle, realign and repeat stages above.
(Arm Extractor Tool is available see Page 13 for instructions)
6. When correctly aligned, tighten M8 Spindle Nut 20Nm. Then fit Weather Cap supplied with Linkage - *(Item 16)*

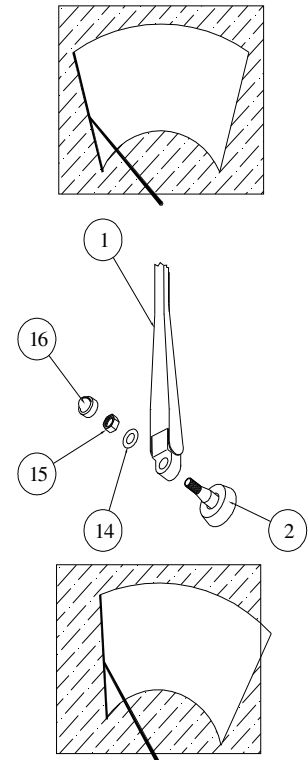

IMPORTANT

On first fitting, check spring pressure on blade in parked position, it must NOT exceed recommended pressure. If this happens contact B. Hepworth. For details see Chapter 4, Table 2 – Continued, Page 16.

CHAPTER 3

Maintenance

Introduction

This chapter contains all preventative maintenance and removal and replacement procedures for the windscreen wiper components. Preventative maintenance procedures include the information required to replace the wiper blades.

Safety Precautions

Always disconnect the power when servicing the Windscreen Wiper System, or on any ancillary components. Serious damage to the Equipment and/or Personal Injury may occur if the power is not disconnected.

Scheduled Maintenance Action Check

Table 1 is a Scheduled Maintenance Action Index. The index provides a list of all performance tests if applicable and preventative maintenance procedures. The table has three columns: Periodicity, Equipment and Task.

The Periodicity column indicates the intervals between the maintenance tests and preventative maintenance procedures.

The equipment column lists the equipment, assembly or subassembly that corresponds to the maintenance action.

The task column lists the maintenance task to be performed.

Table 1

PERIODICITY	EQUIPMENT	TASK
Daily	Wiper Blades	Inspect wiper blades for damage, torn or missing rubber blades. Replace wiper blades as required
Daily	Windscreen Wiper System	Perform function test of wiper washer system. Do not carry out function test on a dry screen
Daily	Washer Tubing and Spray Nozzle	Inspect tubing for damage or loose connection on nozzle. Check operation of spray nozzle on windscreen
Daily	Wash Tank	Insure wash tank is filled with washer fluid to prevent wipers being used on a dry screen
3 Monthly	Fixings of wiper arm to wiper spindle	Check torque settings. (Set torque wrench to correct setting. Fit on nut, turn, if correct, wrench should click.) M8 = 20Nm
Six Monthly or As required	Wiper Blades	Replace wiper blades
6 Monthly	Complete System	Check all torque settings for complete wiper system. M6 = 12Nm (<i>on Motor Bolts</i>) M6 = 18Nm (<i>on Splined Drive Crk Nut & Bolt</i>) M8 = 25Nm (<i>on Coned Drive Crk, Motor Shaft</i>) M8 = 20Nm (<i>on Spindle Nut</i>) M8 = 20Nm (<i>on V. Arc Lever</i>) M20 = 25Nm (<i>on Liner - Metal Bulkhead</i>) Carry out a visual check for wear in rod end. (Pull on tie bar to see if any movement in rod ends bearings at inner ball on outer casing.)

CHAPTER 4

Troubleshooting

Introduction

This chapter provides all the instructions and information necessary to locate problems and conduct tests on the windscreen wiper system components. The trouble-shooting chart is provided for logical isolation of faults.

Safety Precautions

Always disconnect the power when servicing the Windscreen Wiper System, or on any ancillary components. Serious damage to the Equipment and/or Personal Injury may occur if the power is not disconnected.

Troubleshooting Procedures

Typical windshield wiper system troubleshooting procedures are contained in Table 2. These troubleshooting and repair procedures should be followed when encountering operational problems with the windshield wiper system

Table 2

SYMPTOM	PROBABLE CAUSE	TESTS AND CHECKS	CORRECTIVE ACTION
Wiper motor fails to start	On/off switch	Check position of switch	Turn switch to on position
	Voltage Level	Check supply voltage to switch.	Correct voltage supply problem.
	Switch	Check wiring and switch connections	Correct loose wiring connections. Replace broken wires. Replace switch.
	System Jammed	Check wiper linkage	Release linkage. Release wiper arm
	Defective wiper motor		Replace motor
Motor shaft turns but linkage & arm remain static	Defective or loose drive crank	Check linkage for a loose drive crank	Secure or replace drive crank. Clean motor output shaft with wire brush before replacing
Slow Motor Operation	Voltage Level	Check supply voltage to wiper system.	Correct voltage supply problem
	Switch		Replace faulty switch
	Motor Bracket	Check for broken bracket	Replace defective bracket
	Linkage	Check to see if Linkage is free moving	Free linkage replace worn or damaged components
	Defective Wiper Motor		Replace Wiper Motor
System operates but wiper arm remains static	Wiper arm	Check for loose wiper arm connection onto drive spindle	Secure or replace wiper arm after cleaning spindle spline with wire brush. <i>(Ref to Chapter 3, Table 1 for Torque settings.)</i>

Table 2 - Continued

SYMPTOM	PROBABLE CAUSE	TESTS AND CHECKS	CORRECTIVE ACTION
Erratic Motor	Voltage level	Check supply voltage to wiper system.	Correct voltage supply problem
	Switch	Check for loose or broken wires	Replace faulty switch
	Wiring		Repair or replace wiring up to motor. Replace motor if this wiring is damaged
Washer system not working correctly	No water from jets	Check water level in tank	Fill tank
		Check for damage to tank	Replace tank
		Check Pump is operational	Replace pump if faulty
Arm and Blade not operating correctly or over sweep operation	Voltage level	Check supply voltage to wiper system.	Correct voltage supply problem
	Linkage	Check for worn or broken linkage.	Replace Linkage
	Spindle	Check for excessive wear in spindle	Replace Spindle
	Arm	Check that arm is not loose on spindle	Re-tighten Spindle
	Blade	Check for excessive wear on arm	Replace Arm, after cleaning spindle spline with wire brush.
		Check fixing for wear	Replace Blade
		Check blade for wear	Replace Blade
Excessive wear on blade.	Spring pressure.	Check for excessive smearing on screen	Replace Blade
		Use spring balance on centre of blade clip till blade begins to lift off glass. 1 – 1.1/2 kg	Replace spring/arm.

CHAPTER 5

Maintenance Instructions

NOTE: Retain all items removed in a safe place, as they will be required on reassembly. If you experience any difficulty in fitting these units, please do not hesitate to contact us for advice. Use the drawings for reference.

To Replace the Wiper Blade

Removal

With Reference to Figure 4, Page 6.

1. **Internally** - Run motor to insure it is parked correctly. Disconnect all electrical power.
2. **Externally** - Carefully pull wiper arm assembly away from windscreen to enable access to wiper blade.
3. Remove blade retaining screw - **(Item 3)**, and nut - **(Item 4)**, from blade clip on arm.
4. Remove Blade from Blade Clip on Arm.

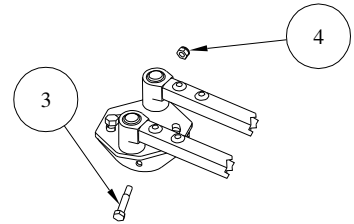

Replacement

1. Place wiper blade into blade clip on arm.

NOTE

Captive end on blade rubber to be at top of screen.

2. Ensure that all fixing holes align. Secure in place with blade retaining screw - **(Item 3)**, and nut - **(Item 4)**.

IMPORTANT

Do not over tighten blade screw and nut, as blade is required to pivot on glass.

3. Lower blade carefully back onto windscreen.

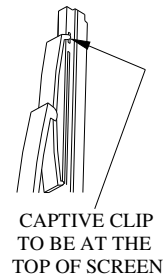

The wiper blades should be changed every 6 months but this is dependent on use and operating conditions

(With Reference to Chapter 3, Table 1 & Chapter 5, Table 2 – continued, Wiper Blades)

To Replace the Wiper Arm

Removal

With Reference to Figure 4, Page 6.

1. **Internally** - Run motor to insure it is parked correctly. Disconnect all electrical power.
2. **Externally** - While Unit is being run it is **IMPORTANT** to observe direction drive spindle rotates in, immediately before it stops. This direction will give **PARK POSITION**.

- Remove 10mm Nut Cap(s) - (Item 16), M10 Nylock Nut(s) - (Item 15) and 10mm Flat Washer(s) - (Item 14). Then using Arm Extraction Tool carefully remove Arm (Arm Extractor Tool is available see Page 13 for instructions)

Replacement

IMPORTANT: - the Blade must be fitted to the Arm prior to the Arm being fitted. (This is to prevent the Blade Clip damaging the screen,)

(Refer to fitting instructions for replacement, Page 12)

To Replace the 24v Drive Crank/Double Bearing Assembly

Figure 10 – 24v Units

ITEM	DESCRIPTION	QTY
4	Drive Crank Sub Assy 30 Crs	1
5	Double Bearing – 124 Crs	1
6	50Nm (IER) Motor	1
18	M6 Fixing Bolts	3
19	M8 Securing Bolt	1
20	M8 Securing Nylock Nut	1
25	8mm Washer – Flat	1
26	M8 Securing Nylock Nut	1
27	V.Arc Bearing Pivot Pin	1

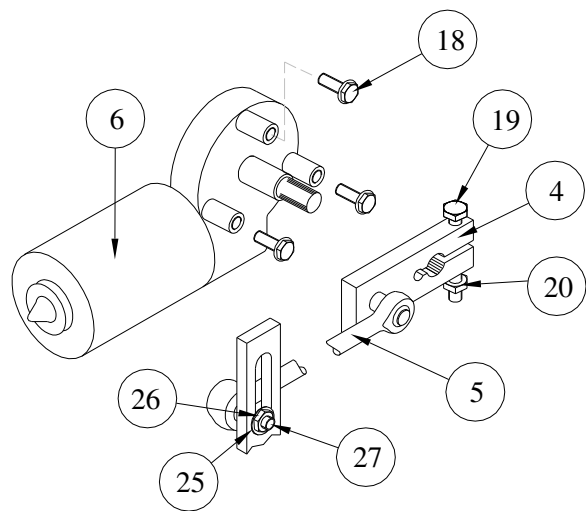

Removal

IMPORTANT:

Please make a note of Drive Crank POSITION relative to SPINDLE LEVER, as this will affect PARK position for ARMS and BLADES, i.e. SPINDLE LEVER facing towards Motor or away from Motor

Make a note of Vari Arc Pin/Double Bearing position on Vari Arc Lever.

- On Vari Arc Lever, unscrew M8 Securing Nylock Nut - (Item 26). Remove it and Washer - (Item 25). Slide out V.Arc Bearing Pivot Pin - (Item 27) complete with Double Bearing - (Item 5)
- Slacken Drive Crank Nut - (Item 20), and Bolt - (Item 19), carefully remove Drive Crank/Double Bearing Assy - (Item 4), from Motor Drive Shaft.

Replacement

- From Inside Unit - Carefully fit Drive Crank/Double Bearing Assy - (Item 4), over Motor Drive Shaft, (refer to the Note after operation 1 on 'Removal' for position.)

2. Fit V.Arc Bearing Pivot Pin – (Item 27) complete with Double Bearing - (Item 5) through Vari Arc Lever. Replacing in same hole position (refer the Note before operation 2 on 'Removal' for position.) for correct setting of arc on replacement
3. Tighten Drive Crank Nut - (Item 20), and Bolt - (Item 19).

To Replace the 12v Drive Crank/Double Bearing Assembly

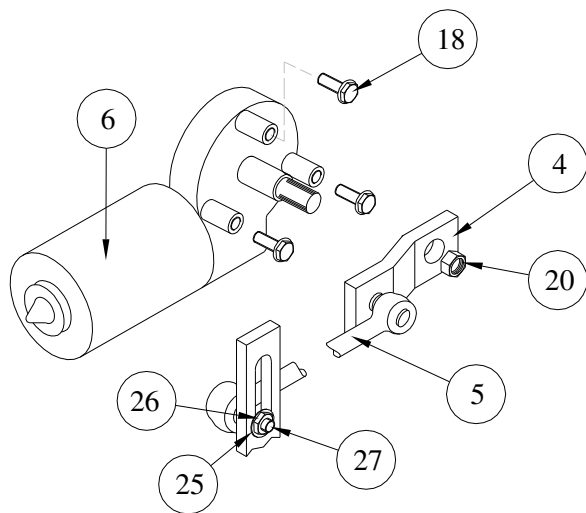

Figure 10 – 12v Units

ITEM	DESCRIPTION	QTY
4	Drive Crank Sub Assy 30 Crs	1
5	Double Bearing – 124 Crs	1
6	50Nm (IER) Motor	1
18	M6 Fixing Bolts	3
20	M8 Securing Nut	1
25	8mm Washer – Flat	1
26	M8 Securing Nylock Nut	1
27	V.Arc Bearing Pivot Pin	1

Removal

1. **Internally** - Run motor to insure it is parked correctly. Disconnect all electrical power.

IMPORTANT

Please make a note of Drive Crank POSITION relative to SPINDLE LEVER, as this will affect PARK position for ARMS and BLADES, i.e. SPINDLE LEVER facing towards Motor or away from Motor

Make a note of Vari Arc Pin/Double Bearing position on Vari Arc Lever.

2. On Vari Arc Lever, unscrew M8 Securing Nylock Nut – (Item 26). Remove it and Washer – (Item 25). Slide out V.Arc Bearing Pivot Pin – (Item 27) complete with Double Bearing - (Item 5)
3. Unscrew Drive Crank Nut - (Item 20), carefully remove Drive Crank/Double Bearing Assy - (Item 4), from Motor Drive Shaft.

Replacement

1. **From Inside Unit** - Carefully fit Drive Crank/Double Bearing Assy - (Item 4), over Motor Drive Shaft, (refer to the Note after operation 1 on 'Removal' for position.)
2. Fit V.Arc Bearing Pivot Pin – (Item 27) complete with Double Bearing - (Item 5) through Vari Arc Lever. Replacing in same hole position (refer to the Note before operation 2 on 'Removal' for position.) for correct setting of arc on replacement
3. Tighten Drive Crank Nut - (Item 20).

To Replace the Lever/Liner/Spindle Sub Assembly

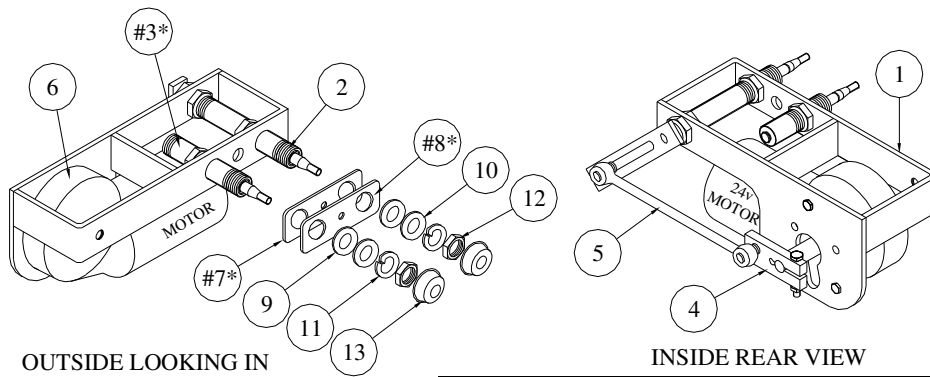

ITEM	DESCRIPTION	QTY	QTY	
			PANTO	PEND
1	Motor Mounting Bracket	1		
2	Liner V.Arc Lever Sub Assy	1		
#3*	Idler Liner Sub Assy (Panto Only)	1		
4	Drive Crank Sub Assy 30 Crs	1		
5	Double Bearing - 124 Crs	1		
6	50Nm (IER) Motor	1		
#7*	Idler Gasket (Panto Only)	1	1	--
#8*	Idler Plate (Panto Only)	1	1	--
9	20mm Washer - Neoprene	2	2	1
10	20mm Washer – Flat	2	2	1
11	20mm Washer – Single Coil	2	2	1
12	M20 Hex. Nut	2	2	1
13	20mm Weather Cap	2	2	1

Removal

1. **Internally** - Run Motor to insure it is parked correctly. Disconnect all Electrical Power.

IMPORTANT

Externally - Please make a note of **PARKED** position of **ARMS** and **BLADES**.

2. Remove Wiper Arm and Blade
Ref. Chapter 5, To Replace the Wiper Arm - Removal.
3. Remove 20mm Weather Caps - (Item 13), M20 Nuts - (Item 12), Single Coil Washers - (Item 11), Flat Steel Washers - (Item 10), Neoprene Washers - (Item 9), On Pantograph units only Idler Plate - (Item 8) and finally Idler Plate Gasket - (Item 7).
4. NOTE: - Keep safe as will be required on reassembly

IMPORTANT

Please make a note of Drive Crank **POSITION** relative to **SPINDLE LEVER**, as this will affect **PARK** position for **ARMS** and **BLADES**, i.e. **SPINDLE LEVER** facing towards **Motor** or away from **Motor**

Make a note of Vari Arc Pin/Double Bearing position on Vari Arc Lever.

5. On Vari Arc Lever, unscrew M8 Securing Nylock Nut - (Item 26). Remove it and Washer - (Item 25). Slide out V.Arc Bearing Pivot Pin - (Item 27) complete with Double Bearing - (Item 5)

IMPORTANT

Make a note of protrusion length of Liner and/or Spindle from front of Bracket - (Item 1)

6. Unscrew and remove entire Liner/Vari-Arc Lever Assembly from Bracket.

Reassembly

1. Screw entire Liner/Vari- Arc Lever Assembly into Bracket.
2. Fit V.Arc Bearing Pivot Pin – *(Item 27)* complete with Double Bearing – *(Item 5)* through Vari Arc Lever. Replacing in same hole position (*refer Note before operation 5 on ‘Removal’ for position.*) for correct setting of arc on replacement
3. Replace Liner Nuts and Weather Caps on to Liners. Replace Arm and Blade (*Refer to fitting instructions for replacement*)

Vari Arc Units - Arc adjustment

For Instructions on adjustment see Diagram, Page 9

CHAPTER 6

Operation Instructions

Switch Operation – Multi-Switch

1. Check switch is in off position before starting. (**OFF/PARK**)

IMPORTANT DO NOT RUN WIPERS ON A DRY SCREEN.

2. To apply water to screen, press knob. (**WIPER WASHER**) This will apply water for duration of pressing button. The wiper will also operate for 3-4 wipes at normal speed after water stops.
3. Turn knob **CLOCKWISE** it will (**CLICK**) which turns wipers on. The switch is now in the area of variable intermittent wipe cycle time. Which is between (**ON-LONG DELAY**) and (**ON-SHORT DELAY**) positions.

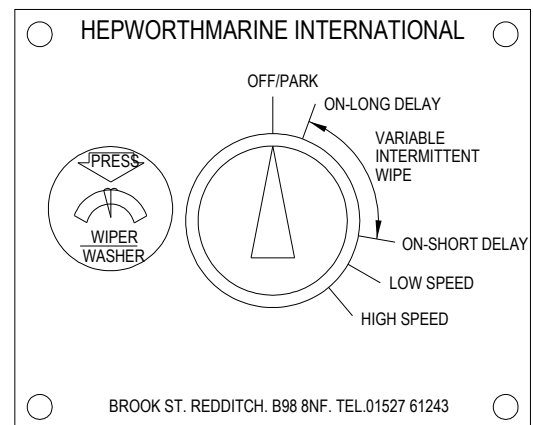

4. The further clockwise knob is turned between the two positions shorter the delay between wipes.
5. Turn knob **CLOCKWISE** to next (**CLICK**) (**LOW SPEED**) gives a continuous wipe across screen at a standard speed, with no delay between wipes.
6. Turn knob **CLOCKWISE** to last (**CLICK**) (**HIGH SPEED**) gives a continuous wipe across screen at a faster speed, with no delay between wipes.
7. Turn knob **ANTI-CLOCKWISE** to off position when finished. (**OFF/PARK**)

Switch Operation – Toggle Switch

1. Check switch is in off position before starting. (**OFF/PARK**)

IMPORTANT DO NOT RUN WIPERS ON A DRY SCREEN.

2. This Switch does not control water.
3. Pushing Toggle to centre position (**SLOW**) gives a continuous wipe across screen at a standard speed, with no delay between wipes.
4. Pushing Toggle to bottom position (**FAST**) gives a continuous wipe across screen at a faster speed, with no delay between wipes.
5. Push Toggle to top position when finished. (**OFF/PARK**)

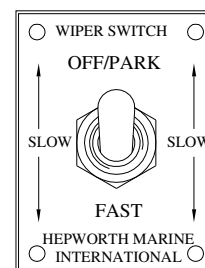

Switch Operation – Rotary Switch

1. Check switch is in off position before starting. (**OFF/PARK**)

IMPORTANT DO NOT RUN WIPERS ON A DRY SCREEN.

2. To apply water to screen, press knob. (**WIPER WASHER**) This will apply water for duration of pressing button. (Note – it does not activate wiper)
3. Turn knob **CLOCKWISE** it will (**CLICK**) which turns wipers on, (**ON**). This setting gives a continuous wipe across screen at a standard speed, with no delay between wipes.
4. Turn knob **CLOCKWISE** to last (**CLICK**) (**FAST**). This setting gives a continuous wipe across screen at a faster speed, with no delay between wipes.
5. Turn knob **ANTI-CLOCKWISE** to off position when finished. (**OFF/PARK**)

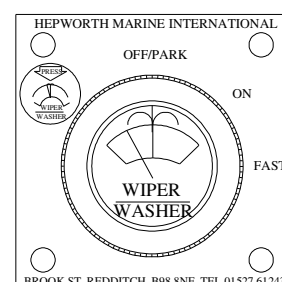

Note – for other all other switch or control instructions refer to the ship's fitters/suppliers manual.

SPARES LIST

(Ref Figures 1 & 2, Pages 4 & 5.)

<i>Part No.</i>	<i>Description</i>	<i>Qty</i>
50NM240VA###12C	50Nm 24v Complete Motor Unit - Pantograph	As Required
50NM240VA###00C	50Nm 24v Complete Motor Unit - Pendulum	As Required
50NM120VA###12C	50Nm 12v Complete Motor Unit – Pantograph	As Required
50NM120VA###00C	50Nm 12v Complete Motor Unit - Pendulum	As Required

Component parts of Unit

60663800	Mounting Bracket Assy (<i>Item 1</i>)	1 per unit
650090##	Liner/Lever/Bearing Sub Assy (<i>Item 2</i>)	1 per unit
650091##	Idler Liner Sub Assy (Pantograph Units Only) (<i>Item 3</i>)	1 per unit
65009300	50Nm 24v D. Crk/Bearing S. Assy – 30 Crs (<i>Items 4 & 5</i>)	1 per unit
65009401	50Nm 12v D. Crk/Bearing S. Assy – 30 Crs (<i>Items 4 & 5</i>)	1 per unit
100865/2	50Nm 24v Motor IER. (<i>Item 6</i>)	1 per unit
100860/2	50Nm 12v Motor IER. (<i>Item 6</i>)	1 per unit

Fittings for M20 Liners and 12mm Spindles protruding outside the Bulkhead

<i>Part No.</i>	<i>Description</i>	<i>Qty</i>
60267900	Idler Gasket (<i>Item 7</i>)	1 per liner
60119600	Idler Plate (<i>Item 8</i>)	1 per liner
10020600	20mm Neoprene Washer (<i>Item 9</i>)	1 per liner
10024300	20mm Plain Washer (<i>Item 10</i>)	1 per liner
10028400	20mm Single Coil Washer (<i>Item 11</i>)	1 per liner
10011900	M20 Hex Nut (<i>Item 12</i>)	1 per liner
60034600	20mm Weather Cap (<i>Item 13</i>)	1 per liner
10022500	M8 Plain Washer (<i>Item 14</i>)	1 per liner
10013900	M8 Nylock Nut (<i>Item 15</i>)	1 per liner
10060300	8mm Nut Cap (<i>Item 16</i>)	1 per liner

(Ref Figure 4 – Pantograph, Page 6.)

<i>Part No.</i>	<i>Description</i>	<i>Qty</i>
P615 Length TJ	Nom. 20” – 28” TJ Panto Arm – 50 Crs 14mm B. Clip (<i>Item 1</i>)	1 per unit
P620 Length TJ	Nom. 20” – 28” TJ Panto Arm – 50 Crs 20mm B. Clip (<i>Item 1</i>)	1 per unit
B140 Length #	14” – 28” Curved Blade (<i>Item 2</i>) – 14mm Saddle	1 per unit
B140 Length #	32”,36” &39” Curved Blade (<i>Item 2</i>) – 20mm Saddle	1 per unit

(Ref Figure 4 – Pendulum, Page 7.)

<i>Part No.</i>	<i>Description</i>	<i>Qty</i>
F75 Length TJ	Nom. 20” – 28” Straight Pendulum Arm (<i>Item 1</i>)	1 per unit
B140 Length B	14” – 28” Curved Blade (<i>Item 2</i>)	1 per unit

Fittings for Arm and Blade

<i>Part No.</i>	<i>Description</i>	<i>Qty</i>
80205600	Pantograph - Blade Retaining Screw (14mm B. Clip) (<i>Item 3</i>)	1 per arm
80204600	Pendulum - Blade Retaining Screw (14mm B. Clip) (<i>Item 3</i>)	1 per arm
10011400	M4 Nylock Nut (<i>Item 4</i>)	1 per arm

(Pages 11 & 12.)

<i>Part No.</i>	<i>Description</i>	<i>Qty</i>
90041000	1 x 12v Multi Switch & Plate (<i>Page 10</i>)	1 per unit
90087010	1 x 24v Multi Switch & Plate (<i>Page 10</i>)	1 per unit
90041400	1 x 12/24v Toggle Switch & Plate (<i>Page 10</i>)	1 per unit
90043000	1 x 12/24v Rotary Switch & Plate (<i>Page 11</i>)	1 per unit

(Ref Page 13.)

<i>Part No.</i>	<i>Description</i>	<i>Qty</i>
60680600	Arm Extractor Tool - All Head Types	As Required

**We represent this supplier.
For more information contact
Observator Vision:**

**T: +31 (0)85 0436000
E: vision@observator.com**

Zernikestraat 51
3316 BZ Dordrecht
The Netherlands

Welcome to the world of Observator

Since 1924 Observator has evolved to be a trend-setting developer and supplier in a wide variety of industries. Originating from the Netherlands, Observator has grown into an internationally

oriented company with a worldwide distribution network and offices in Australia, Germany, the Netherlands, Singapore and the United Kingdom.

www.observator.com