



OMC-116M (Marine Type Bracket)



OMC-116

Datasheet

OMC-116(M) Full metal Ultrasonic Wind sensor

Marine meteorological observations require devices designed to withstand the hardest environmental conditions such as heavy vibrations, sea spray, extremes of temperature, chemical particles etc. Observator has an exceptional track record in the world-wide supply of meteorological sensors to the marine and offshore markets.

The OMC-116M is a ultrasonic wind sensor based on the time of flight theory designed specifically for the rigors of the marine markets. The unit offers the industrial standard NMEA0183 output and also offers optional 4..20 mA outputs.

The robust design of stainless steel and marine grade aluminum makes this unit ideal for the hardest of environments. Heating is available as standard making the sensor suitable in operating temperatures down to -40°C .

The standard mounting bracket with its integrated junction box makes this unit easy to install.

Features

- High accuracy maintenance free sensor
- Range 0-90 m/s
- Fitted with an integrated heater (240 Watts, controlled separately)
- Power supplies optional available. OMC-2671, output 12 Vdc for non-heated sensor, OMC-2675, output 24 Vdc, 10 A for heated sensor.
- Supplied with calibration certificate
- Easy to install
- Integrated junction box
- Standard NMEA0183 output, RS422 (baud rate user selectable)
- Optional 4..20 mA outputs

www.observator.com

General

The OMC-116M Ultrasonic wind speed and direction sensor comes standard with an industrial mounting bracket provided with 2 U-bolts suitable for mast mounting (max 65 mm dia.). An integrated junction box allows easy connection of sensor signal and power supply using standard cabling. The internal heater should be powered separately if used. The sensor can be configured to enable or disable the heater. In applications where heating is not required (and hence disabled), the OMC-116 can be powered directly from an Obsermet display or data logger. In cases where the heater is to be used (advised in cases where temperatures below zero may be expected) an external 24Vdc power supply should be used with a capacity of not less than 250 watts. The unit comes complete with a calibration certificate at no extra cost. Although the unit is maintenance free and does not need re-calibration, it is possible to return the sensor to Observator for a re-calibration if required.

Data summary

Wind speed

- principle Ultrasonic
- range 0-90 m/s
- accuracy ± 0.2 m/s or ± 2 % RMS of reading (whichever is greater) for 0...65 m/s - otherwise ± 5 %
- threshold 0.1 m/s

Wind direction

- principle Ultrasonic
- range 0..359.9°
- accuracy $\pm 2^\circ$ RMSE > 1.0 m/s
- threshold 0.1°

Power requirements

- Power supply 10 - 30 Vdc
- Current, no heating 125mA@ 12 Vdc
- Current with heating 10A@ 24 Vdc

Outputs

- NMEA0183 version 2.30
- RS422, baud rate selectable
- Identifier selectable
- Optional 4..20 mA outputs (2)

Welcome to the world of Observator

Since 1924 Observator has evolved to be a trend-setting developer and supplier in a wide variety of industries. Originating from the Netherlands, Observator has grown into an internationally

Dimensions OMC-116 (land version)

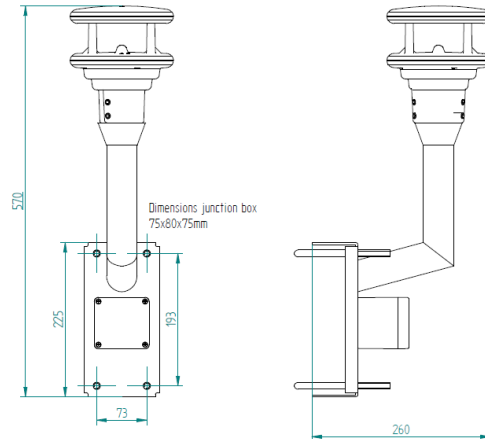

Dimensions OMC-116M (marine version)

- Weight 4 kgs
- Mounting arm with two U-bolts for pole max 65 dia

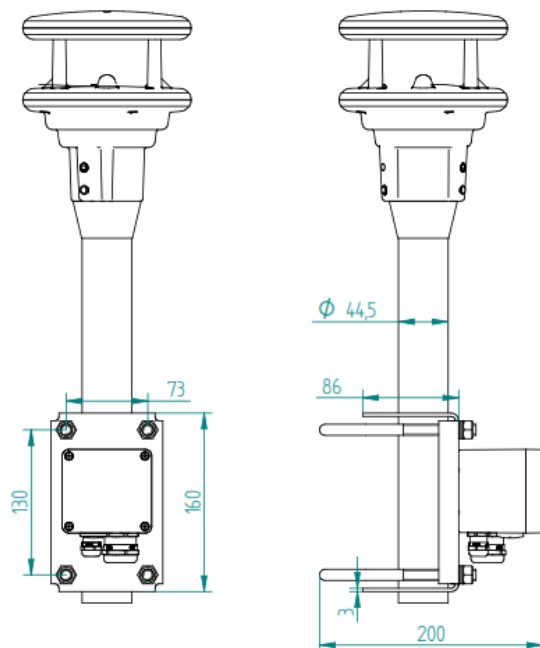

Environmental

- Operation temperature $-20^\circ..+60^\circ\text{C}$
- With heater $-40^\circ..+60^\circ\text{C}$
- Moisture protection IP66
- Humidity 0..100% RH