



Wynn Marine Ltd  
2-4 Merse Road, North Moons Moat, Redditch, Worcestershire B98 9HL, United Kingdom  
Tel: +44 (0) 1527 61243, Fax: +44 (0) 1527 66836  
Email: [info@wynn.co.uk](mailto:info@wynn.co.uk), website [www.wynn.co.uk](http://www.wynn.co.uk)

## **Installation & Maintenance Manual**

### **Type D MKII Straight Line Wiper**

#### **With Pneumatic Motor**

# 1 Type D MKII Pneumatic Description and Specification

The 'Type D Mk II' is a Heavy Duty Straight Line Wiper with a pneumatic motor mounted externally in a housing protected to IP67. The standard motor housing position is normally supplied on the left side of the unit (mounted above the window and viewed looking into the window).

De-icing heaters are optional. Fitted inside the wiper case to ensure effective operation in cold conditions.

Spray nozzles / water connections are supplied. A fresh water supply can be plumbed directly onto the wiper. The installer needs to provide pressurised water supply and the interconnecting plumbing.

The vane motor fitted to the wiper is designed to provide high performance with high standards of reliability. This means a high power to volume ratio, a low air consumption and long vane life. All motors utilise 5 vanes to ensure excellent starting and high speed performance. See below for technical specifications.

## Motor Specification

Motor	Type	Maximum Output Kw (hp)	Torque @ max. output Nm (lb/ft)	Max. starting torque Nm (lb/ft)	Free speed rpm	Air consumption @ max. power L/s (cfm)
1588-608	Non reversible vane motor	.61 (0.0816)	201.6	2.2 (1.63)	629	2.2 (4.64)

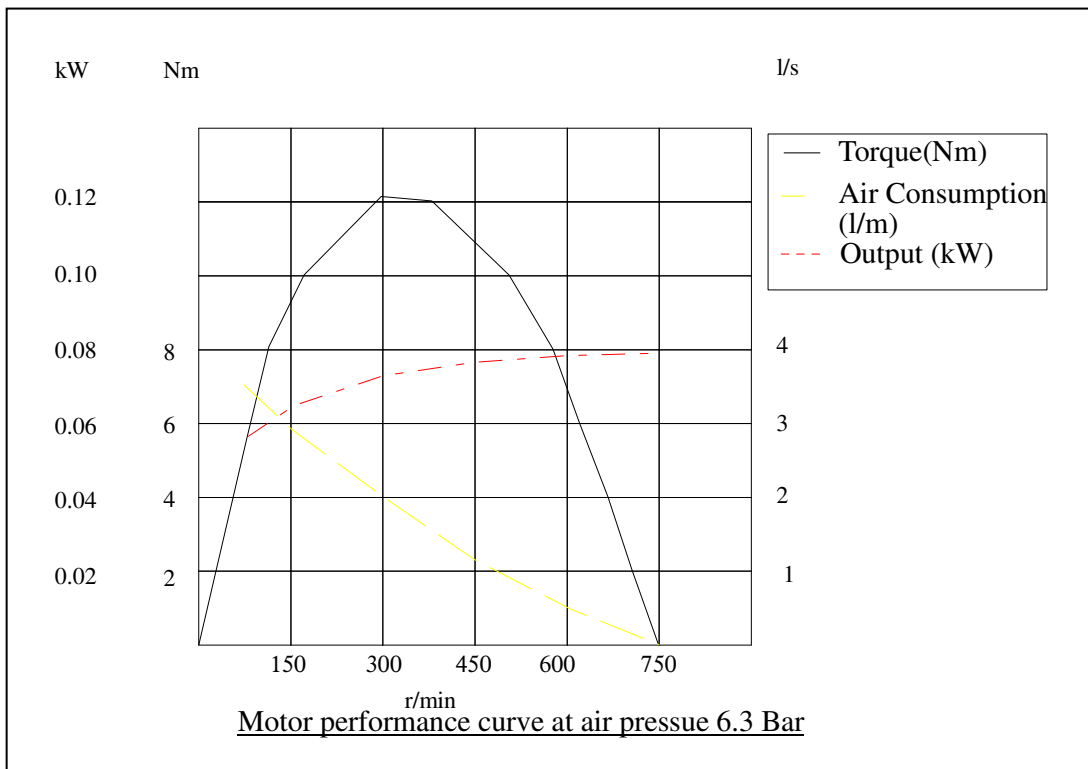

When the wash option is installed, the maximum pressure for the system is 8 bar or 118 PSI and the minimum pressure for adequate spray reach is 1 bar or 15 PSI. Example flow rates for a single spray jet are shown below.

## Water System Pressure And Flow Rates

Pressure		Flow rate	
bar	psi	Litres/min	Gallons/min
1.0	15	0.95	0.20
1.5	22	1.20	0.25
2.0	29	1.40	0.30
3.0	44	1.75	0.40

## 2 Type D MKII Installation



**CAUTION:** Ensure that the correct wiper, blade and arms are selected for each window.

**CAUTION:** Before drilling, ensure that there are no obstructions / hazards at the chosen mounting position. The main frame should be mounted on a flat surface that will not bend or twist the casing, as this will prevent correct operation of the wiper.

**CAUTION:** Where more than one wiper unit is to be mounted close together, allow a distance of 70mm minimum between the wiper units.

1. Peel off the backing from self-adhesive template provided. Fix the template to the outside of the mounting bulkhead, in the mounting position (either above or below the window).
2. Drill the wiper 2 off fixing holes (11 mm diameter).
3. Detach the back casing from main unit. Hold the wiper back casing in the required position and mark-out the remaining two wiper fixing holes, or calculate stroke length plus 172 mm.
4. Drill the remaining wiper fixing, and air supply line holes for the motor and heater cable, ensuring that all holes are de-burred. Treat bare metal to prevent corrosion.

**NOTE:** Ensure that at the chosen mounting location, the casing can be removed for maintenance and that the chosen mounting surfaces will not cause the Main Frame to be bent or twisted on installation since this will prevent correct operation of the wiper.

5. Fit the wiper back casing in the required position and secure with four M10 bolts. Ensure that the bolts are sealed where they pass through the bulkhead.
6. Pass the flexible air supply line through the bulkhead, leaving a loop as required, and seal.
7. Using the supplied M6 x 10mm screws, secure the blade arm assembly to the carriage plate.



**CAUTION:** Ensure the correct length screws are used, as supplied. Longer screws will cause the carriage assembly to jam.

8. Offer the front casing up to the back casing. Bolt the front casing to the back casing using the 2 off M10 bolts fitted into the case.
9. If necessary, slacken the screws on the blade attachment clip, move the blade up or down for optimum position and then retighten screws.
10. Move the blade assembly over its full stroke and check that there is no restriction to movement (the motor will offer some resistance, but should not jam the wiper). Investigate and rectify any restrictions.
11. Run the airlines according to the installation drawing overleaf and instruction below.

**NOTE:** Ensure that the hose dimensions given in the installation drawing are adhered to (i.e. exhaust hose larger than inlet hose) and that the lengths are within given limits (less than 3m). Output of the motor will be affected if these guidelines are not followed.

To ensure reliable service an air filter and lubricator should be fitted into the airline – within 5 metres of the motor. The lubrication oil selected should have a viscosity that lies between  $50$  and  $300 \times 10^6$   $\text{m}^2/\text{s}$  at the motors working temperature. The motor should be lubricated with  $50 \text{ mm}^3$  of oil for each cubic metre of air consumed. When operated at the maximum recommended rate, this equates to a 1 drop every 3.3 minutes (assuming each drop is  $15\text{mm}^3$ ).

12. Fit the pressure regulator (1588-610) and on/off valve (1588-609) in the inlet airline (1690-036) in the order shown in the installation drawing, connected via the male stud coupling (1588-617).
13. Ensure that the inlet tubing is connected to inlet marked 2 using male stud coupling (1588-613).
14. Fit male stud coupling (1588-613) into exhaust port and connect 200 mm of 8 mm tubing (1690-036). Using 10 mm to 8 mm reducing connectors (1588-614 and 1691-022), attach a length of 10 mm hose and terminate using silencer nozzle (1588-616 and 1588-615). This must be made to reduce noise.
15. Once connected to the air supply, the wiper is ready for functionality test.

## 3 Operating Instructions

1. Set wiper switch (1588-609) to the off position. Apply air to the system.
2. Turn the switch on. The wiper should start and run.
3. Turn the wiper switch off. The wiper should stop.
4. If the wiper fails to start, increase the flow regulator (1588-610) by turning the control Knob until the wiper starts. **NOTE:** Ensure that the wiper does not operate at a rate above 80 metres per minute.
5. If fitted, press the wash switch (not supplied) and check that water is delivered from the nozzles.

# 4 Pneumatic Motor Installation Drawing

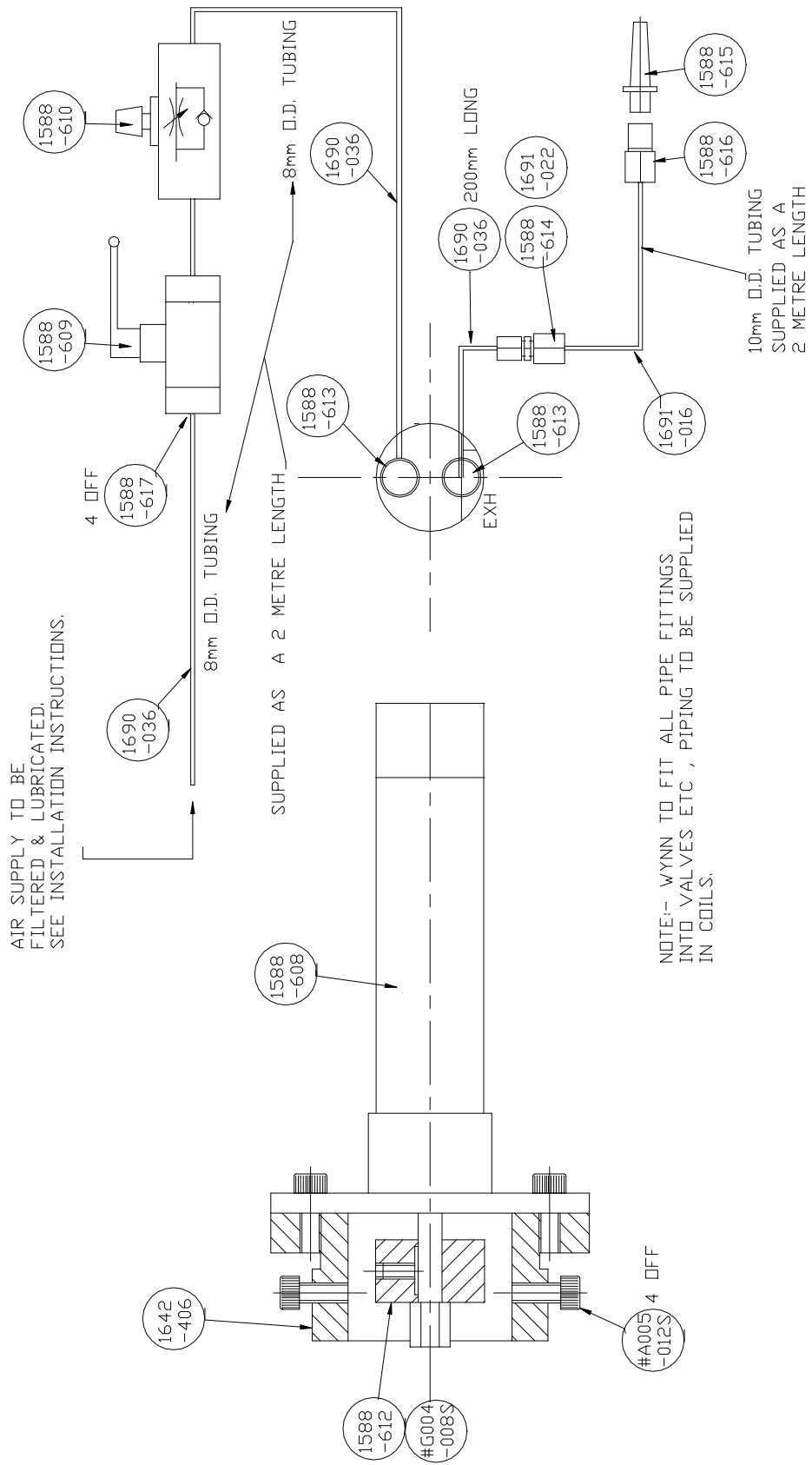

## 5 Type D MKII Wiper – Single Wiper Dimensions

Ignore references to Motor, Heater and Park cables or glands.

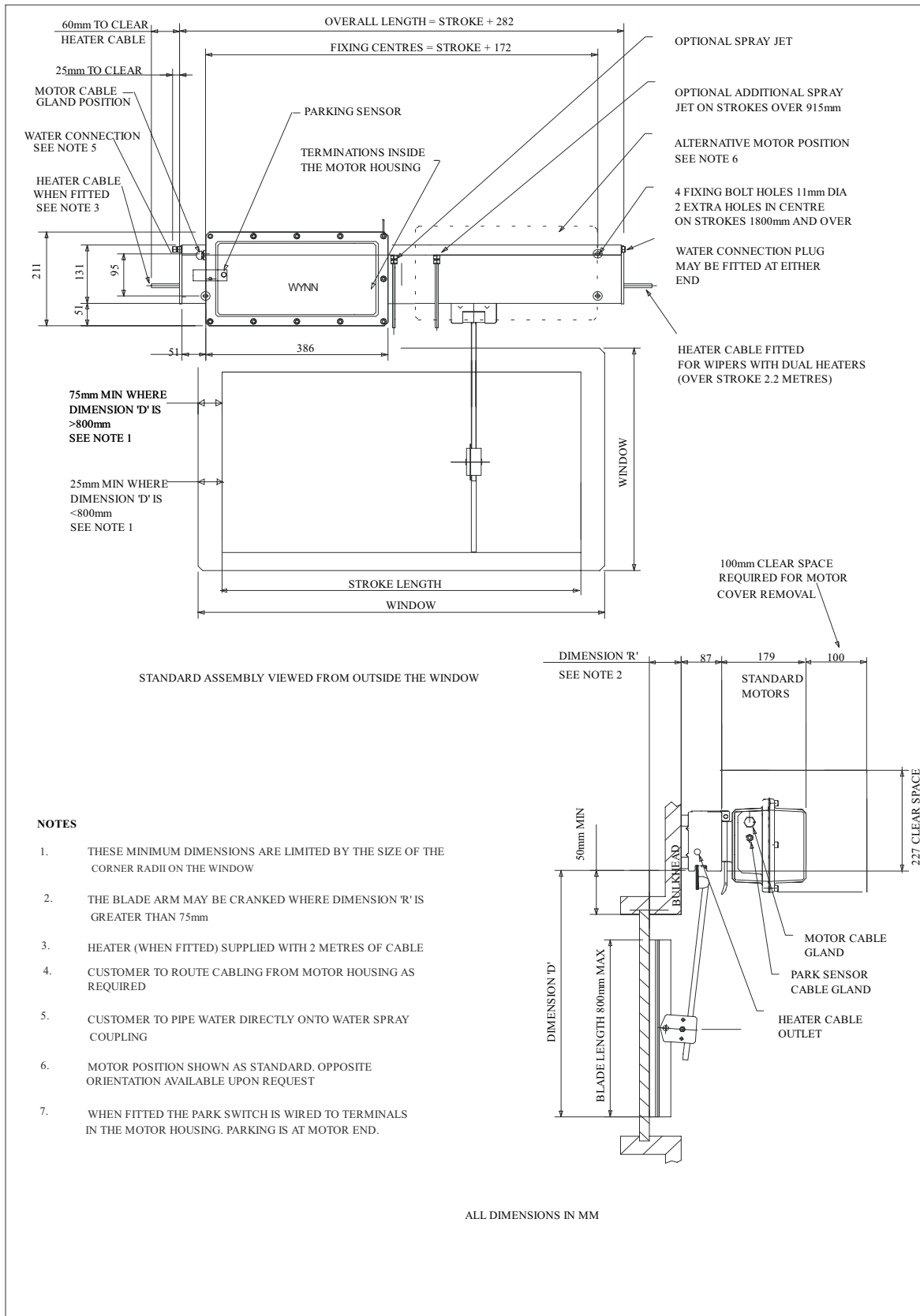



## 7 Type C Wiper Maintenance

Wynn products have been proven over many years to perform well under the harshest condition of use. To maintain their performance the following schedule is recommended:

### Every 6 Months

Replace Articulated Blades.

#### DC motors only

1. Inspect the motor brushes. Remove motor end cover. Prevent brushes from running down to less than 6mm height in service. Brushes can be lifted out of their holder after lifting off the springs. Replace brushes back into same holder and in the same orientation. Ensure that the brush 'pig tails' is free and that the springs are correctly replaced.
2. When replacing brushes, carefully clear out any residual carbon dust from the motor.



**WARNING:** DO NOT INHALE THE CARBON DUST.

3. Inspect the motor commutator – it should still be bright. If it is blackened the motor should be replaced or serviced. This can be done with light cleaning with 'flour' paper, but not 'emery' paper.

### Every 12 Months

Check condition of the Rigid Wiper Blade. Replace if necessary.

1. Check Heaters if fitted. If these have not been used for some time, then leave them on for approximately 2 hours.  
**NOTE:** If not used for long periods, some mineral insulated heaters will take up moisture and begin to show current leakage to ground. By running them for the stated time this process can be reversed and the insulation returned to near infinity values. When dry, insulation resistance is > 100 M ohm at 500V.
2. Check the drive belt for deterioration. Replace if necessary.
3. Check carriage is smooth and all guide rollers are free to rotate. Inspect 'tyres' on the guide rollers for splitting / perishing. Replace complete roller if necessary.



**Caution:** Guide rollers have an integral water lubricated bearing and **MUST NOT** be grease lubricated.

4. Check for free movement of idler pulleys in response to belt tension. Lubricate as necessary with water resistant grease.
5. Ensure free movement of drive pulley. Replace if damaged or when showing signs of excessive wear.  
**NOTE:** The drive pulley is jig assembled and should not be dismantled.
6. Check for free blade arm spring movement. Dismantle, re-grease or replace if necessary.

## 8 Type D Inspection / Renewal of Parts



**WARNING:** To ensure health & safety, **remove** power from the control unit, before working on any parts of the wiper either inside or outside.

### Drive Belt

1. Undo the front casing bolts, disengage front assembly from rear casing and support it without causing undue strain at the cables. Alternatively, open motor enclosure, disconnect wiring and draw cables out of glands. Lift off whole of front casing assembly.
2. Remove the blade assembly. Carefully retain the special short screws.
3. Slip the belt off the spring-loaded pulleys then slide the carriage/belt assembly out of the end of the case at the idler pulley end. Note: the assembly can also be removed from the drive pulley end.
4. Inspect the drive belt and replace if damaged or worn. To detach the drive belt, note how the parts are assembled, then undo the 2 small nuts securing the belt to the clip.
5. Fit a new belt. Spare belts are supplied with nuts and clip plate. Refit and tighten nuts to the same height as the original and secure by Loctite thread lock (or similar).
6. Fit the carriage/belt assembly back into the casing and slip the belt onto the idler pulley and then the drive pulley.

7. Move the carriage by hand and ensure that it travels the full stroke length freely and without any obstruction. (Motion will feel restricted because the motor is being rotated). Refit the blade assembly with special screws as removed in instruction 2. Refit the front casing to the back casing and secure with the 2 off M10 cover bolts.
8. If front casing was completely removed, ensure that connections are remade.

### Guide Rollers

1. Follow instructions drive belt renewal instructions 0 to 3 above.
2. Remove the roller stub shaft securing the guide roller and remove the guide roller.
3. Fit the new guide roller and secure with the roller stub shaft. Ensure that roller stub shaft is tightened firmly.
4. Re-assembly is reversal of above instructions.



**CAUTION:** Rollers have an integral water lubricated bearing and **MUST NOT** be oil or grease lubricated.

## 9 Fault Finding Guide

This guide will assist the installer to ensure the wipers will operate without failure after installation.

### Problems: With switch on, the wiper does not work.

<b>Possible Cause</b>	<b>Solution</b>
Air not reaching motor	Check compressor is functioning correctly. If possible confirm (with gauge) air is present at switch outlet and input ports and at the motor input port. Inspect piping and associated equipment for leaks. Repair/replace as necessary.
Connections to motor incorrect.	Check piping according to the installation drawing.
Insufficient air pressure at motor.	The motor is designed to operate at approximately 4 bar. If the motor is not supplied with sufficient pressure, the performance drops. Measure the pressure as close to the motor as possible.
Wiper motor not fully engaged on coupling. (Straight line wipers only)	Slacken pinch bolt, move motor and/or wiper arm to align coupling and push motor into engagement with coupling. Retighten pinch bolt. Make sure that the rubber coupling is fitted
Carriage motion jammed. (Straight line wipers only)	It should be possible by pushing the blade arm to move the mechanism over the stroke length. Remove cover and check for obstructions.
Drive pulley turning but belt slipping. (Straight line wipers only)	Excessive friction - Check carriage rollers and motor drive coupling. Replace as required. Idler pulley springs broken or missing. Replace.
Drive belt broken or damaged. (Straight line wipers only)	Inspect belt for slip or burn damage. Belt at end of life. Replace.
Idler pulley jammed. (Straight line wipers only)	Damaged by impact, or bearing system failed. Replace assembly.
Motor vanes worn out	Replace

### Problem: Wiper runs but at wrong speed

<b>Possible Cause</b>	<b>Solution</b>
Air pressure too low.	Measure the pressure as close to the motor as possible. (should be 4 bar)
Motor vanes worn out	Replace



**Problem: Wiper does not clean the screen properly.**

<b>Possible Cause</b>	<b>Solutions</b>
Blade not in contact with screen.	Blade or arm bent - inspect and replace. Arm pivots seized due to corrosion - replace. Heaters ineffective allowing ice build up.
Weak springs on blade arm.	Stronger springs may be required. Contact Agent/Distributor
Broken springs on blade arm.	Investigate reason of failure and replace. Springs are good down to -40°C.
Blade rubber missing or damaged.	Maintenance item. Replace as required.

**Problem: If fitted, little or no washer water comes out when button pressed.**

<b>Possible Cause</b>	<b>Solution</b>
Pump or supply pressure too low.	Check Ship's water supply, or pump for output pressure.
On reservoir systems, empty.	Check - refill.
Water control valve faulty or not operating.	Check solenoid valve continuity. Replace if open circuit.
Supply lines or jets blocked.	Try air purge, if available. Dismantle and flush pipes.
Water frozen.	Switch on heaters.

**Problem: Wiper runs but is noisy**

<b>Possible Cause</b>	<b>Solution</b>
Incorrect blade arm attachment screws.	Only correct length screws to be used to attach arm to carriage. Check and replace.
Wiper arm striking edge of window, spray jet or other external obstruction.	Inspect, if required gently bend any spray jets out of path of wiper arm.
Cover not secured on wiper.	Check and tighten fixing screws.
Carriage rollers noisy.	Maintenance item - replace.
Air leaks	Check all connectors and piping for air leaks – repair or replace as necessary.
Motor exhaust silencer not fitted	Check silencer is fitted and working with no leaks.

## 10 Type D MKII Pneumatic Wiper Spares List

Ident	Description	Quantity	Part Number
1	Heavy duty Blade Assembly	1	1688-001-***
	Articulated Blade Assembly	1	1279-553-***
2	Blade Attachment Clip (Stainless Steel)	1	1279-443
3	Either - Blade Arm Assembly - Standard	1	DD**R*
	Or - Blade Arm Assembly - Square	1	DD**S*
4	Blade Arm Torsion Spring	1	1292-221
5	Blade Arm Pivot Blocks	Pair	1279-486-###
6	Arm Attachment Screws	Set of 3	1588-488
7	Carriage Plate Assembly – Twin Blade	1	1588-312
8	Guide Rollers c/w Tyre	Set of 8	1588-117
	Guide Rollers c/w Tyre	1	1588-006
9	Roller Stub Shaft (one per roller)	1	1588-113
10	Connecting Rod Assembly	1	1588-474T
11	Vee – Belt	1	1279-106-***
12	Idler Pulley Assembly c/w Spring	1	1588-452T
13	Idler Pulley Tension Spring	1	1279-496
14	Idler Pulley Guide Assembly	1	1588-490
15	Drive Shaft and Pulley Assembly – Standard	1	1642-003
16	Motor Housing Base	1	1642-344
18	Front Cover – Less Heater	1	See calculator 1681-161
20	Motor Cover Gasket	1	1642-346
21	Main Frame Bolts	Each	H0008-015S
22	End Cover	Pair	1588-058*
25	Main Frame	1	See calculator 1681-161
27	Motor Housing Bolt	Each	H0006-020S
28	Pivot Block Securing Bolt	1	*NLO.25F-S
29	Gasket	1	1642-026
30	Arm Spring(s) - where fitted ‡	1 or 2	1279-157
31	Twin Tie- Bar	1	1588-303-***
32	Ball valve	1	1588-609
33	Motor - Pneumatic	1	1588-608

\*\*\* in the Part Number means length in mm.

### in the part number means spring pressure in lb/ft. Wynn determines this according to arm and blade dimensions, together with any window rake angle from the vertical. This value can also be obtained from the original order documentation. See Wynn Agent for more details.

‡ where required, extra spring pressure is obtained by the addition of 1 or 2 springs to the wiper arm. Where fitted, order 1 or 2 as required. Contact Wynn Agent for more details.

# 11 Type D MKII Single Spares Drawing

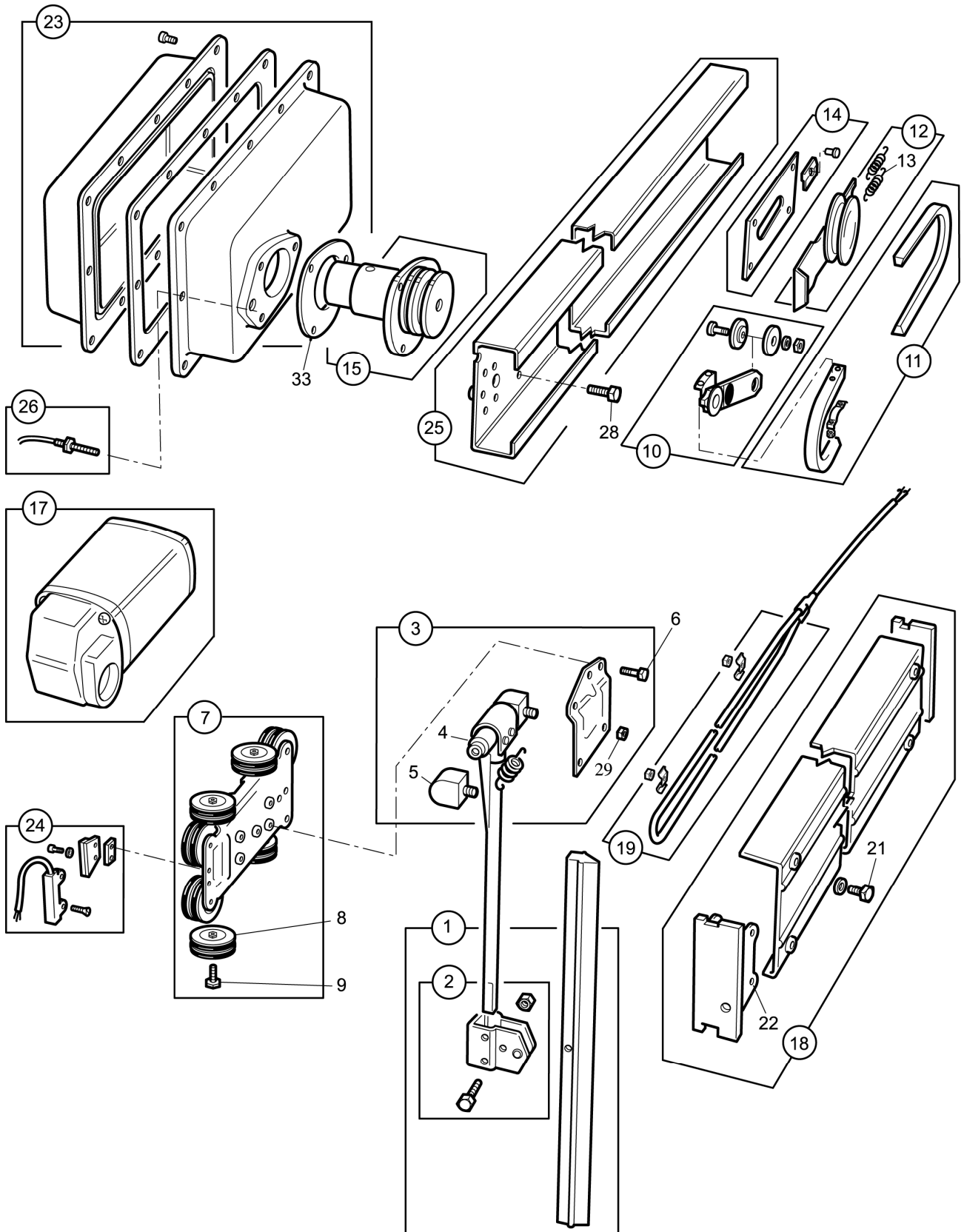

## 12 Type D MKII Twin Spares Drawing

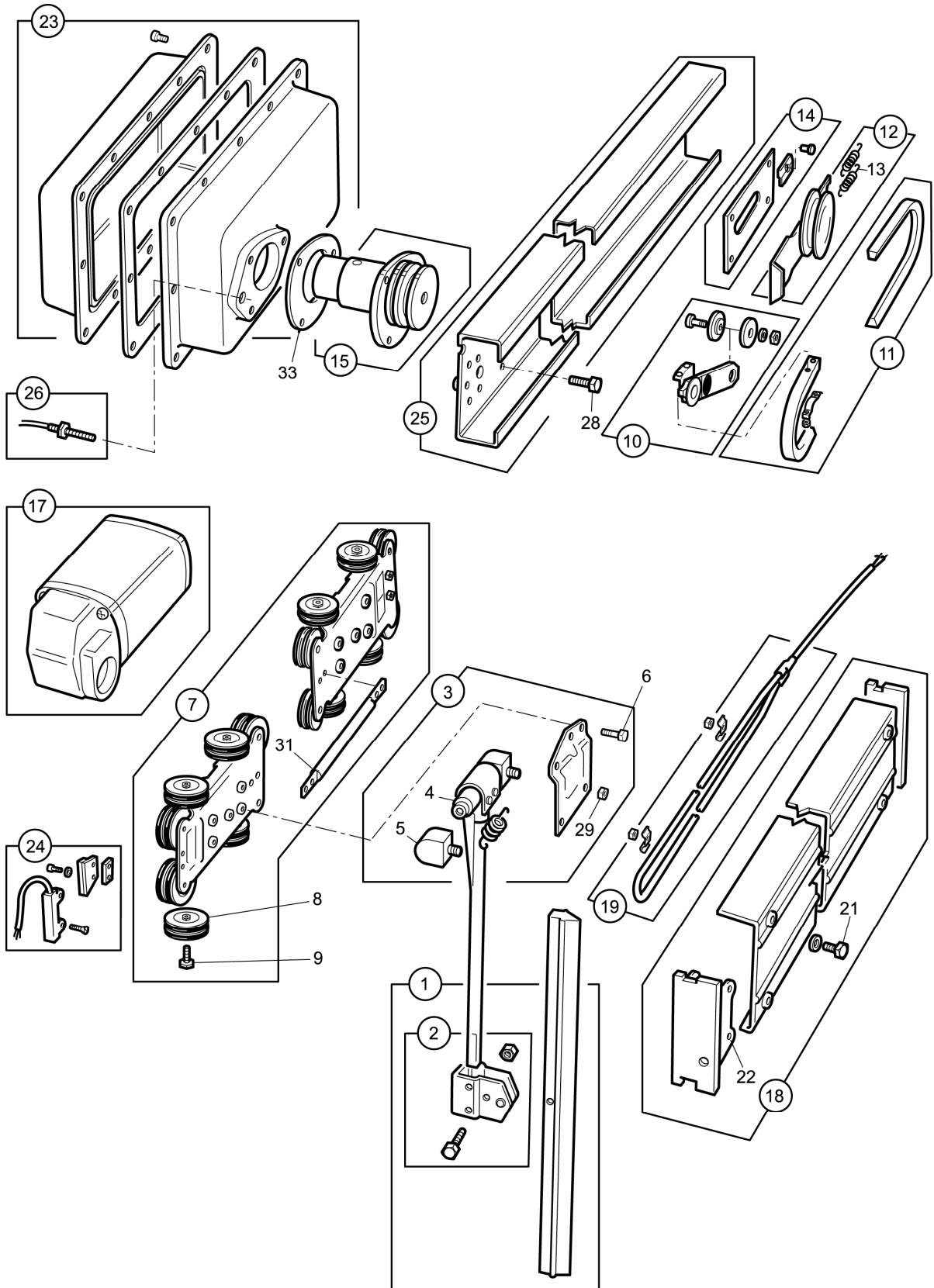





## **13 Documentation**

Whilst every effort is made to provide accurate information in good faith, no responsibility can be accepted by Wynn for inaccuracies and Wynn reserves the right to alter and amend specifications and designs without prior notice in line with our policy of continued improvement.

### **Spares Parts**

To enable technical troubleshooting and ordering of spare parts, this manual should be kept in a safe place on board. It is also advisable to keep one set of spare parts on board for emergency use. Please contact Wynn directly or your local distributor / service centre for all order requirements.

### **Maintenance Schedules**

Plan your maintenance work according to the schedule in this manual.

### **Our Commitment**

We are committed to a 10 year product support programme. This ensures that any spare part will be available for any wiper at least 10 years after its purchase. It is strongly recommended that only genuine replacement parts manufactured by WYNN be used. This will guarantee that only suitable materials have been used and will ensure interchangeability of parts.

### **Quality and Testing**

We are committed to the principles of Total Quality Management, ISO 9000. We manufacture our range of marine products to the highest standard and quality. We therefore maintain an ongoing schedule of product improvement and testing. To help us sustain such standards we maintain a salt-water test rig on which our products are taken, at random from the production line, and subjected to 3,000 hour continuous testing. We are sure you will receive many years trouble-free service from your Wynn product and hope you find this information pack comprehensive.

### **Guarantee**

All Wynn equipment is tested before despatch from our works. The Windscreen Wiper System supplied has a 1 year warranty period provided the installation of the system and the subsequent maintenance is in accordance with the installation/maintenance instructions.

We cannot accept any responsibility for the installation of equipment, or damage to the equipment during installation, or normal wear and tear. The guarantee is negated if the equipment is not installed strictly observing the instructions set out in this manual, or not maintained as specified.

The Wiper System is very reliable but to ensure its continued smooth running we recommend that the following guidelines are adhered to:-

### **Monthly**

- Check for wear on all parts subject to friction
- Visual inspection should be made of the blades to ensure that they are still in good condition and replace as soon as there are signs of wear or damage

### **Annually**

- It is recommended that the blades are changed every 12 months

After the Wiper System has been operating in severe weather conditions it is advisable to thoroughly check the unit for signs of wear or damage.

This warranty excludes the wiper blades which are a consumable item and any replacements that are detailed in the manual as part of any regular maintenance requirement.

This guarantee is expressly in lieu of all other guarantees expressed or implied and of all other obligations of liabilities on our part, and we neither assume nor authorise any other person to assume for us any other liability in connection with the sale of our equipment. Faulty equipment must be returned, carriage paid, to our works for examination. Any legal action must be settled in the English courts under English law.

A worldwide network of agents supports Wynn's Marine product range. For details of the nearest Wynn agent please contact our Head Office. Wynn Agents operate in the following countries.

Argentina, Australia, Brazil, Canada, Chile, China, Croatia, Denmark, Egypt, Finland, France, Germany, Greece, Hong Kong, Iceland, India, Israel, Italy, Japan, Korea, Netherlands, New Zealand, Norway, Oman, Peru, Poland, Portugal, Singapore, South Africa, Spain, Sweden, Taiwan, Turkey, Ukraine, U.S.A.



Wynn Marine Ltd

2-4 Merse Road, North Moons Moat, Redditch, Worcestershire B98 9HL, United Kingdom

Tel: +44 (0) 1527 61243, Fax: +44 (0) 1527 66836

Email: [info@wynn.co.uk](mailto:info@wynn.co.uk), website [www.wynn.co.uk](http://www.wynn.co.uk)