

## User Manual



**MetConnect THP**



**MetConnect One**

### Table of Contents

<b>1. Welcome</b>	<b>5</b>
1.1. Overview of Content	5
1.2. Description of Icons	5
1.3. General Notes	6
1.4. User Manual Revision History	6
<b>2. Product Overview</b>	<b>7</b>
2.1. MetConnect Product Range	7
2.2. MetConnect Specification	8
2.3. MetConnect Component Parts	8
2.4. MetConnect Standard Equipment	8
2.5. Downloadable Software	8
2.6. MetConnect Accessories	9
2.7. MetConnect CE, UKCA, FCC conformity	9
2.8. Right to change and revise	9
<b>3. Set-up MetConnect</b>	<b>10</b>
3.1. Introduction	10
3.2. Configurable features	10
3.3. MetSet Set-Up Software	11
3.4. Connect MetConnect to MetSet	12
3.5. Set-Up Communication Protocol	12
3.6. Set-up MetConnect integrated sensors	12
3.7. Set-up additional sensor inputs	12
<b>4. Install MetConnect</b>	<b>13</b>
4.1. Introduction	13
4.2. Select an appropriate site	13
4.2.1. Physical Location	13
4.2.2. Distance from the power supply and data collection system	13
4.2.3. EMC Interference	14
4.3. Prepare the equipment	14
4.3.1. Power and Communications Cable	14
4.3.2. Connector Pin Allocation	15
4.3.3. Power and Earthing	15
Power	15
Earthing	16
4.3.4. Connection of additional sensors	16
4.4. Install the MetConnect	17
4.4.1. Select Alignment	17
4.4.2. Install MetConnect on a Pipe or Pole	17
4.4.3. Install MetConnect to a Panel or Wall	18
4.4.4. Install Cable Strain Relief	18
4.4.5. Install Earthing	18

<b>5. Use MetConnect</b>	<b>19</b>
5.1. Introduction	19
5.2. MetConnect data	19
5.3. Status Codes	19
5.4. MetView software	19
5.5. Fault Finding	19
<b>6. Maintain MetConnect</b>	<b>20</b>
6.1. Introduction	20
6.2. Product Maintenance	20
6.2.1. General Maintenance	20
6.2.2. Wind Sensor	20
6.2.3. Pressure Sensor	21
6.2.4. Shield	21
6.2.5. Temperature and Humidity Sensor	21
6.2.6. MetConnect Mounting Bracket Plates, Bolts, Connectors and Cable Clamps	21
6.2.7. Cable clamps	21
6.2.8. Earthing	21
6.2.9. Additional Sensors	21
6.3. Calibration	21
6.3.1. Pressure Sensor	21
6.3.2. Other Gill Instruments Sensors	21
6.3.3. Additional Sensors	21
6.4. Fault Finding	22
6.5. Safe Mode	23
6.6. Product Repair	23
6.6.1. Minor Repairs	23
6.6.2. Major Repairs	23
6.7. Warranty Repairs	23

Appendix A - Technical Specification .....	24
Appendix B - MetConnect Connector Pin Allocation .....	27
Appendix C - Connecting Gill Anemometers to a MetConnect THP .....	28
Appendix D - MetConnect Default Set-up .....	32
Appendix E - MetConnect Safe Mode .....	33
Appendix F - MetSet Software.....	34
Appendix G - MetConnect ASCII Data Output .....	39
Appendix H - MetConnect MODBUS Data Output .....	41
Appendix I - MetConnect NMEA 0183 Data Output.....	44
Appendix J - MetConnect SDI-12 Data Output .....	46
Appendix K - Polled Mode Commands .....	51
Appendix L - MetView Software .....	52
Appendix M - MetConnect Status Codes .....	55
Appendix N - M12 to USB Configuration Cable Installation .....	57

### 1. Welcome

#### Welcome to the MetConnect user manual.

##### About this manual

This manual provides the information needed to get the best results from MetConnect. The most recent version of this manual is available at [gillinstruments.com](http://gillinstruments.com).

**Please read this manual before setting up and installing MetConnect.**



#### 1.1. Overview of Content

The manual is split into 6 chapters. Each chapter represents an activity in the use of the product. Additional detailed information is contained in the Appendices at the end of the manual.

- Chapter 1 explains how the manual is set out
- Chapter 2 provides a brief overview of the product
- Chapter 3 provides the information needed to set-up the product
- Chapter 4 provides the information needed to install the product
- Chapter 5 provides the information needed to use the product
- Chapter 6 provides guidance for product maintenance and fault finding

#### 1.2. Description of Icons

The following icons are used in this manual.

Icon	Description
	A note that is important and that should be observed
	Information or a recommendation to ensure best results
	The start of a set of instructions

### 1.3. General Notes



Before MetConnect is used for the first time it is essential to read and understand this manual. Please keep the manual safe for future reference.



Care should be taken with MetConnect at all times. The product should be transported to site in the box, and only removed when ready to install.



During installation MetConnect should be supported and care should be taken not to drop the product



Care should be taken when wiring the MetConnect to power and communications.



Maintenance should be limited to the procedures described in this manual. Additional maintenance or cleaning may damage the sensors.



No attempt should be made to open or repair any of the parts of the product (including the hub box, the wind sensor, the pressure sensor and the temperature and humidity sensor). Any attempt to open the hub box or any other part of the product will invalidate the warranty provided by Gill Instruments.

### 1.4. User Manual Revision History

Document Version	Release Date	Key Changes
0.82	25 Nov 2021	"Final" draft for Review
1	15 Dec 2021	First Release

### 2. Product Overview

The MetConnect Weather Station is designed to be simple to install, use and maintain. In addition to measuring a range of atmospheric parameters, the product supports the connection of additional user selected sensors. All measurement data is output as a single string and available on a range of communication protocols.

#### 2.1. MetConnect Product Range

The MetConnect product range is designed to:

- Provide high quality environmental measurements
- Allow connection of additional sensors
- Be easy to set up and install
- Be easy to maintain

The MetConnect product range includes two models

- MetConnect THP
- MetConnect One

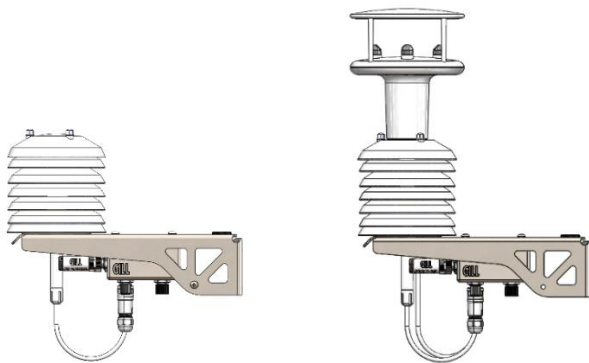

MetConnect THP

MetConnect One

The sensors included in each model are shown below.

	MetConnect THP	MetConnect One
Temperature	S	S
Humidity	S	S
Pressure	S	S
Wind speed and direction	C	S (integrated)
Analogue Sensor Input 1	C	C
Analogue Sensor Input 2	C	C
PRT	C	C
Rain	C	C

S = **Sensor supplied** as part of MetConnect model

C = **Connector** available for user supplied sensor

# MetConnect

## Professional Weather Station

### 2.2. MetConnect Specification

The MetConnect specification can be found in Appendix A (page 24) of this manual.

### 2.3. MetConnect Component Parts

MetConnect consists of a number of different parts. These parts may be referred to in this manual so it is important to understand their naming. The diagram below lists the key parts within the product.

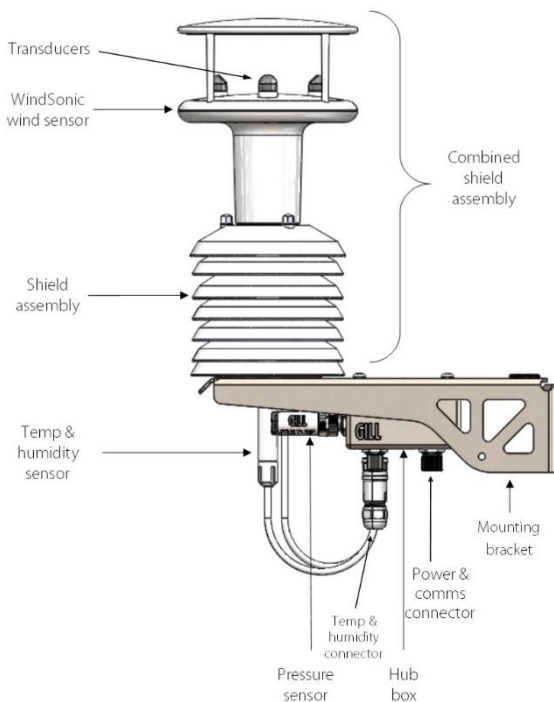

### 2.4. MetConnect Standard Equipment

MetConnect is supplied with:

- Bracket Mounting plates, bolts and nuts

Gill Instruments offer a range of accessories to support the MetConnect product, including cables, connectors and replacement sensors. A list of accessories is available at [gillinstruments.com](http://gillinstruments.com).

### 2.5. Downloadable Software

Two software packages are available to help customers use MetConnect.

- MetSet - this software can be used to set-up the product
- MetView - this software can be used to view the data provided by the product

Both software packages can be downloaded from [gillinstruments.com](http://gillinstruments.com).



### 2.6. MetConnect Accessories

A range of accessories is available to support MetConnect. A list of accessories is shown below.

More information, and the most up to date list of accessories can be found at [gillinstruments.com](http://gillinstruments.com).

Accessory	Gill Instruments Part Number
Connector, M12, 8 way, field wireable	1733-PK-002
Cable, for power and communications, 2m with M12, 8 way over moulded connector	1733-PK-012
Cable, for power and communications, 10m with M12, 8 way over moulded connector	1733-PK-013
Cable, for power and communications, 20m with M12, 8 way over moulded connector	1733-PK-014
Bracket Mounting Plate, replacement	1733-PK-022
Cable, M12 to USB, for MetConnect set-up	1733-PK-031
Sensor, replacement pressure sensor	1733-PK-040
Sensor, replacement temperature and humidity sensor	1733-PK-041
Heater Interface box for external anemometer	1733-PK-099

### 2.7. MetConnect CE, UKCA, FCC conformity

This product carries the CE and UKCA marks. A copy of the Declaration of Conformity can be downloaded from [gillinstruments.com](http://gillinstruments.com).

Note: This equipment has been tested and found to comply with the limits for a Class A digital device, pursuant to part 15 of the FCC Rules. These limits are designed to provide reasonable protection against harmful interference when the equipment is operated in a commercial environment. This equipment generates, uses, and can radiate radio frequency energy and, if not installed and used in accordance with the instruction manual, may cause harmful interference to radio communications. Operation of this equipment in a residential area is likely to cause harmful interference in which case the user will be required to correct the interference at his own expense.

### 2.8. Right to change and revise

Gill Instruments reserve the right to change or revise the product without notice or the obligation to notify any person or organisation of such change or revision.

Gill Instruments reserve the right to change or revise the information supplied in this manual without notice or the obligation to notify any person or organisation of such change or revision.

The reproduction and distribution of the documentation and software supplied with this product and the use of its contents is subject to written authorization from Gill Instruments.

### 3. Set-up MetConnect

#### 3.1. Introduction

MetConnect is designed as a flexible product able to support a range of user definable options. This chapter provides:

- An overview of the configurable features
- An introduction to the MetSet set-up software
- Information about communication protocol options
- Information about connecting additional sensors
- An explanation about Safe Mode

#### 3.2. Configurable features

MetConnect is designed to allow the following features to be configured:

- Measurement output protocol, e.g. RS232, RS422, RS485, SDI-12
- Measurement output frequency e.g. 1/sec, polled
- Measurement units e.g. m/s, mph, kph, knots
- The data, and the order of data, contained in the output message
- Measurement of additional parameters using the available connectors
  - Two analogue input type (0-5v, 4-20mA) can be configured
  - The scaling of the tipping bucket rain gauge



It is recommended that MetConnect is set-up before installation to enable the unit to be tested and the set-up confirmed.



It is recommended that the MetSet software package is used to set-up MetConnect. More details of MetSet can be found in the next sections of this manual.

**The default set-up can be found in Appendix D (page 32). It is recommended that this information is reviewed before continuing.**

### 3.3. MetSet Set-Up Software

A free to download software package called MetSet is available to enable MetConnect to be set-up.

MetSet is compatible with Windows 7 and Windows 10.

MetSet software can be downloaded from [gillinstruments.com](http://gillinstruments.com).

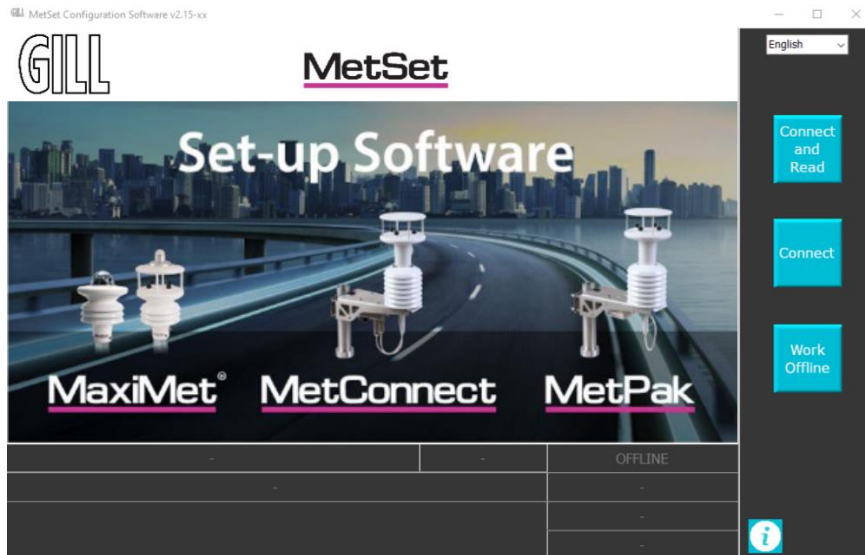

MetSet can be used to create a user specific set-up that can be loaded onto MetConnect.

To use MetSet:

1. Connect MetConnect to the PC running MetSet
2. Open MetSet on the PC
3. Click on the **CONNECT AND READ** button
4. Allow MetSet to identify the appropriate COM port
5. Select the appropriate tab and make the required change (see Appendix F, page 34, for details)
6. Click on the **SAVE SETUP** button
7. Return to step 5 to change additional settings
8. When all required setting have been changed click on the **WRITE SETTINGS** button
9. Measurement changes (measurement units, etc.) will be applied immediately
10. Certain changes will require the Metconnect to be power cycled, eg protocol or Baud rate changes.



As shown above, it is recommended that the **SAVE SETUP** button is used to save the set-up before writing it to MetConnect. This will ensure that a copy of the set-up is available if it needs to be checked, or if the set-up needs to be written to another MetConnect.

### 3.4. Connect MetConnect to MetSet

MetConnect can be connected to MetSet using

- The USB to MetConnect cable, available as an accessory from Gill Instruments (Gill part no. 1733-PK-031)
- The power and communications cable, connected to a PC via an RS232 connector or similar.



The USB to MetConnect cable can power the MetConnect unit for configuration but **should not be used** to power the MetConnect in normal operation.



The USB to MetConnect cable should only be connected to the power and communications connector and **should not be connected** to any of the sensor connectors.

### 3.5. Set-Up Communication Protocol

The default communications set-up for MetConnect is:

- RS232
- ASCII data output
- 19200 Baud rate
- Continuous 1Hz measurement output rate
- NODE ID = Q
- ASCII Set Up = CRLF
- Echo = On

The communication set-up can be changed to support:

- Interfaces – RS323, RS422, RS485, SDI-12
- Protocols – ASCII, MODBUS, NMEA 0183
- Baud rate – 4800, 9600, 19200, 38400, 57600
- Data output rate – 1 per second, 1 per 2 seconds, 1 per 4 seconds, polled
- NODE ID, ASCII set up and Echo can also be changed.

Information on how to use MetSet to change the communications set-up is contained in Appendix F (page 34).

### 3.6. Set-up MetConnect integrated sensors

The integrated sensors can be set-up to meet the requirements of a specific application. For each sensor:

- The sensor data can be switched ON or OFF
- The units of measurement can be selected

MetSet can be used to set-up the measurement data supplied by each integrated sensor.

Information on how to use MetSet to change the standard sensor set-up is contained in Appendix F (page 34).

### 3.7. Set-up additional sensor inputs

MetConnect is designed to allow additional sensors to be connected. The following sensor inputs are supported:

- Analogue voltage 0-5v
- Analogue current 4-20mA
- Contact closure/tipping bucket
- PRT Temperature sensor input

MetSet can be used to set-up and scale the data from these sensors.

Information on how to use MetSet to change the standard sensor set-up is contained in Appendix F (page 34).

### 4. Install MetConnect

#### 4.1. Introduction

To install MetConnect, it is recommended that the following steps are taken:

- Select an appropriate site
- Prepare the equipment
- Install the unit

#### 4.2. Select an appropriate site

When selecting a site three attributes need to be considered:

- Physical location and obstructions
- Distance from the power supply and data collection system
- EMC interference

##### 4.2.1. Physical Location

To achieve the most consistent measurements MetConnect should be located according to the World Meteorological Organisation (WMO) guidelines. More information about these guidelines can be found at [www.wmo.int](http://www.wmo.int).

In summary, allowing for the specific MetConnect model variant and installation site restrictions, it is recommended that:

- The wind sensor should be located 10m above ground and at a reasonable distance from buildings and trees. Ideally the reasonable distance should be 10 times the height of the building or tree.
- The MetConnect Hub Box and associated temperature, humidity and pressure sensors should be located approximately 2m above the ground.
- Additional, user selected sensors should be located according to the manufacturer's or WMO guidance.

When selecting the site, North alignment should be considered. The wind measurement includes direction information based on the north marker included in the wind sensor design. Measurements can be adjusted by entering the offset between north and the alignment of the north marker into MetConnect using MetSet.

##### 4.2.2. Distance from the power supply and data collection system

The site should be close enough to power and communications to enable correct working.

- The maximum cable lengths for power will depend on the voltage of the power supply used, the current drawn by MetConnect (including any additional sensors) and the resistance of the cable selected. Make sure that the power available to MetConnect is sufficient to ensure correct operation. More information about the power requirements can be found in section 4.3.3.
- The maximum cable lengths for communications will depend on the communications protocol selected. It is recommended that the following maximum cable lengths are used:
  - RS232 - 6.5m
  - RS422 - 1000m
  - RS485 - 1000m
  - SDI-12 - 90m

### 4.2.3. EMC Interference

The site selected should be away from strong sources of electromagnetic noise.

The product has been tested and certified to work in normal conditions. High levels of electromagnetic noise may affect the performance of the product. To ensure accurate operation the following guidelines are provided:

- Do not mount the product in close proximity of a high power radar or radio transmitter. In particular:
  - Avoid mounting the product in the plane of any radar scanner - a vertical separation of at least 2m is recommended.
  - Avoid mounting the product within:
    - 1m of a VHF/IMM transmitter
    - 5m of a MF/HF transmitter
    - 5m of a Satcom transmitter, and avoid line of sight
- Ensure the product is correctly earthed in accordance with section 4.4.5 of this manual
- Ensure earth loops are not created
- Use cables recommended in accordance with this manual
- Do not exceed the maximum cable lengths recommended in this manual
- Ensure the power supply operates to the MetConnect specification at all times

### 4.3. Prepare the equipment

To install the product the following additional equipment will be required:

- Power and Communications Cable
- Power and Earthing
- Data Communications
- Additional Sensors

#### 4.3.1. Power and Communications Cable

Gill Instruments can supply cable suitable for connecting to MetConnect to power and data collection systems. It is recommended that any cable used meets the specification shown below.

The maximum length of the cable will be set by the chosen communications protocol.

Cable Feature	Recommendation	
Wire Size	24 AWG	
Strand Size	7 x 32 AWG	
Pairing	Twisted pair with drain wire	
Screening	Screened with aluminium tape	
Outer Diameter	6-8mm	
Number of pairs required and maximum cable length	RS232	3 pairs, max. length = 6.5m
	RS422	4 pairs, max. length = 1000m
	RS485	4 pairs, max. length = 1000m
	SDI-12	2 pairs, max. length = 90m

### 4.3.2. Connector Pin Allocation

The pin allocation for the power and communications connector is shown below. It is recommended that:

- Any cable wires not used should be isolated and grounded at the terminating equipment/user end.
  - Signal ground should be used in conjunction with RS422 TX/RX lines in order to improve noise immunity.
- \*NOTE:** Cable colours below represent Gill supplied cable.

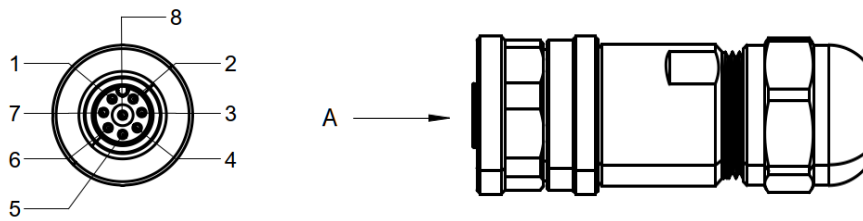

VIEW ON ARROW A

Pin	Wire Colour	RS-232	RS-422	RS-485	SDI-12
1	White	Power Ground	Power Ground	Power Ground	Power Ground
2	Brown	Rx-	Rx-	Rx-	-
3	Green	-	Tx+	Tx+	-
4	Yellow	Tx-	Tx-	Tx-	-
5	Grey	-	Rx+	Rx+	-
6	Pink	Power (V+)	Power (V+)	Power (V+)	Power (V+)
7	Blue	Signal Ground	Signal Ground	Signal Ground	Signal Ground
8	Red	-	-	-	SDI-12 Signal

### 4.3.3. Power and Earthing

It is recommended that the following power and earthing requirements are followed to ensure consistent performance of the unit.

#### Power

The power required to be supplied **at the unit** is shown below. Any voltage drop between the power supply and the unit should be considered.

Model	Supply Voltage	Average current (12V dc power)	Peak current (12V dc power)	Power
MetConnect THP	5-30v at the unit (9.6-16V dc for SDI-12)	<50mA	<100mA	< 1 watt
MetConnect One	5-30v at the unit (9.6-16V dc for SDI-12)	<42mA	<100mA	< 1 watt

**\*NOTE:** Above values are dependent on the sensors used. Additional sensors may have different supply voltages.

### Earthing

To ensure correct operation the MetConnect bracket should be earthed using the earth points on the bracket. A minimum of 6mm<sup>2</sup> copper wire should be used for this purpose.

In addition, Gill recommend that for maximum protection from lightning, a separate lightning rod system is used to protect the system.

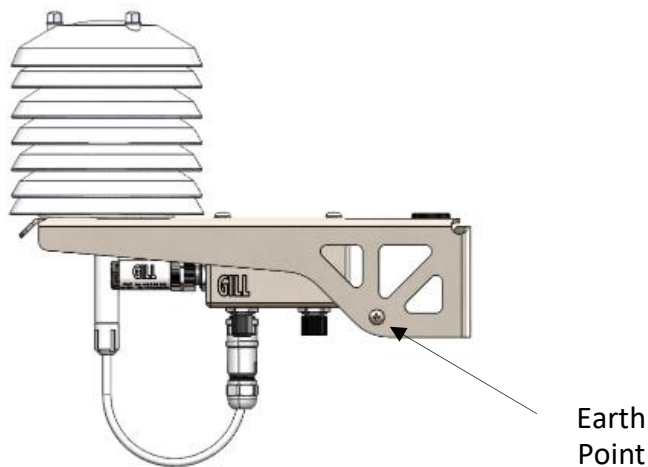

### 4.3.4. Connection of additional sensors

Additional sensors can be connected to MetConnect via the connectors on the hub box. The pin allocation of the additional sensor connectors is shown in Appendix B (page 27).

For additional sensors, manufacturers' recommendations for cable specification and length should be followed.



### 4.4. Install the MetConnect

To install the MetConnect the steps below should be followed:

- Select alignment method
- Install the MetConnect
- Install Cable Strain Relief
- Install Earthing

#### 4.4.1. Select Alignment

For accurate wind direction data, the product must be aligned to a reference point. This can be done in two ways:

- Alignment to North  
To align the product to North, use the North Alignment marker located on the wind sensor.  
Note: If necessary, the shield assembly can be unbolted from the bracket and rotated to assist alignment.

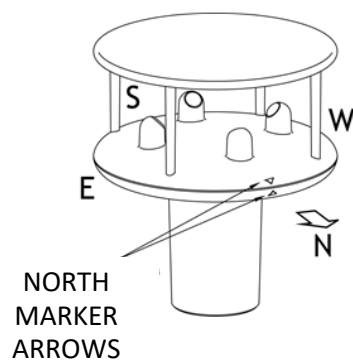

- Alignment to other directions  
If it is not possible to align the product using the North Alignment marker, then the direction of the marker should be measured and loaded into the product using MetSet. (e.g. if the north marker is pointing East then the angle is 90°, if the north marker is pointing West then the angle is 270°).

#### 4.4.2. Install MetConnect on a Pipe or Pole

The MetConnect unit can be mounted on a pole with diameter 30mm-58mm (1.2"-2.3"). The bracket must be secured using the bracket mounting plates supplied. The clamp nuts should be tightened to a torque of 3Nm.

Mounting without bracket mounting plates may damage the bracket.

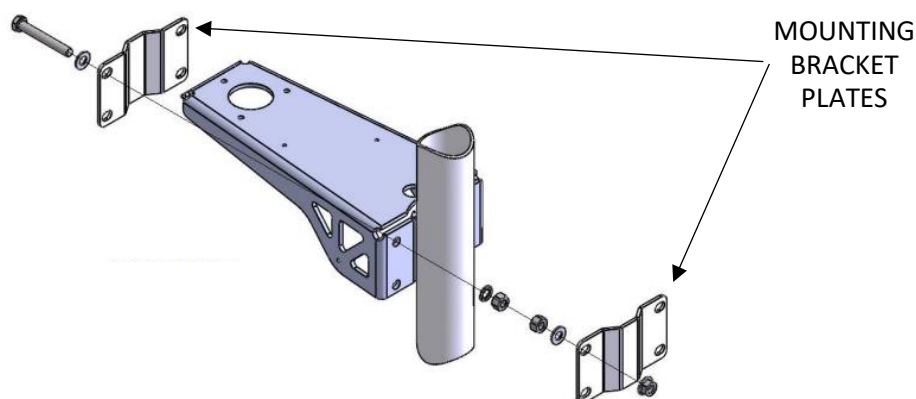

### 4.4.3. Install MetConnect to a Panel or Wall

The MetConnect bracket can be used to mount the product on a vertical surface such as a panel or a wall. MetConnect should be installed with a mounting bracket plate and secured using four bolts. Details of the required bolt locations are shown below.

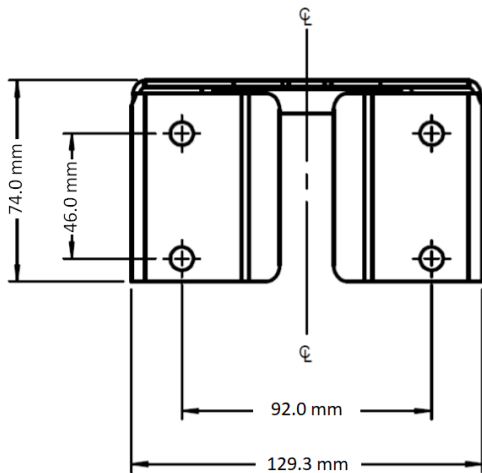

### 4.4.4. Install Cable Strain Relief

Once MetConnect has been secured in place, all cables should be secured:

- With cable clamps or equivalent such that the hub box connector does not support the cable weight.
- Away from the mounting bolts to prevent chafing of the cable.
- At appropriate points along the cable run/down the pole. If possible, place the cable away from the external environment, e.g. through the mounting pole.

### 4.4.5. Install Earthing

The MetConnect unit should be earthed using the bracket earthing point. A minimum of 6mm<sup>2</sup> copper wire should be used.

To ensure correct operation and for maximum protection from lightning, a separate lightning rod system is recommended to protect the system.

### 5. Use MetConnect

#### 5.1. Introduction

Once installed, MetConnect will provide data in the format selected during the set-up process described in Chapter 3. This chapter provides information on:

- The data provided by MetConnect
- The status codes provided by MetConnect
- The MetView software package
- How to fault find with MetConnect

#### 5.2. MetConnect data

The records provided by MetConnect contains two types of data:

- Measurement data - this contains the measurements taken by the sensors
- Status data - this contains information about the status of the sensors

MetConnect can be connected using a range of communication protocols. More information about the protocols available can be found in section 3.5 and in the appendices.

#### 5.3. Status Codes

MetConnect is designed to provide a measurement status code with each measurement. The status code indicates if a sensor has experienced any difficulty in making a measurement. The status code can be included in the data reported by the unit.



In normal operation the following status codes indicate that no warning messages are present:

Output mode	"No warning" status code
ASCII/MODBUS/SDI-12 output	0
NMEA output	A

A list of warning status codes can be found in Appendix M (page 55).

#### 5.4. MetView software

Gill Instruments provide the MetView software package that can be used to view and log the data provided by MetConnect, however the output of the MetConnect can be viewed/logged by other packages/systems.

MetView is compatible with Windows 7 and Windows 10.

MetView can be downloaded from: [www.gillinstruments.com/main/software.html](http://www.gillinstruments.com/main/software.html).

More information about how to use MetView can be found in Appendix L (page 52).

#### 5.5. Fault Finding

If any difficulty is experienced when using MetConnect, a fault finding guide can be found in section 6.4

### 6. Maintain MetConnect

#### 6.1. Introduction

MetConnect does not normally require regular maintenance. However, to help ensure the best results from the product this chapter provides information on:

- Product Maintenance
- Product Calibration
- Fault Finding
- Safe Mode
- Product Repair

#### 6.2. Product Maintenance

##### 6.2.1. General Maintenance

Although the MetConnect requires limited general maintenance, Gill recommend that the product be kept clear of a build-up of contaminants, and that ice and snow be allowed to defrost naturally:



If there is a build-up of deposits on any of the MetConnect parts, these should be cleaned using a cloth, moistened with mild detergent. Solvents should not be used and care should be taken to avoid scratching.



When maintaining the MetConnect, do not use high pressure sprays or high temperature/stream cleaning.



If any part of the MetConnect is exposed to ice or snow, the unit should be allowed to defrost naturally. The ice or snow should not be removed with a tool, or by additional heat being applied.

MetConnect Part	Recommended Maintenance Summary
Wind Sensor	Inspect every 12-24 months depending on environment
Pressure Sensor	Recommend replacement every 24 months, depending on environment
Temperature and Humidity Sensor	Recommend replacement every 24 months, depending on environment
Shields	Inspect, and clean every 24 months depending on environment
MetConnect Mounting Bracket Plate Clamp and Cable Clamps	Inspect to ensure secure fixing every 24 months
Earthing point and Cable	Inspect to ensure effective electrical contact every 24 months
Additional Sensors	Inspect, clean and replace in accordance with manufacturer's recommendations

##### 6.2.2. Wind Sensor

The wind sensor should not require any maintenance under normal circumstances. When completing general maintenance, care should be taken with the black transducers. A reduction in the wind sensor performance may occur if the transducers are damaged. Damage of the transducers may result in a reduction in performance.

### 6.2.3. Pressure Sensor

The pressure sensor includes a small venting filter which may become blocked in some environments. To maintain the most accurate measurements it is recommended that the sensor be replaced every 24 months. A spare sensor can be purchased as a field replaceable unit.

### 6.2.4. Shield

The shield assembly should not require any maintenance under normal circumstances. When convenient the shield should be cleaned as described in General Maintenance.

### 6.2.5. Temperature and Humidity Sensor

The temperature and humidity sensor should not require maintenance in normal environments. To maintain the most accurate measurements it is recommended that the sensor be replaced every 24 months. A spare sensor can be purchased as a field replaceable unit.

### 6.2.6. MetConnect Mounting Bracket Plates, Bolts, Connectors and Cable Clamps

It is recommended that the MetConnect mounting bracket, mounting bolt torque, connector fixings and cable clamps are checked periodically. It is recommended that these checks are carried out when other checks are scheduled.

### 6.2.7. Cable clamps

It is recommended that the cable clamps or alternative fixings of the cables should be checked every 24 months.

### 6.2.8. Earthing

It is recommended that the earthing of the MetConnect unit should be checked every 24 months to ensure that a good electrical contact is maintained between MetConnect and an appropriate earth.

### 6.2.9. Additional Sensors

Any additional sensors connected to MetConnect should be inspected, cleaned, maintained and replaced in line with the appropriate manufacturer's instructions.

## 6.3. Calibration

### 6.3.1. Pressure Sensor

As is common with pressure sensors, the sensor calibration may drift by up to 0.3hPa per year. To maintain the most accurate measurements it is recommended that the sensor is recalibrated or replaced every 24 months.

### 6.3.2. Other Gill Instruments Sensors

All other MetConnect sensors should not require calibration under normal circumstances.

### 6.3.3. Additional Sensors

Any additional sensors connected to the MetConnect calibrated in line with the appropriate manufacturer's instructions.

### 6.4. Fault Finding

The MetConnect data output contains a status code to indicate the status of the unit and sensors. There may be a fault with the unit if:

- a status code occurs regularly, or
- any of the symptoms listed below are seen

If the solutions below do not clear the fault, please contact Gill Instruments Technical Support. The contact details for Gill Instruments Technical support can be found at [www.gillinstruments.com](http://www.gillinstruments.com).

Symptom	Solution
No output	<ul style="list-style-type: none"> <li>• Check DC power to MetConnect, cable and connections.</li> <li>• Check communications settings of the MetConnect and host system match, including correct host system Com port.</li> <li>• Check that the unit is in Continuous mode.</li> <li>• If appropriate use Safe Mode to attempt to obtain communication with the MetConnect (see section 6.5).</li> </ul>
Corrupted output	<ul style="list-style-type: none"> <li>• Check data for status codes. See Appendix M (page 55).</li> <li>• Check that the communication settings of the MetConnect and host system match. If necessary, return the MetConnect to RS232 using Safe Mode as described in section 6.5.</li> <li>• Try a slower baud rate.</li> <li>• Check cable lengths do not exceed the recommendation in section 4.3.</li> <li>• Check the cable type meets the recommendation in section 4.3.</li> <li>• Check for sources of external signal interference. Guidance is provided in section 4.2.</li> </ul>
One way communication	<ul style="list-style-type: none"> <li>• Check that the wiring between the MetConnect and the host system is in accordance with section 4.3.</li> </ul>
Unexpected Temperature or Dewpoint readings	<ul style="list-style-type: none"> <li>• Check data for status codes. See Appendix M (page 55).</li> <li>• Check the Temperature and Dewpoint units of measure (C, F, K) settings are correct on power up.</li> <li>• Check the Temperature and Humidity sensor connections are secure.</li> <li>• Check the shields are clean and the space between the shields allows for air to flow.</li> </ul>
Unexpected Wind readings	<ul style="list-style-type: none"> <li>• Check data for status codes. See Appendix M (page 55).</li> <li>• Check that the Wind Sensor units of measure (m/s, knots, kph, ft/min, mph) settings are correct on power up.</li> <li>• Check the wind sensor connections are secure.</li> <li>• Check the wind sensor for signs of debris or material that might block air flowing freely.</li> </ul>

Unexpected Pressure Readings	<ul style="list-style-type: none"><li>• Check data for status codes. See Appendix M (page 55).</li><li>• Check units of measure are set correctly.</li><li>• Check the Pressure sensor connections are secure.</li><li>• Visually inspect the pressure sensor for signs of debris, particularly the hexagonal molding on the end of the sensor assembly.</li><li>• Check when the pressure sensor was last replaced and replace if required</li></ul>
Status code not 00 or A	<ul style="list-style-type: none"><li>• Status codes 00 and A indicate the unit is working normally.</li><li>• Other status codes indicate that the measurement data that includes the status code may be unreliable.</li><li>• For more information about individual status codes see Appendix M (page 55).</li></ul>

### 6.5. Safe Mode

If the unit will not communicate, or the communication protocol settings are not known, then communications with the unit can be established using Safe Mode. Details of how to use Safe Mode can be found in Appendix E (page 33).

### 6.6. Product Repair

If the unit is damaged, a range of spare parts can be supplied by your local distributor or directly from Gill Instruments.

#### 6.6.1. Minor Repairs

Gill Instruments offer a range of replacement parts and sensors that can be installed by the user. A list of these parts, and their part numbers, is available on [gillinstruments.com](http://gillinstruments.com).

#### 6.6.2. Major Repairs

If the unit is more seriously damaged it can be returned for repair via a local distributor or directly to Gill Instruments.

The unit should be carefully packed in the original packaging or similar packaging to avoid any further damage. Where possible, a description of the fault, and a list of any fault codes seen, should be included.

Contact details to return a unit to Gill Instruments can be found at [gillinstruments.com](http://gillinstruments.com).

### 6.7. Warranty Repairs

If the unit experiences issues during the warranty period, the unit should be returned to Gill Instruments together with a copy of the original invoice.

The unit should be carefully packed in the original packaging or similar packaging to avoid any further damage. Where possible, a description of the fault, and a list of any fault codes seen, should be included.

Instructions on how to return a unit to Gill Instruments can be found at [gillinstruments.com](http://gillinstruments.com).

### Appendix A - Technical Specification

Wind Measurement	
Parameters	Polar Wind Speed & Direction or U and V Vectors
Wind Speed	
<b>* Values are dependent on anemometer being used</b>	
Range	0 to 60m/s
Accuracy	2% RMS at 12m/s
Resolution	0.01m/s
Threshold	0.01m/s
Units of Measurement	m/s, knots, mph, kph, ft/min
Wind Direction	
Range	0-359 Degrees
Accuracy	+/-3° at 12m/s
Resolution	1°

Air Temperature	
Range	-35°C to +70°C
Accuracy	±0.2°C (-35°C to +50°C)
Resolution	0.1°C
Units of Measure	°C or °F

Relative Humidity	
Range	0-100%
Accuracy	±1.5% RH @ 25°C (0-80%RH) Typical 2% (-35°C to 70°C, 0-100%RH)
Resolution	1%
Units of Measure	% RH

Dew Point	
Resolution	0.1°C
Accuracy	±0.2°C (23°C ambient temperature @ 20°C dew point)
Units of Measure	°C or °F

Barometric Pressure	
Range	600 to 1100hPa
Accuracy	±0.5hPa Typical (0°C to 50°C)
Resolution	0.1hPa
Units of Measure	hPa, mbar, mmHg, InHg



Additional Sensor Inputs	
Analogue 1 (AN1) Analogue 2 (AN2)	Power available to sensor: 5V dc up to 50mA supplied to all sensors Voltage input: 0 to 5V (input impedance 330k ohm) or Current input: 4 to 20mA (input impedance 47 ohms) 12 bit resolution with an accuracy of $\pm 0.1\%$ of full scale reading
PRT	4 wire PRT, Pt100 conforms to IEC 60751
Rain Input (contact closure)	Minimum contact close duration: 1.4mS. Minimum time between closures: 11mS. Maximum resistance on contact closure: 1k ohm. Tip size scalable 0.1 to 10mm/tip Units of measurement: mm, inches

Outputs	
Digital Outputs	RS232, RS422, RS485 (2 wire point to point) or SDI-12. (RS232 point to point and RS485 2 wire networkable – MODBUS RTU/ASCII)
Baud Rates	1200 (SDI-12), 4800-57600 (ASCII RS232, RS422, *RS485) 9600-19200 (MODBUS RTU/ASCII)
Protocols	ASCII, SDI-12 V1.3, NMEA 0183 MODBUS RTU/ASCII
Data Output	1 reading per second (1 Hz), 1 reading per 2 seconds, 1 reading per 4 seconds or Polled Mode
MetConnect Status	Status codes provided within the data message string
<b>* RS485 2 wire point to point only.</b>	

Power Supply	
Input voltage	5v to 30v dc
Current at 12v	MetConnect THP: <70mA average, <100mA peak MetConnect One: <70mA average, <100mA peak
<b>*Sensor dependent</b>	

Environmental MetConnect Range	
Protection Class	IP66 & 67: Hub Box and pressure sensor IP66: Wind sensor IP66: Temperature & humidity sensor
EMC	BS EN 61326
Operating Temperature	-35°C to +70°C
Storage Temperature	-40°C to +70°C
Humidity	0 to 100%
RoHS Compliant	Yes

Mechanical MetConnect Range	
External Construction	Bracket and Hub Box: Stainless Steel 316 Shields: Polycarbonate Wind Sensor: UV Stabilised white thermoplastic
Fittings	Bracket Plates: Stainless Steel 316 Nuts & Bolts: Stainless Steel 316
Overall Dimensions (excluding bracket clamp)	MetConnect THP: 284mm x 287mm x 129mm MetConnect One: 440mm x 298mm x 142mm
Weight	MetConnect THP: 2.6kg MetConnect One: 3.0kg

Software	
MetSet	Free PC Software to set-up MetConnect
MetView	Free PC Software to view and log MetConnect data

### Appendix B - MetConnect Connector Pin Allocation

MetConnect has been designed with three connectors (Analog 1/Rain, Analog 2/Rain, PRT/Rain) to allow the use of additional sensors. The location of these connectors on the MetConnect hub box is shown below.

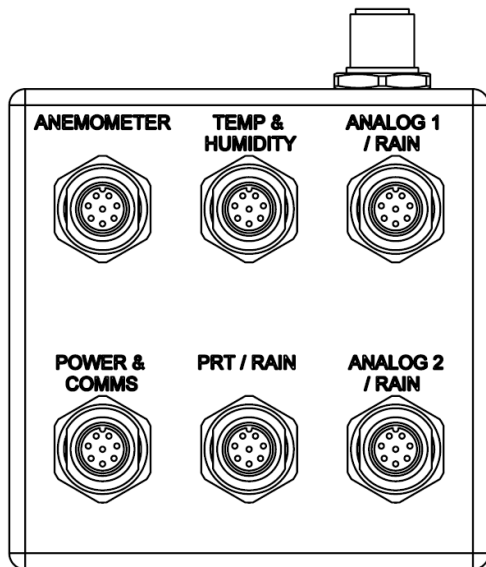

All MetConnect connectors are M12, 8 pin. The pin allocation of each of the connectors is shown below.

**\*NOTE:** Cable colours below represent Gill supplied cable.

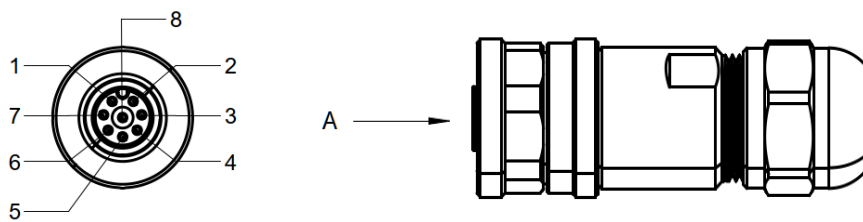

VIEW ON ARROW A

Pin	Cable	Analog 1/Rain	Analog 2/Rain	PRT/Rain
1	White	Power Ground/ Analogue Ground	Power Ground/ Analogue Ground	Power Ground
2	Brown	-	-	PRT +ve
3	Green	Current Measure	Current Measure	PRT -ve sense
4	Yellow	-	-	PRT -ve
5	Grey	Voltage Measure	Voltage Measure	PRT +ve sense
6	Pink	Power (V+)	Power (V+)	-
7	Blue	Rain Ref Ground	Rain Ref Ground	Rain Ref Ground
8	Red	Rain Signal	Rain Signal	Rain Signal

### Appendix C - Connecting Gill Anemometers to a MetConnect THP

MetConnect THP is designed to connect to a remote Gill anemometer. The anemometer must be from the compatible list of sensors below

#### Compatible Wind Speed and Direction Sensors

In order to connect a Gill Instruments anemometer to the MetConnect THP. A list of compatible sensors is shown below:

1405-PK-038	WindSonic Option 2 Black
1405-PK-072	WindSonic Option 2 White
1405-PK-200	WindSonic M Heated
1405-PK-300	WindSonic M Unheated
1405-PK-420	WindSonic 75 Option 2 Black
1390-65-B-X1X	WindObserver 65
1390-70-B-X1X	WindObserver 70
1390-75-B-X1X	WindObserver 75
1390-90-B-X1X	WindObserver 90
1590-PK-020	WindMaster
1561-PK-020	WindMaster Pro
1590-PK-130	WindMaster RA

#### Distance

The MetConnect THP communicates with the anemometer via RS422 serial communication. The RS422 serial protocol supports a maximum cable length of 1km. Gill recommend that an appropriate low resistance, screen cable be used for connecting the anemometer to the MetConnect.

Recommended cables and Gill part numbers can be found in the relevant Gill anemometer manual.

#### Heating

Note: If the anemometer is heated, a Heater Power Interface Box (Gill Part Number 1733-PK-099) is required.

Gill recommend that the heater Power Supply (including any junction boxes) should be no more than 10m from the anemometer to minimize power loss in the cable.

#### Connection, Configuration & Orientation

The anemometer must be configured specifically for use with the MetConnect THP prior to integrating with the station and connected as shown in the wiring diagrams included on the following pages. Please note that each model features a north alignment marker, this can be used to align the anemometer to compass north or another reference as necessary.

### WindSonic

#### WindSonic Connection Details

Function	MetConnect Pin	Heater Power Supply	WindSonic Pin	WindSonic M Non Heated	WindSonic M Heated
Sig Gnd	7	-	1	-	-
Supply +	6	-	2	2	2
Supply -	1	-	3	3	3
RS422+ input	5	-	4	4	4
RS422- input	2	-	5	5	5
RS422+ output	3	-	6	6	6
RS422- output	4	-	7	7	7
Screen shield	Connector body	-	Cut off wire at sleeve	1	1
Heater Supply +ve	-	Heater Supply +ve	-	-	8
Heater Supply -ve	-	Heater Supply -ve	-	-	9



#### WindSonic Configuration Settings

Gill Part Number	WindSonic Model	WindSonic Configuration Settings
1405-PK-038	WindSonic Option 2 Black	M4,U1,O1,L1,P1,B4,H2,NQ,F1,E2,T1,S4,C2,G0,K0,
1405-PK-072	WindSonic Option 2 White	
1405-PK-420	WindSonic 75 Option 2 Black	
1405-PK-200	WindSonic Metal Heated	
1405-PK-300	WindSonic Metal Unheated	

#### WindSonic Orientation - North Marker and UV Wind Components

North is indicated as shown on the drawing below:

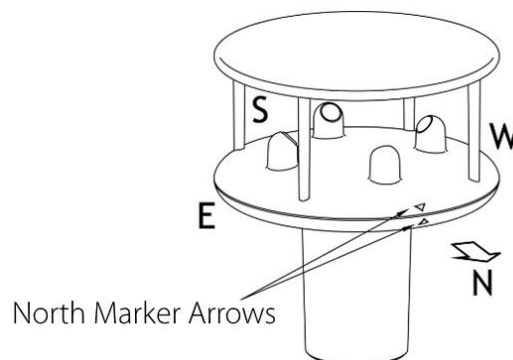

### WindObserver

#### WindObserver Connection Details

Function	MetConnect Pin	Heater Power Supply	WindObserver 65 Connector Pin	WindObserver 70, 75 & 90 Connector Pin
Sig Gnd	7	-	M	M
Supply +	6	-	R	R
Supply -	1	-	D	D
RS422+ input	5	-	P	P
RS422- input	2	-	C	C
RS422+ output	3	-	U	U
RS422- output	4	-	V	V
Screen shield	-	-	Cable Screen/Drain Wires	Cable Screen/Drain Wires
Heater Supply +ve	-	Heater Supply +ve	A	A, E & H
Heater Supply -ve	-	Heater Supply -ve	B	B, F & G



#### WindObserver Configuration Settings

Gill Part Number	WindObserver Model	WindObserver Configuration Settings
1390-65-B-11X	Unheated WindObserver 65	A0,B4,C1,E1,F1,G0000,H1,J1,K1,L1,M4,NQ,O1,P1,T1,U1,V1,X1,Y1,Z1
1390-70-B-11X	Unheated WindObserver 70	
1390-75-B-11X	Unheated WindObserver 75	
1390-90-B-11X	Unheated WindObserver 90	
1390-65-B-21X	Heated WindObserver 65	A0,B4,C1,E1,F1,G0000,H2,J1,K1,L1,M4,NQ,O1,P1,T1,U1,V1,X1,Y1,Z1
1390-70-B-31X	Heated WindObserver 70	
1390-75-B-31X	Heated WindObserver 75	
1390-90-B-31X	Heated WindObserver 90	

#### WindObserver Orientation - North Indicator and UV Wind Components

North alignment is indicated by the north arm, the red marker on the base/mounting adaptor indicates which arm is WindObserver north.

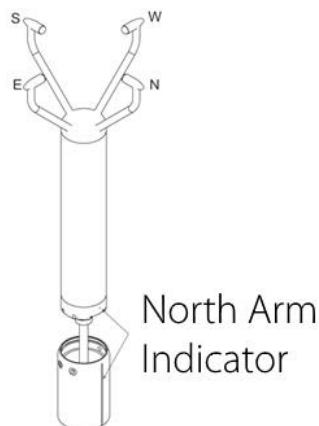

### WindMaster

#### WindMaster Connection Details

Function	MetConnect Pin	WindMaster Connector Pin
Sig Gnd	7	4
Supply +	6	11
Supply -	1	12
RS422+ input	5	2
RS422- input	2	1
RS422+ output	3	5
RS422- output	4	6
Screen shield	-	31

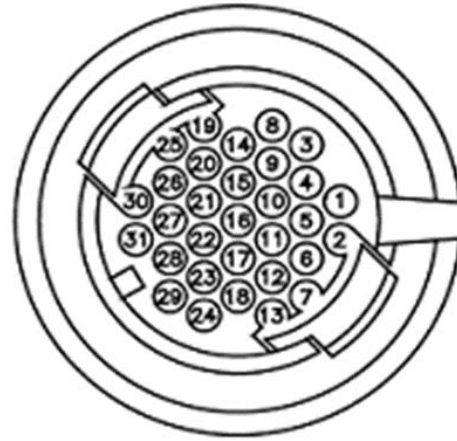

#### WindMaster Configuration Settings

Gill Part Number	WindMaster Model	WindMaster Configuration Settings
1590-PK-020	WindMaster	M4,U1,O1,L1,P1,B4,H2,NQ,E1,T1,S1,C2,A4,I1,J1,V1,X1,G0,K0,F1 1,F2 0,F3 1
1561-PK-020	WindMaster Pro	
1590-PK-130	WindMaster RA	

#### WindMaster Orientation - North Marker and U/V/W Wind Components

North is indicated as shown on the drawing below:

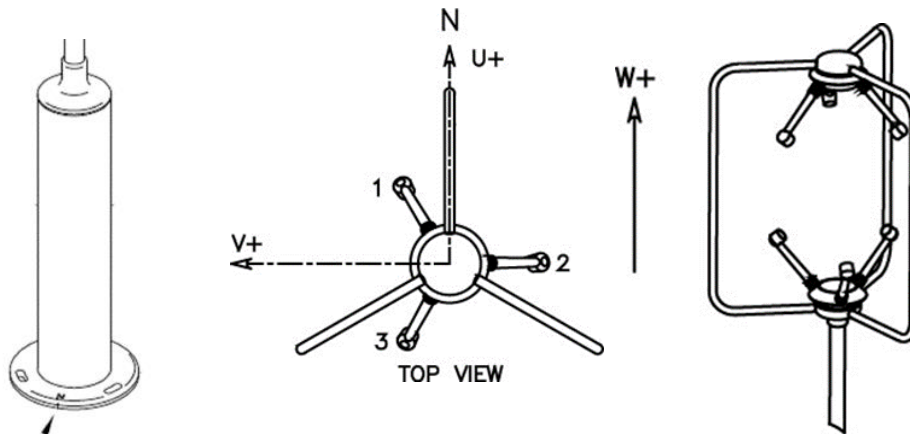

North Alignment Symbol and Notch

### Appendix D - MetConnect Default Set-up

The MetConnect default set up is shown below. The set up can be changed using MetSet software as described in Appendix E.

Setting	
Comms	RS232
Baud Rate	19200
Data Connection	Data Bits 8, Parity None, Stop Bits 1, Flow Control None.
Node ID	Q
Output Rate	1Hz
Message Mode	Continuous
ASCII Set Up	Carriage Return and Line Feed, Echo On
North Alignment	0
Wind Sensor	On
Wind Speed Units	MS (metres/sec)
Wind Direction Units	Degrees
Temperature Sensor	On
Temperature Units	C (degrees Celsius)
Dewpoint Sensor	On
Dewpoint Units	C (degrees Celsius)
Pressure Sensor	On
Pressure Units	hPa (Hectopascals)
Humidity Sensor	On
Humidity Units	% (% Relative Humidity)
Report Format	Node, Polar, (Wind Direction and Wind Speed), Pressure, Humidity, Temperature, Dewpoint, PRT, AN1, AN2, DIG1, Volts, Status, Checksum.
Status Message Output	On
Report Message Output	On
Unit Message Output	On
Inputs Message Output	On
PRT Sensor	<b>On</b>
PRT Units	C (degrees Celsius)
AN1 Sensor Type	Not Configured
AN1 Units	#
AN1 Analogue Input Type	Not Configured
AN1 Substitute Name	-
AN2 Sensor Type	Not Configured
AN2 Units	#
AN2 Analogue Input Type	Not Configured
AN2 Substitute Name	-
DIG1 Sensor Type	Not Configured
DIG1 Units	#
DIG1 Digital Count	Not Configured
DIG 1 Substitute Name	-
Output Sentence	Comma Separated Variable



### Appendix E - MetConnect Safe Mode

MetConnect has been designed with a “Safe Mode” feature.

Safe Mode allows communications with the MetConnect irrespective of its configuration and can be used to reconfigure the MetConnect (To factory settings if required) or confirm current settings. Safe Mode is useful when connecting a MetConnect using a non-default communication set-up (e.g. RS485) to a PC running RS232.

#### To Use Safe Mode using MetSet

1. Connect MetConnect to the PC running MetSet using the M12 to USB cable or alternative RS232 to USB adaptor.
2. Open MetSet software
3. Click on the “**CONNECT AND READ**” button
4. MetSet will display a CONNECTION pop-up window
5. When MetSet has completed the port scan click on the **SAFE MODE** tab (see below)
6. Click on **NEXT**
7. Enter the **COM** port number
8. Click on **NEXT**
9. A new message will be displayed. Click on **NEXT** again
10. MetSet will now temporarily reset the MetConnect to RS232 communications
11. MetSet can now be used as described in Appendix F

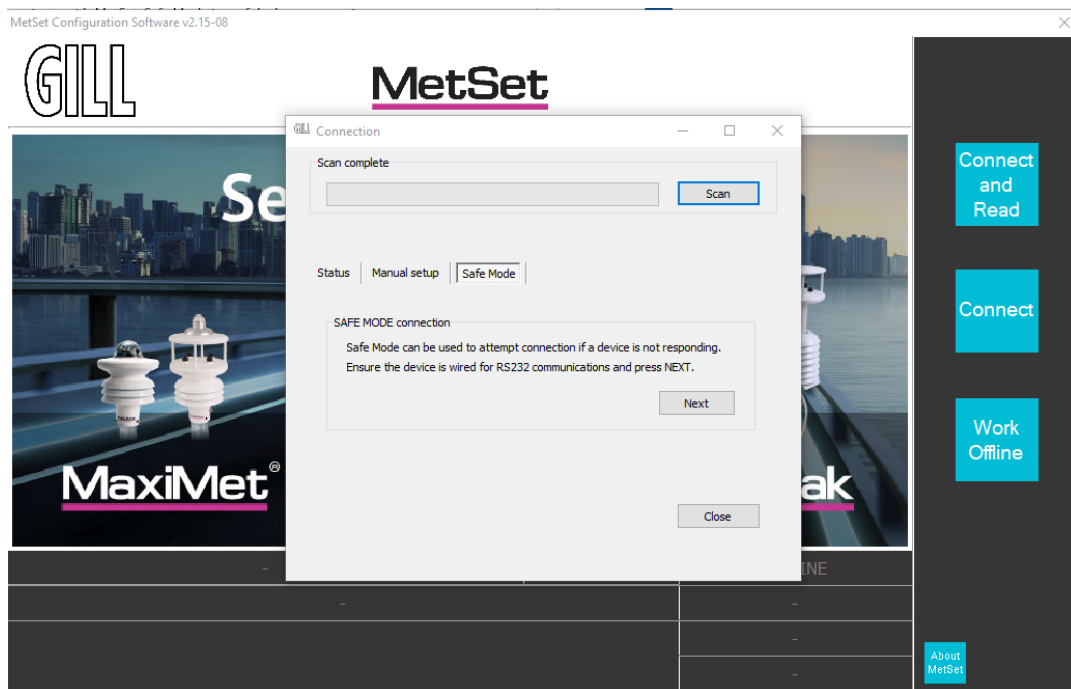

CONNECTION pop-up window with SAFE MODE tab selected

### Appendix F - MetSet Software

Gill Instruments provide a free of charge software package called MetSet to enable the MetConnect to be set-up.

MetSet software can be downloaded from [www.gillinstruments.com](http://www.gillinstruments.com).

**i** Gill recommend reading Appendix E (MetConnect Safe Mode) before changing the MetConnect set-up.



#### Using MetSet to connect to MetConnect

To use MetSet:

1. **Download MetSet** from [gillinstruments.com](http://gillinstruments.com)
2. **Install MetSet** on your PC
3. **Open MetSet** – it may appear in a “Gill” program folder
4. **Connect MetConnect** to your PC (Gill can supply a USB to M12 cable if required)
5. Click on the “**Connect**” or “**Connect and Read**” button
  - a. The “Connection” box will appear and scan for the COM port connected to MetConnect
  - b. When MetSet identifies the COM port it will move to the main set-up screen
  - c. If a “No device found” box appears:
    - i. Check the PC for a USB driver as follows:
      - a. Type “Device Manager” into the Windows Search Box
      - b. Click on “Ports (COM & LPT)”
      - c. Check for “USB Serial Port (COM x)”, if this is not present then the PC requires a USB driver. The driver can be downloaded from the internet
      - d. Once the driver is downloaded, close MetSet and return to Step 3 above
    - ii. Check the cable between the MetConnect and PC is properly secure at both ends
6. Once a connection has been established with MetConnect, MetSet will
  - a. Display the current MetConnect set-up (if selected as part of the set-up, press CLOSE to continue)
  - b. Display the MetSet set-up screen (see next section)

### MetSet set-up screen explained

MetSet uses a Graphical User Interface (GUI). The navigation aids within MetSet are shown below. The terms shown in the table (Button, Tab, Menu, etc.) will be used to describe how to use MetSet.

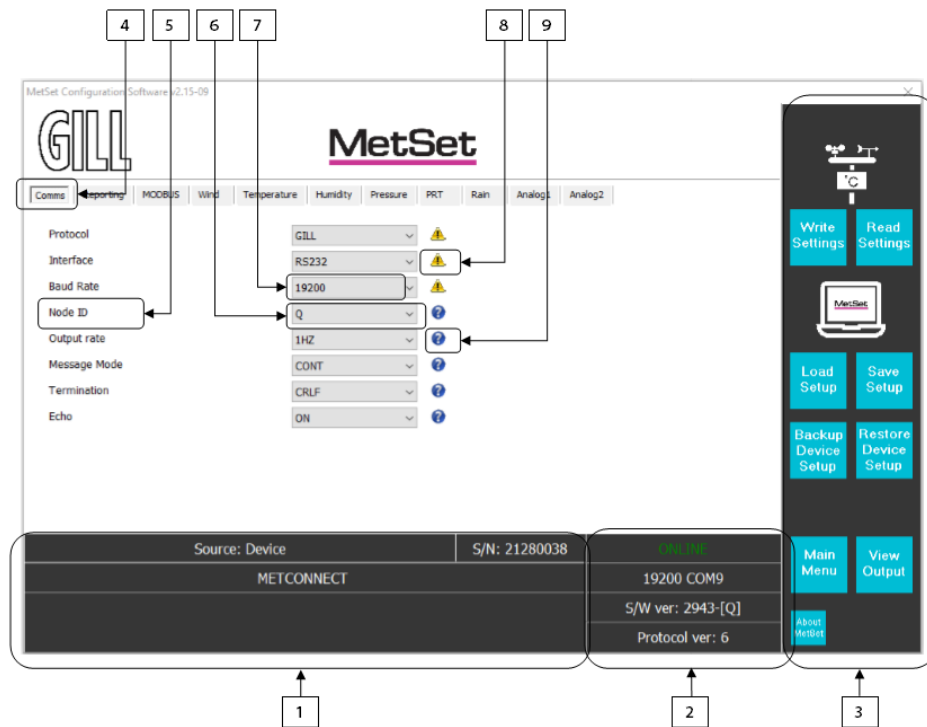

	Navigation Aid	Purpose
1	MetConnect Information	Information about the MetConnect currently connected to MetSet
2	MetSet information	Summary information about the MetSet program
3	MetSet <b>Button</b>	A blue button to load data and templates into and out of MetSet, and help navigate within MetSet
4	Feature <b>Tab</b>	To move between Feature Groups or Sensors being set up
5	Feature <b>Name</b>	To identify the specific Feature being set up
6	Feature <b>Menu</b>	A drop down menu that offers the available set up options for that feature
7	Feature <b>Setting</b>	A text box that allows numbers or text to be entered
8	Feature <b>Warning</b>	Hover over this icon to see more warnings about the use of this feature
9	Feature <b>Information</b>	Hover over this icon to see more information about the feature



### Using MetSet to set up MetConnect

Once the current MetConnect set-up has been downloaded, MetSet can be used to change the set-up as required. MetSet can be used to:

- Change the communications set-up
- Change the data output rate, the data included in the output and the order of data provided
- Control the sensors and change the measurement units and set the scale of additional inputs

### Using MetSet to change the communications set-up

MetSet can be used to change the communications set-up in MetConnect.

-  Once Metset is communicating with MetConnect make a note of the COMMS port being used by MetSet, which is shown the MetSet Information section (indicated "2" above). In the screen above COM9 is being used.
-  To read the current set-up of the MetConnect, click on the **READ SETTINGS** button.
-  When all necessary changes have been made, click on the **WRITE SETTINGS** button. Changes to sensors and measurements will happen once the new set-up is loaded, changes to communications will happen when the MetConnect is next powered up.

### To change the set-up for RS232/RS422/RS485/SDI-12

To select RS232, RS422 RS485 or SDI-12:

-  1. From the MetSet set-up screen, select the **COMMS** tab
- 2. Set the **INTERFACE** menu to **RS232, RS422, RS485** or **SDI-12** as required
- 3. Set the **BAUD RATE, NODE ID, OUTPUT RATE** and **MESSAGE MODE** as required.
- 4. Click on the **SAVE SETUP** button to store the set up on the PC (**Optional**)
- 5. When all set-up changes are complete, click the **WRITE SETTINGS** button

Additional information about SDI-12 commands, including measurement commands and data responses can be found in Appendix I.

### To change the set-up for MODBUS

To select MODBUS:

-  1. From the MetSet set-up screen, select the **COMMS** tab
- 2. Set the **PROTOCOL** menu to **MODBUS**
- 3. Set the remaining menus to the required settings
- 4. Select the **MODBUS** tab
- 5. Set the menus to the required settings.
- 6. Click on the **SAVE SETUP** button to store the set up on the PC
- 7. When all set-up changes are complete, click the **WRITE SETTINGS** button

Additional information about MODBUS can be found in Appendix G.

### To change the set-up for NMEA 0183

To select NMEA:

-  1. From the MetSet set-up screen, select the **REPORTING** tab
- 2. Set the **REPORT FORMAT** menu to **NMEA**
- 3. Select the **COMMS** tab
- 4. Check the **INTERFACE** is set to the required interface type
- 5. Check the **BAUD RATE** is set to the required baud rate
- 6. Click on the **SAVE SETUP** button to store the set up on the PC
- 7. When all set-up changes are complete, click the **WRITE SETTINGS** button

Additional information about NMEA can be found in Appendix H.

### Using MetSet to change the output rate and output data

#### To change the Measurement Output Rate

MetConnect can supply data at different output rates or when polled.

To select the measurement output rate:

1. Connect the MetConnect to a PC running MetSet
2. Open MetSet
3. Select the **COMMS** tab
4. Set the **MESSAGE MODE** menu to **CONT** or **POLLED** as required
5. Set the **OUTPUT RATE** menu to the rate required (see note below when using polled mode)
6. Click on the **SAVE SETUP** button to store the set up on the PC
7. When all set-up changes are complete, click the **WRITE SETTINGS** button

Note: When used in polled mode the unit will supply the most recent valid data sample, according to the OUTPUT RATE set in MetSet. The response will normally be provided within the following times:

- After initial switch on - 10 seconds
- Units without a wind sensor - 3 seconds
- Units with a wind sensor - 30 ms (typically)

#### To change the Measurement Output Data

MetConnect can be set up to supply measured parameters in:

- A default message
- A full data message
- A customer message

To change the data contained in a message:

1. Select the **REPORTING** tab
2. Set the **REPORT FORMAT** menu to **USERDEF**
3. Use the drop down menus in the **SELECT PARAMETERS TO REPORT** window to select the parameters to be contained in the message and the order of parameters
4. Click on the **SAVE SETUP** button to store the set up on the PC
5. When all set-up changes are complete, click the **WRITE SETTINGS** button

The messages that will be sent on MetConnect power up can also be selected in the **REPORTING** tab.

### Using MetSet to control sensors, change units and set the scale of additional inputs

#### To control sensors and change measurement units

##### To set-up MetConnect standard sensors

The measurement data supplied by each of the standard sensors can be:

- The sensor data can be switched ON or OFF
- The units of measurement can be selected

MetSet can be used to set-up the measurement data supplied by each standard sensor.

#### To set up the measurement units and scale of additional sensors

To set-up the ANALOG 1 and ANALOG 2 sensors



1. Select the appropriate tab (e.g. **ANALOG 1**)
2. Set the **AN1 SENSOR** menu to **ON**
3. Set the **SENSOR TYPE** menu to the required parameter (e.g. SOLAR) this will select the appropriate measurement units available
4. In the **SUBSTITUTE NAME** text field enter a parameter name
5. Set the **UNITS** menu to the required units
6. Set the **ANALOG INPUT TYPE** menu to the required input (**VOLTAGE** or **CURRENT**)
7. Using the **SHOW HIGH INPUT AS** and **SHOW LOW INPUT AS** text fields set the scaling for the input
8. The **SHOW HIGH INPUT AS** should be the parameter value (e.g. **1600** w/m<sup>2</sup>) required at maximum input (i.e. 5v or 20mA)
9. The **SET LOW INPUT** should be the parameter value (e.g. **0** w/m<sup>2</sup>) required at minimum value (i.e. 0v or 4mA).
10. Click on the **SAVE SETUP** button to store the set up on the PC
11. When all set-up changes are complete, click the **WRITE SETTINGS** button

To set-up the RAIN sensor



1. Select the **RAIN** tab
2. Set the **RAIN SENSOR** menu to **ON**
3. Set the **SENSOR TYPE** menu to **RAIN**
4. In the **SUBSTITUTE NAME** text field enter a parameter name
5. Set the **UNITS** menu to the required units
6. Set the **TIP SIZE** menu to the tip size of the connected rain gauge in mm
7. Click on the **SAVE SETUP** button to store the set up on the PC
8. When all set-up changes are complete, click the **WRITE SETTINGS** button

To set-up the PRT TEMPERATURE sensor



1. Select the **PRT TEMP** tab
2. Set the **PRT TEMPERATURE SENSOR** menu to **ON**
3. Set the **PRT UNITS** menu to the required units
4. Click on the **SAVE SETUP** button to store the set up on the PC
5. When all set-up changes are complete, click the **WRITE SETTINGS** button

### Appendix G - MetConnect ASCII Data Output

#### MetConnect default ASCII data

NODE, DIR, SPEED, PRESS, RH, TEMP, DEWPOINT, PRT, AN1, AN2, DIG1, VOLT, STATUS

<STX>Q,014,000.06,1011.2,042.1,+023.0,+009.4,,#,#+04.9,00,<ETX>40

Where:-

	STX
Q	Node letter
014	Wind direction
000.06	Wind speed
1011.2	Pressure
042.1	Humidity
+23.0	Temperature
+009.4	Dewpoint
,	PRT (PRT not configured).
#	Analogue Input 1 (not configured)
#	Analogue Input 2 (not configured)
#	Digital Input 1(not configured)
+04.9	Supply voltage
00	Status code
	ETX
40	Checksum

#### NOTES:

<STX> is the Start of String character (ASCII value 2).

,, is the default output for PRT until configured by MetSet.

# is the default output for Analogue Inputs 1 & 2 and Digital Input 1 until configured by MetSet.

<ETX> is the End of String character (ASCII value 3).

Checksum, the 2 digit Hex Checksum sum figure is calculated from the Exclusive OR of the bytes between (and not including) the STX and ETX characters.

Example configured string is:-

Q,249,000.01,1017.3,049.2,+021.4,+010.3,+040.45,+000.06,+000.04,0000.000,+11.6,00,7C

### To change the data or data order

- ▶ 1. Connect the MetConnect to a PC running MetSet
- 2. Open MetSet
- 3. Select the **REPORTING** tab
- 4. Check the **REPORT FORMAT** feature is set to "**USERDEF**"
- 5. In the fields below "**Select Parameter to Report**", use the drop down menus to select
  - a. the parameter to report and
  - b. the order in which the parameters are reported
- 6. Click on the **SAVE SETUP** button to store the set up on the PC
- 7. When all set-up changes are complete, click the **WRITE SETTINGS** button



### Appendix H - MetConnect MODBUS Data Output

#### MetConnect MODBUS specification

MODBUS	RTU or ASCII.
Baud Rate	9600 or 19200 Baud.
COMMS	RS232 point to point only, RS485 2 wire networkable.

Modbus Parameters ASCII or RTU.

Parameter	Modbus ASCII	Modbus RTU
Character	ASCII 0 to 9 and A to F (Hex)	Binary 0 to 255
Error Check	Longitudinal Redundancy Check (LRC)	Cyclic Redundancy Check (CRC)
Frame Start	Character ':' (3A Hex)	3.5 Characters Silence
Frame End	Characters CR/LF (0D/0A Hex)	3.5 Characters Silence
Gaps in Message	1 Second	1.5 Times Character Length
Start Bit	1	1
Data Bits	7	8
Parity	Even/Odd	None
Stop Bits	1	2

Read Holding Registers function code is 0x03

Diagnostics 0x08

Get Comm event counter 0x0B

Report slave/server ID 0x11

#### MetConnect MODBUS NOTES

1. All registers are 16bit.
2. The first byte is high order and the second is low.
3. Each measurement is comprised of two 16 bit registers.
4. For all registers, the order of the two data bytes comprising the 16-bit register's value is: High Byte/Low Byte.
5. For each 32-bit data type (whether floating point or integer), the order of the first pair of bytes and last pair of bytes is: High Word/Low Word.
6. Registers start at address 40001.
7. Holding registers available in the order of the MetConnect data string (which can be established by the REPORT command in non-Modbus Gill ASCII Mode).
8. If measurements cannot be computed (i.e. a blank field in Gill mode output string), their Holding Register contents shall be set to the Maximum Positive value (0x7FFFFFFF for 32-bit format data (both floating point and integer), and as 0x7FFF for 16-bit format data).

**Note:** After powering up the MetConnect, wait 10 seconds before requesting any measurements.

The default MODBUS registers set up is shown below.

MetConnect Output Parameters	Parameter Data Type	No. of Registers	Default Register Numbers
NODE	4 Bit Character String	2	40001-2
DIRECTION	32 Bit Floating Point Value	2	40003-4
SPEED	32 Bit Floating Point Value	2	40005-6
PRESSURE	32 Bit Floating Point Value	2	40007-8
RELATIVE HUMIDITY	32 Bit Floating Point Value	2	40009-10
TEMPERATURE	32 Bit Floating Point Value	2	40011-12
DEWPOINT	32 Bit Floating Point Value	2	40013-14
PRT	32 Bit Floating Point Value	2	40015-16
AN1	32 Bit Floating Point Value	2	40017-18
AN2	32 Bit Floating Point Value	2	40019-20
DIG1	32 Bit Floating Point Value	2	40021-22
SUPPLY VOLTAGE	32 Bit Floating Point Value	2	40023-24
STATUS	32 Bit Unsigned Integer (UINT)	2	40025-26

### To change the output format to MODBUS

1. Connect the MetConnect to a PC running MetSet
2. Open MetSet
3. Select the **COMMS** tab
4. Set the **PROTOCOL** menu to **MODBUS**
5. Set the **INTERFACE** menu to the required interface
6. Set the **BAUD RATE** menu to the required baud rate
7. Select the **MODBUS** tab
8. Set the parameters in the **MODBUS** tab to the required settings
9. Click on the **SAVE SETUP** button to store the set up on the PC
10. When all set-up changes are complete, click the **WRITE SETTINGS** button

### To change the use of the MODBUS registers

1. Connect the MetConnect to a PC running MetSet
2. Open MetSet
3. Select the **REPORTING** tab
4. Check the **REPORT FORMAT** feature is set to **"USERDEF"**
5. In the fields below **"Select Parameter to Report"**, use the drop down menus to select
  - a. the parameter to report and
  - b. the order in which the parameters will be reported
6. The order that the parameters are display will set the MODBUS register used:
  - a. Parameter 1 = Register 40001-2
  - b. Parameter 2 = Register 40003-4
  - c. Parameter 3 = Register 40004-5
  - d. etc.
7. Click on the **SAVE SETUP** button to store the set up on the PC
8. When all set-up changes are complete, click the **WRITE SETTINGS** button

The screenshot shows the MetSet Configuration Software v2.15.11 interface. The 'Reporting' tab is selected. The 'Report Format' is set to 'USERDEF'. The 'Select Parameters to Report' section shows a list of parameters: NODE, DIR, SPEED, PRESS, RH, TEMP, DEWPOINT, FRT, ANI. A table below maps these parameters to MODBUS registers:

Register	Parameter
40001-2	NODE
40003-4	DIR
40005-6	SPEED
40007-8	PRESS
40009-10	RH
40011-12	TEMP
etc.	DEWPOINT, FRT, ANI

### Appendix I - MetConnect NMEA 0183 Data Output

#### MetConnect NMEA0183

When reporting in NMEA0183 format the following sentences will be used

- **MWV** sentence to report wind direction and speed
- **XDR** sentence to report temperature, humidity, pressure
- **MET** sentence to report prt temperature, analogue inputs and digital input.

In each case \*hh is a checksum, the 2 digit Hex Checksum sum figure is calculated from the Exclusive OR of the bytes between (and not including) the \$ and \* characters.

<CR> is a Carriage return character (ASCII hex value d)

<LF> is a Line Feed Character (ASCII hex value a)

#### MWV - Wind direction/speed

```
      1 2   3 4 5  
      | |   | | |  
$--MwV,x,a,x.x,a,a*hh<CR><LF>
```

Field Number:

1. Direction
2. R - relative
3. Speed
4. Units N - Knots
5. Validity flag, A - Valid, V - invalid

Example

```
$WIMWV,105,R,000.03,N,V*1D
```

#### XDR - Transducer Measurement

```
      1 2   3 4           n  
      | |   | |           |  
$--XDR,a,x.x,a,C--C, ..... *hh<CR><LF>
```

Field Number:

1. Transducer Type
2. Measurement Data
3. Units of measurement
4. Name of transducer

Example

```
$WIXDR,C,+025.7,C,TEMP,P,1.0105,B,PRESS,H,023.3,P,RH*39
```

### MET - Custom measurement

1	2	3	4	5	6	7	8

\$--MET,C--C,X.X,C--C,X.X,C--C,X.X,C--C,X.X\*hh<CR><LF>

Field Number:

1. Transducer name
2. Measurement Data
3. Transducer name
4. Measurement Data
5. Transducer name
6. Measurement data
7. Transducer name
8. Measurement data

Example

\$WIMET,PRT,+026.87,VOLT1,+2499.6,VOLT2,+3287.0,RAIN,0000.000,\*7B

### Appendix J - MetConnect SDI-12 Data Output

#### Using MetConnect to set up SDI-12 output

MetConnect supports SDI-12 data provision with and without CRC. To select SDI-12 follow the instructions below.

1. Connect the MetConnect to a PC running MetSet
2. Open MetSet
3. Select the **COMMS** tab
4. Set the **INTERFACE** menu to **SDI-12**
5. Click on the **SAVE SETUP** button to store the set up on the PC
6. When all set-up changes are complete, click the **WRITE SETTINGS** button

#### SDI-12 Units of Measure

Relative Wind Speed:	Metres/Second.
Relative Wind Direction:	Degrees
Temperature:	Degrees C
Relative Humidity:	%
Dewpoint:	Degrees C
Pressure:	HectoPascals
Total precipitation:	mm
AN1	As defined by MetSet
AN2	As defined by MetSet
DIG1	As defined by MetSet
PRT	As defined by MetSet
Date:	yyyymmdd
Time:	hhmmss
Status	4 Digit Sensor Status code (e.g. 00 for a no fault condition)

### SDI-12 Commands

Note: Unavailable measurements shall be "padded", e.g.: +999.99.

?!	Unit Address (default is 0).
aAb!	Change unit address (a = 0).
al!	Unit identifier Firmware and Serial Number.
aM!	Wind direction (degrees), wind speed (m/s), Temperature (°C), Pressure (hPa/mbar) and Humidity (%).
aM1!	Wind direction (degrees), wind speed (m/s), Temperature (°C), Pressure (hPa/mbar) and Dewpoint (°C).
aM2!	Wind direction (degrees), wind speed (m/s), 2 digit Wind only Status Codes.
aM3!	Temperature (°C), Humidity (%), Dewpoint (°C) and full MetConnect Status Codes.
aM4!	Pressure (hPa/mbar).
aM5!	PRT, Analogue Input 1, Analogue input 2 and Digital Input 1.
aM6!	PRT.
aM7!	Analogue Input 1 and Analogue Input 2.
aM8!	Digital Input 1.
aM9!	Power Supply Voltage (Volts).
aD0!	Request a line of the above data.

Command	Description	Response	Example
?!	Unit Address	a<CR><LF>	0<CR><LF>
aAb!	Change the unit address a = 0, the default. b = the new address.	b<CR><LF>	1<CR><LF>
a!	Send Unit Identification	a<firmware><sn><CR><LF>	013GillInst 40116370005<CR><LF>
aM!	Wind Direction/Speed (direction in Degrees, speed in Metres/Sec), Temperature (degrees-C), Pressure (Hecto Pascals/millibars), Humidity (%) and a 2 digit Status Code	attn<CR><LF> a is unit identifier. ftt is time in seconds. n is number of data values Measurement command to retrieve a reading of the maximum time to complete a measurement, have data ready and the number of data values.	00045<CR><LF> 0 is unit identifier. 004 is 4 sec. measurement. 5 is the number of data readings (Direction, Speed, Temperature, Pressure and Humidity).
0D0!	Retrieve a line of the above data.	a<dir><mag><temp><pressure><humidity><CR><LF>	0+220+000.01+021.6+ 1013.0+041.9<CR><LF>
aM1!	Wind Direction/Speed (direction in Degrees, speed in Metres/Sec), Temperature (degrees C), Pressure (Hecto Pascals/millibars) and Dewpoint (degrees C).	attn<CR><LF>	00055<CR><LF>
0D0!	Retrieve a line of the above data.	a<dir><mag><temp><pressure><dewpoint><CR><LF>	0+357+000.03+021.6+ 1013.0+008.0<CR><LF>
aM2!	Wind Direction/Speed (direction in Degrees, speed in Metres/Sec) and a 2 digit Wind only Status Code.	attn<CR><LF>	00053<CR><LF>
0D0!	Retrieve a line of the above data.	a<dir><mag><status><CR><LF>	0+029+000.01+00<CR><LF>
aM3!	Temperature (degrees C), Humidity (%), Dewpoint (Degrees C) and Full Sensor Status Codes.	attn<CR><LF>	00054<CR><LF>
0D0!	Retrieve a line of the above data.	a<temp><humidity><dewpoint><status><CR><LF>	0+21.6+041.0+0007.8+00<CR><LF>
aM4!	Pressure (Hecto Pascals/millibars).	attn<CR><LF>	00051<CR><LF>
0D0!	Retrieve a line of the above data.	a<pressure><CR><LF>	0+1013.0<CR><LF>
aM5!	PRT, Analogue Input 1, Analogue Input 2 and Digital Input 1	attn<CR><LF>	00054<CR><LF>
0D0!	Retrieve a line of the above data.	a<prb><A11><A12><dig1><CR><LF>	0+027.65+0.0034-099903+0135.000<CR><LF>
aM6!	PRT.	attn<CR><LF>	00051<CR><LF>
0D0!	Retrieve a line of the above data.	a<prb><CR><LF>	0+027.65<CR><LF>
aM7!	Analogue Input 1 and Analogue Input 2	attn<CR><LF>	00052<CR><LF>
0D0!	Retrieve a line of the above data.	a<A11><A12><CR><LF>	0+3.5380+017947<CR><LF>
aM8!	Digital Input 1.	attn<CR><LF>	00051<CR><LF>
0D0!	Retrieve a line of the above data.	a<dig1><CR><LF>	0+0408.000<CR><LF>
aM9!	Power Voltage (Volts)	attn<CR><LF>	00011<CR><LF>
0D0!	Retrieve a line of the above data.	a<voltage><CR><LF>	0+12.5<CR><LF>



### SDI-12 Commands with CRC

Note: Unavailable measurements shall be "padded", e.g.: +999.99.

aMC!	Wind direction (degrees), wind speed (m/s), Temperature (°C), Pressure (hPa/mbar), Humidity (%) and CRC.
aMC1!	Wind direction (degrees), wind speed (m/s), Temperature (°C), Pressure (hPa/mbar), Dewpoint (°C) and CRC.
aMC2!	Wind direction (degrees), wind speed (m/s), 2 digit Status Code and CRC.
aMC3!	Temperature (°C), Humidity (%), Dewpoint (°C) and CRC.
aMC4!	Pressure (hPa/mbar) and CRC.
aMC5!	PRT, Analogue Input 1, Analogue input 2, Digital Input 1 and CRC.
aMC6!	PRT and CRC.
aMC7!	Analogue Input 1, Analogue Input 2 and CRC.
aMC8!	Digital Input 1 and CRC.
aMC9!	Power Supply Voltage (Volts) and CRC.
aD0!	Request a line of the above data.

Command	Description	Response	Example
<b>aMC!</b>	Wind Direction/Speed (direction in Degrees, speed in Metres/Sec), Temperature (degrees-C), Pressure (Hecto Pascals/millibars) Humidity (%) and CRC.	atttn<CR><LF> a is unit identifier. tft is time in seconds.n is number of data values. n is number of data values. Measurement command to retrieve a reading of the maximum time to complete a measurement, have data ready and the number of data values. a<dir><mag><temp><pressure><humidity><CRC>><CR>><LF>	00045<CR><LF> 0 is unit identifier. 004 is 4 sec. measurement. 5 is the number of data readings (Direction, Speed, Temperature, Pressure, Humidity and CRC).
<b>0D0!</b>	Retrieve a line of the above data.		0+139+000.06+022.2+1017.8 +042.7BIQ<CR><LF>
<b>aMC1!</b>	Wind direction in Degrees, wind speed in m/s, Temperature (degrees C), Pressure (Hecto Pascals/millibars), Dewpoint (degrees C) and CRC.	atttn<CR><LF>	00055<CR><LF>
<b>0D0!</b>	Retrieve a line of the above data.	a<dir><mag><temp><pressure><dewpoint><CRC>><CR>><LF>	0+140+000.06+022.2+1017.7 +009.0D[Z<CR><LF>
<b>aMC2!</b>	Wind Direction/Speed (direction in Degrees, speed in Metres/Sec), a 2 digit Status Code and CRC.	atttn<CR><LF>	00053<CR><LF>
<b>0D0!</b>	Retrieve a line of the above data.	a<dir><mag><status><CRC><CR><LF>	0+098+000.04+00@sh<CR><LF>
<b>aMC3!</b>	Temperature (degrees C), Humidity (%), Dewpoint (Degrees C) and CRC.	atttn<CR><LF>	00053<CR><LF>
<b>0D0!</b>	Retrieve a line of the above data.	a<temp><humidity><dewpoint><status><CRC>><CR>><LF>	0+022.2+042.7+009.0+00LV[<CR>><LF>
<b>aMC4!</b>	Pressure (Hecto Pascals/millibars) and CRC.	atttn<CR><LF>	00051<CR><LF>
<b>0D0!</b>	Retrieve a line of the above data.	a<pressure><CRC><CR><LF>	0+1017.8GM* <CR><LF>
<b>aMC5!</b>	PRT, Analogue Input 1, Analogue Input 2, Digital Input 1 and CRC.	atttn<CR><LF>	00054<CR><LF>
<b>0D0!</b>	Retrieve a line of the above data.	a<prt><AI1><AI2><dig1>><CRC><CR><LF>	0-001.19+0000.6+0000.4+0000.000 CQx <CR><LF>
<b>aMC6!</b>	PRT and CRC.	atttn<CR><LF>	00051<CR><LF>
<b>0D0!</b>	Retrieve a line of the above data.	a<prt><CRC><CR><LF>	0-001.19IT@ <CR><LF>
<b>aMC7!</b>	Analogue Input 1, Analogue Input 2 and CRC.	atttn<CR><LF>	00052<CR><LF>
<b>0D0!</b>	Retrieve a line of the above data.	a<AI1><AI2><CRC><CR><LF>	0+0000.6+0000.4FE-<CR><LF>
<b>aMC8!</b>	Digital Input 1 and CRC.	atttn<CR><LF>	00051<CR><LF>
<b>0D0!</b>	Retrieve a line of the above data.	a<dig1>><CRC><CR><LF>	0+0000.000EgO<CR><LF>
<b>aMC9!</b>	Power Voltage (Volts) and CRC	atttn<CR><LF>	00011 <CR><LF>
<b>0D0!</b>	Retrieve a line of the above data.	a<voltage><CRC><CR><LF>	0+12.2K@R<CR><LF>

### Appendix K - Polled Mode Commands

When in Polled Mode the MetConnect will only take action when the host system sends a command to the MetConnect. The commands available in Polled Mode are shown below.

Command	Description	MetConnect Response
?	Ensures that the Sensor is enabled to cover the event that a power down has occurred.	None
A ... Z	Appropriate unit designator sent to retrieve a line of data (default is Q).	Data output string
!	Sent to disable poll mode and reduce possibility of erroneous poll generation.	None
?&	Sent to confirm unit designator	A ... Z (as configured)

Gill recommend that in polled mode the following sequence is used for every poll for information.

When in polled mode the system will typically respond to the data command within 30mS with the last valid data sample when set for 1Hz output rate.

If a Wind Sensor is not connected to MetConnect then allow at least 3 seconds for a poll request reading output. If the unit is powered down after use or upon switch on then allow 10 seconds from switch on before sending poll commands.

### Appendix L - MetView Software

Gill Instruments provide a free of charge software package called MetView to enable the data provided by MetConnect to be viewed. MetView is compatible with Windows 7 and Windows 10.

MetSet software can be downloaded from [www.gillinstruments.com](http://www.gillinstruments.com).



#### Using MetView to connect to MetConnect

To use MetView:

1. **Download MetView** from [gillinstruments.com](http://gillinstruments.com)
2. **Install MetView** on your PC
3. **Open MetView** – it may appear in a “Gill” program folder
4. Connect MetConnect to your PC (Gill can supply a USB to M12 cable if required)
5. Click on the “**Connect**” button. MetView will scan the PC COM ports and identify the one connected to MetConnect.
6. If MetView does not find the MetConnect,
  - a. Click on the **TROUBLESHOOT** button and enter the Com port being used to connect to MetConnect.
  - b. The “Connection” box will appear and scan for the COM port connected to MetConnect
  - c. When MetSet identifies the COM port it will move to the main set-up screen
  - d. If a “No device found” box appears:
    - i. Check the PC for a USB driver as follows:
      - e. Type “Device Manager” into the Windows Search Box
      - f. Click on “Ports (COM & LPT)”
      - g. Check for “USB Serial Port (COM x)”, if this is not present then the PC requires a USB driver. The driver can be downloaded from the internet
      - h. Once the driver is downloaded, close MetSet and return to Step 3 above
    - ii. Check the cable between the MetConnect and PC is properly secure at both ends
7. Once a connection has been established with MetConnect, MetView will display the main screen (below)

### MetView main screen explained

MetView uses a Graphical User Interface (GUI). The navigation aids within MetView are shown below.

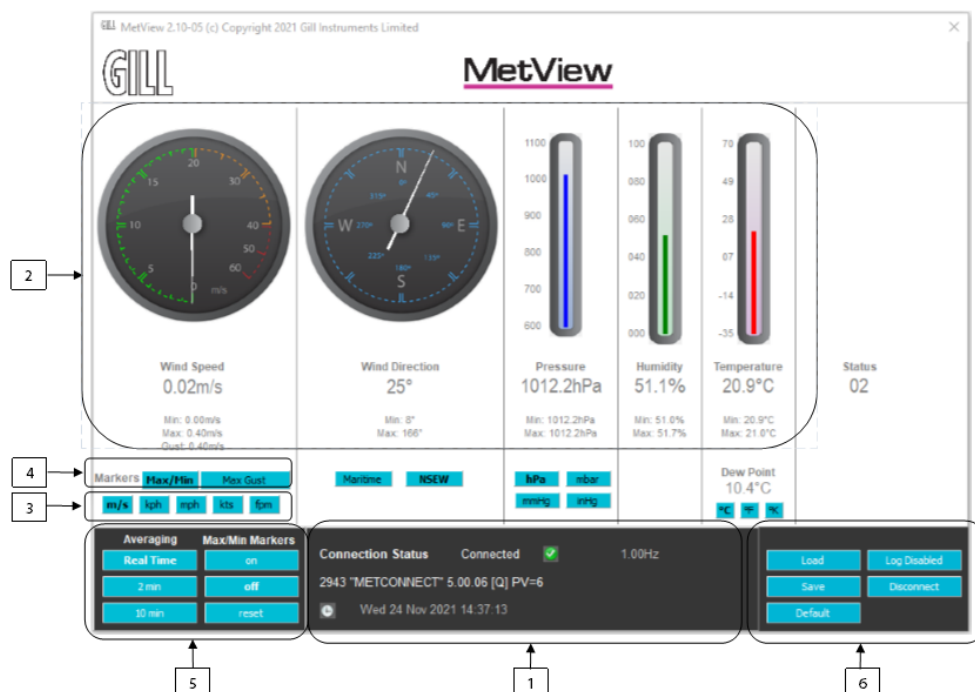

	Navigation Aid	Purpose
1	MetConnect Information	Information about the MetConnect currently connected to MetView
2	MetConnect Data	Graphical representation of the data received from MetConnect. Note: the Status information provided by MetConnect is also displayed
3	Unit Buttons	These buttons change the scale on the graphical displays
4	Min/Max Buttons	These buttons add markers to the displays to show Min/Max or Gust data
5	Averaging Buttons	These buttons allow the data received from MetConnect to be shown in real time or for average data to be displayed
6	MetView Function Buttons	These buttons provide a range of functions within MetView as detailed below

**i** The screen shown above shows data from a range of integrated sensors. If additional sensors have been added to the MetConnect and the additional data is supplied to MetView, then this data will be added to the screen automatically.

### Using MetView Function Buttons

	MetView Function Button Name	Purpose
1	Default	This button returns the display units to the default units.
2	Log Enable	This button displays a pop-up box that can be used to enable logging.
3	Log Disable	This button displays a pop-up box that can be used to disable logging.
4	Load	This button enables a set-up file to be loaded to MetConnect. The set-up file can be created using MetSet (see Appendix E) or can be downloaded from a MetConnect.
5	Save	This button enables a set-up file to be downloaded and saved from MetConnect.
6	Disconnect	This button disconnects Metview from MetConnect.

### ENABLING LOGGING in MetView

To use MetView to create and store log files:

1. Click on the **LOG ENABLE** button. A pop up box will be displayed (see below)
2. Tick the **ENABLE LOGGING** box to enable data logging
3. In the **LOG FILE LOCATION** field enter the location where the log files should be stored
4. To include a standard header in each log file enter the required heading in the **LOG FILE HEADER** field
5. To create log files of a standard length
  - a. Tick the **LOG FILE ROTATION** box
  - b. In the **MAX ENTRIES PER LOG FILE** field, enter the number of lines of data required for each file
6. Tick the **ADD TIMESTAMP** box to add a timestamp to each line of data
7. Click **OK** to start creating log files
8. If **LOG FILE ROTATION** has been ticked, MetView will now create log files of the specified size until instructed to stop
9. If **LOG FILE ROTATION** has not been ticked, MetView will now create a single log file until instructed to stop

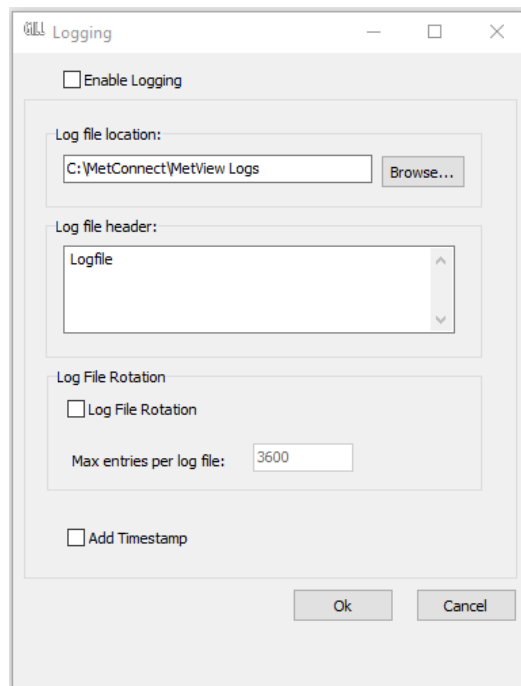

### DISABLING LOGGING in MetView

To use MetView to create and store log files:

1. Click on the **LOG DISABLE** button. A pop up box will be displayed (see above)
2. Untick the **ENABLE LOGGING** box to disable data logging
3. Click **OK** to stop logging
4. If **LOG FILE ROTATION** has been ticked, MetView will now create a final log file and save it to the location specified. The file may be shorter than the MAX ENTRIES PER FILE specified
5. If **LOG FILE ROTATION** has not been ticked, MetView will now save a single log file to the location specified

### Appendix M - MetConnect Status Codes

MetConnect is able to include a status code in each measurement string to confirm the reliability of the data or to highlight any potential issues. A list of the status code is provided below.

Code	Status	Description	User Action
00	OK	No fault conditions detected in measurement period	No action required
01	Wind alert	Wind sensor faulty or not available. More information in the Wind Sensor status	Enable the wind sensor status and refer to specific status code for further action (see section Wind Sensor Status below)
02	PRT alert	PRT faulty or measurement not available	Check connections between PRT and MetConnect; Contact Gill Technical Support
10	Temperature alert	Temperature and humidity probe faulty or temperature measurement not available or invalid	Check connections between the temperature/humidity probe and MetConnect; Contact Gill Technical Support
20	Dewpoint alert	Temperature or humidity measurement not available or invalid	Check connections between the temperature/humidity probe and MetConnect; Contact Gill Technical Support
40	Humidity alert	Temperature and humidity faulty or humidity measurement not available or invalid	Check connections between the temperature/humidity probe and MetConnect; Contact Gill Technical Support
80	Pressure Sensor alert	Pressure sensor measurement not available or invalid	Check connections between the pressure sensor and MetConnect; Contact Gill Technical Support
XX	More than one alert	Alert condition that can be the sum of any of the above eg "11" would mean that alerts were present for both the Wind Sensor(01) and Temperature sensor.	Follow above guidance for individual alert condition

### Wind Sensor Status

To output the wind status, the WINDSTAT parameter must be set using the REPORT command for this information to be output.

Code	Status	Condition	User Action
00	OK	No fault conditions detected in measurement period	No action required
01	Wind Sensor - U Axis alert	U Axis (North-South) Axis blocked or faulty	Check for any blockages or damage on the wind sensor. Gently clean the surfaces with water.
02	Wind Sensor - V Axis alert	V Axis (East-West) Axis blocked or faulty	Check for any blockages or damage on the wind sensor. Gently clean the surfaces with water.
03	Wind Sensor - W Axis alert	W Axis (Vertical) Axis blocked or faulty (only applicable if a 3 axis unit is fitted).	Check for any blockages or damage on the wind sensor. Gently clean the surfaces with water
04	Wind Sensor - Axis U and V alert	U and V Axis blocked or faulty	Check for any blockages or damage on the wind sensor. Gently clean the surfaces with water
05	Wind Sensor - Axis U and W alert	U and W Axis blocked or faulty (only applicable if a 3 axis unit is fitted).	Check for any blockages or damage on the wind sensor. Gently clean the surfaces with water
06	Wind Sensor - Axis V and W alert	U and W Axis blocked or faulty (only applicable if a 3 axis unit is fitted).	Check for any blockages or damage on the wind sensor. Gently clean the surfaces with water
07	Wind Sensor - Axis U, V and W alert	U, V and W Axis blocked or faulty (only applicable if a 3 axis unit is fitted).	Check for any blockages or damage on the wind sensor. Gently clean the surfaces with water
08	Wind Sensor - Diagnostics Alert 1	Internal diagnostic alert, data could be uncalibrated	Power cycle unit. If fault has not cleared contact Gill Technical Support.
09	Wind Sensor - Diagnostics Alert 2	Internal diagnostic alert, data could be uncalibrated	Power cycle unit. If fault has not cleared contact Gill Technical Support.
0B	Wind Sensor - Reading alert	Wind Sensor faulty or disconnected or turned off	Check connections between the wind sensor and MetConnect. Power cycle unit. If fault has not cleared contact Gill Technical Support.



### Appendix N - M12 to USB Configuration Cable Installation

The M12 to USB Configuration Cable can be used to connect a MetConnect to a PC running MetSet software. This will allow the MetConnect to be configured and tested prior to installation. **Please note** that this cable should only be used to configure and test the MetConnect and should not be used in normal operation.

If the MetConnect is in default configuration, the M12 to USB Configuration Cable can be connected and the unit configured as required.

If the MetConnect is not in the default configuration (for example MODBUS or SDI-12) then the use of Safe Mode will be necessary. Details of safe mode can be found in Appendix E.

#### Determining M12 to USB Configuration Cable Com Port

To use safe mode it is necessary to determine the COM port that the M12 to USB Configuration Cable is assigned on the PC – this can be confirmed by opening Device Manager on the PC and checking the COM & LPT Port settings as shown:

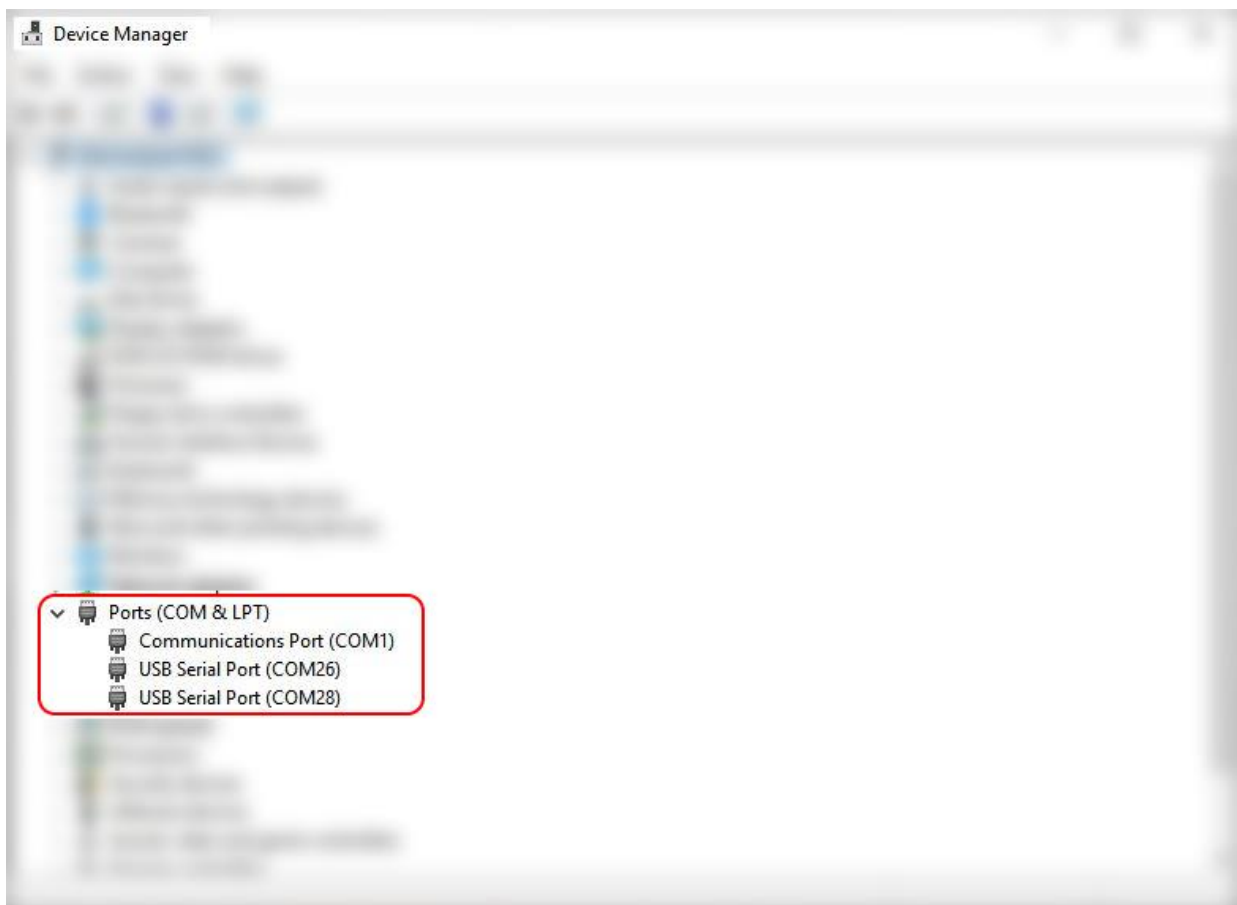

If no COM port is shown, it may be necessary to install device drivers (please contact Gill Instruments Technical Support if drivers are required).

**As a representative of this supplier, we – from Observator – distribute these products. Originating from the Netherlands, Observator has grown into an internationally oriented company with a worldwide distribution network.**

**For more information contact Observator Instruments:**

**Australia**

T: +61 3 8706 5000

E: sales.au@observator.com / service.au@observator.com

**Germany**

T: +49 (0)152 02047306 / +49 (0)152 02047308

E: contact@observator.com

**The Netherlands**

T: +31 (0)180 463411

E: sales@observator.com / service@observator.com

**Poland**

T: +48 537 209 665

E: a.miller@observator.com

**Singapore**

T: +65 68 72 08 63

E: sales@observator.sg

**United Kingdom**

T: +44 (0)783 346 4884

E: info.uk@observator.com

**Welcome to the world of Observator**

Since 1924 Observator has evolved to be a trend-setting developer and supplier in a wide variety of industries. Originating from the Netherlands, Observator has grown into an internationally

oriented company with a worldwide distribution network and offices in Australia, Germany, the Netherlands, Singapore and the United Kingdom.

[www.observator.com](http://www.observator.com)