

# MaxiMet<sup>®</sup> Marine

GMX560 Compact Weather Station

## User Manual



Gill Instruments Limited  
Saltmarsh Park, 67 Gosport Street, Lymington,  
Hampshire, SO41 9EG, UK  
Tel: +44 1590 613500, Fax: +44 1590 613555  
Email: [contact.gi@gill.group](mailto:contact.gi@gill.group) Website: [www.gillinstruments.com](http://www.gillinstruments.com)

# MaxiMet® Marine

## GMX560 Compact Weather Station

### Table of Contents

1. Welcome to the MaxiMet Marine user manual.....	4
1.1. Overview of Content.....	4
1.2. Description of Icons.....	4
1.3. General Notes.....	5
1.4. User Manual Revision History.....	5
2. Product Overview and Functions.....	6
2.1. Wind Speed and Direction Sensor.....	7
2.2. Solar Radiation Shield.....	7
2.3. Barometric Pressure.....	8
2.4. Temperature, Relative Humidity and Dewpoint.....	8
2.5. Compass.....	8
2.6. Compass Declination.....	8
2.7. GPS Option.....	8
2.8. Inclinometer.....	9
2.9. Heating Function Option.....	9
3. Pre-Installation.....	10
3.1. Equipment Supplied.....	10
3.2. Optional Extras/Spares.....	10
3.3. MaxiMet Marine Conformity.....	10
3.4. Right to change and revise.....	11
3.5. Packaging.....	11
3.6. Specification.....	11
3.7. Downloadable Software.....	11
3.8. Setup Requirements.....	11
3.8.1. Host System.....	11
3.8.2. Bench System Test.....	12
4. Installation Guidelines.....	12
4.1. Interference.....	12
4.2. Wind.....	13
4.3. Compass.....	13
4.4. GPS.....	14
4.5. Tilt.....	14
4.6. General Alignment.....	14
5. Connector and pin allocation.....	21
6. Maintain MaxiMet.....	22
6.8. Safe Mode.....	22
6.8.1. Major Repairs.....	22
6.9. Warranty Repairs.....	22
Appendix A - Technical Specification.....	23

# MaxiMet<sup>®</sup> Marine

## GMX560 Compact Weather Station

---

Appendix B - Default Configuration .....	26
Appendix C - Summary of MaxiMet Derived Parameters .....	29
Appendix D - Configuring MaxiMet with MetSet .....	30
Appendix E - Configuring MaxiMet Marine for Modbus .....	47
Appendix F - Configuring MaxiMet for NMEA 0183 Output .....	53
Appendix G - Configuring MaxiMet for SDI-12.....	56
Appendix H - Safe Mode.....	63
Appendix I - Using a Terminal Program to run MaxiMet Marine Tilt function .....	71
Appendix J - Using a Terminal Program to set MaxiMet Date and Time .....	73
Appendix K - Using Gill MetView Software to View the MaxiMet Data String .....	74
Appendix L - Maintenance & fault-finding.....	88
Appendix M - MaxiMet Output Parameters selectable using MetSet Software.....	92
Appendix N - M12 to USB Configuration Cable installation.....	106

# MaxiMet<sup>®</sup> Marine

## GMX560 Compact Weather Station

### 1. Welcome to the MaxiMet Marine user manual.

#### About this manual

This manual provides the information needed to get the best results from MaxiMet Marine  
The most recent version of this manual is available at [gillinstruments.com](http://gillinstruments.com).

**Please read this manual before setting up and installing MaxiMet Marine**



#### 1.1. Overview of Content

The manual is split into 6 chapters. Each chapter represents an activity in the use of the product. Additional detailed information is contained in the Appendices at the end of the manual.

- Chapter 1 explains how the manual is set out
- Chapter 2 provides a brief overview of the product and functions
- Chapter 3 provides pre-installation information needed to set-up the product
- Chapter 4 provides guidelines on how best to install the product
- Chapter 5 provides Connector and wiring information
- Chapter 6 provides guidance for product maintenance and fault finding

#### 1.2. Description of Icons

The following icons are used in this manual.

Icon	Description
	A note that is important and that should be observed
	Information or a recommendation to ensure best results
	The start of a set of instructions

# MaxiMet<sup>®</sup> Marine

## GMX560 Compact Weather Station

### 1.3. General Notes



Before MaxiMet Marine is used for the first time it is essential to read and understand this manual. Please keep the manual safe for future reference.



Care should be taken with MaxiMet Marine at all times. The product should be transported to site in the box, and only removed when ready to install.



During installation MaxiMet Marine should be supported and care should be taken not to drop the product



Care should be taken when wiring the MaxiMet Marine to power and communications.



Maintenance should be limited to the procedures described in this manual. Additional maintenance or cleaning may damage the sensors.



No attempt should be made to open or repair any of the parts of the product. Any attempt will invalidate the warranty provided by Gill Instruments.



**WARNING: HOT SURFACE**

When heating is activated, the heated ultrasonic transducers will get very hot and should not be touched.

### 1.4. User Manual Revision History

Document Version	Release Date	Key Changes
1	27/09/2023	First Release
2	22/03/2024	Updated to include heating information

# MaxiMet<sup>®</sup> Marine

## GMX560 Compact Weather Station

### 2. Product Overview and Functions

The Gill MaxiMet Marine is a very robust device with no moving parts. The units of measure, output rate and Communication formats are all user selectable.

The MaxiMet Marine can be used in conjunction with a PC, data logger or other device.

The MaxiMet Marine combines all the instrument data into a single data string. This may be configured for digital ASCII RS232/RS422/RS485 (2 wire point to point only), digital Modbus RTU/ASCII, NMEA and SDI-12 outputs.

Project Code	Model number				Wind Speed		NON-GPS/GPS/HEATED		
1957	0	5	6	0	6	0	X	X	X

logger  
or other  
device.



Non-GPS	0	0	0
GPS	1	0	0
Non-GPS (HTD)	0	0	1
GPS (HTD)	1	0	1

**Note:** HTD refers to heated Maximets

The Maximet combines all the instrument data into a single data string. This may be configured for digital ASCII RS232/RS422/RS485 (2 wire point to point only), digital Modbus RTU/ASCII, NMEA and SDI-12 outputs.

# MaxiMet<sup>®</sup> Marine

## GMX560 Compact Weather Station

### 2.1. Wind Speed and Direction Sensor

The MaxiMet Marine uses the Gill Ultrasonic WindSonic wind speed and direction sensor. The WindSonic measures the times taken for an ultrasonic pulse of sound to travel from the north (N) transducer to the south (S) transducer and compares it with the time for a pulse to travel from S to N transducer. Likewise, times are compared between west (W) and east (E), and E and W transducer.

If, for example, a north wind is blowing, then the time taken for the pulse to travel from N to S will be faster than from S to N, whereas the W to E and E to W times will be the same. The wind speed and direction can then be calculated from the differences in the times of flight on each axis.

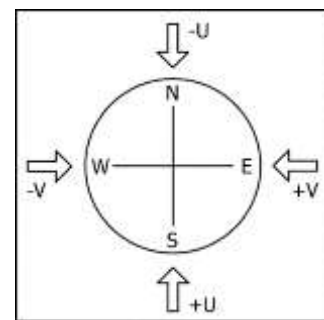
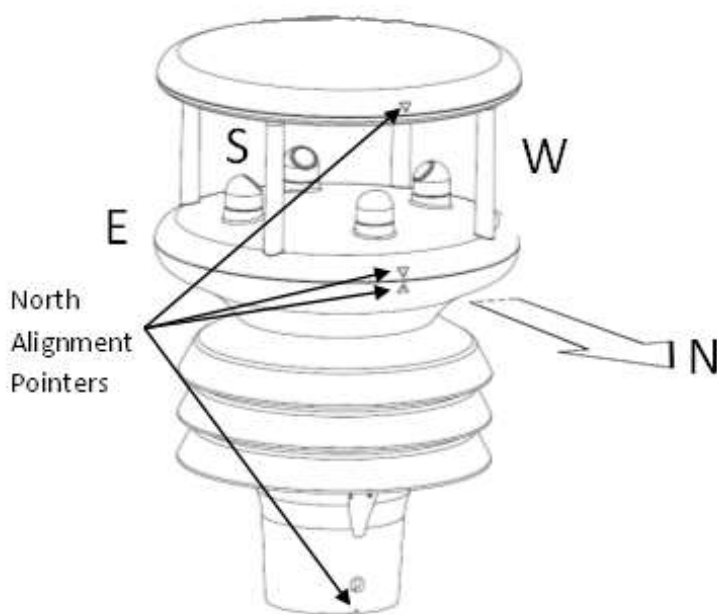

Compass points: The compass direction and polarity of U and V if the wind components along the U and V axis are blowing in the direction of the respective arrows as shown in the above diagram.

MaxiMet Marine can output the following wind readings depending on use of a Compass or GPS:

- Relative wind – wind speed and/or direction, uncorrected, but relative to the north marker, which may not be facing north.
- Corrected wind – with the aid of the Compass Magnetic North corrected wind direction can be output.
- True wind – wind speed and/or direction information corrected by GPS for any direction misalignment of the north marker and/or for any motion of the station. (E.g. vehicle or vessel).

Note: 6 axis compass only corrects for compass accuracy when the MaxiMet Marine is tilted – it does not correct measured wind direction accuracy.

### 2.2. Solar Radiation Shield

A MetSpec Multi-Plate Solar Radiation Shield is used. The special shield plate geometry, with its double louvre design, provides excellent response time performance of quick ambient temperature changes while still working effectively as a shield to stop larger contaminants such as salt or dirt from reaching the temperature and humidity sensors. The shield benefits from very robust material choice and extremely high UV protection requiring no maintenance.



# MaxiMet<sup>®</sup> Marine

## GMX560 Compact Weather Station

### 2.3. Barometric Pressure

Barometric pressure is provided by a solid-state device fitted onto a board inside a MaxiMet moulding.

### 2.4. Temperature, Relative Humidity and Dewpoint

There are internal solid state sensor circuits contained within the radiation shield that provides digital output signals for Relative Humidity, Temperature and calculated Dewpoint.

### 2.5. Compass

MaxiMet Marine uses a 6-axis compass, this comprises of a 3-axis fluxgate compass providing heading and a 3-axis accelerometer for pitch and roll data.

MaxiMet Marine uses the internal compass to electronically sense the horizontal component of the Earth's magnetic field. Information from the compass can be used to correct the Wind direction data for when the MaxiMet Marine is not aligned to North. The output of the wind direction is relative to magnetic North. The MaxiMet Marine compass is calibrated at Gill Instruments before the unit is delivered.

Prior to installing MaxiMet Marine it is suggested that for best accuracy a declination figure should be entered.

Use of the Compass-Corrected Wind Direction readings allows the unit to be installed such that accurate positioning of the MaxiMet north marker is not required.

Caution: Gill provide a derived parameter for corrected wind direction and speed information, this derived parameter is based on an algorithm devised by Gill and may not satisfy or meet other known valid standards for correcting a moving object's wind speed and direction heading. Details on the algorithm used are included in the Appendix K.

### 2.6. Compass Declination

Declination is the magnetic declination (the angle between Magnetic North and True North) in degrees. This is a correction factor that is added to the Magnetic North heading from the compass.

Map and declination figures in decimal figures can be obtained from:

- <http://www.geosats.com/magdecli.html>
- <http://www.ngdc.noaa.gov/geomag/declination.shtml>

### 2.7. GPS Option

MaxiMet Marine uses a highly accurate GPS antenna receiver module including a ceramic GPS patch antenna. The module is capable of receiving signals from up to 48 GPS satellites and transferring them into position and timing information. Small size and high-end GPS functionality are combined with low power consumption.

When GPS Speed, GPS Heading and Compass Heading are all available, Corrected Wind Speed shall be computed as the True Wind Speed.



# MaxiMet<sup>®</sup> Marine

## GMX560 Compact Weather Station

### 2.8. Inclinometer

MaxiMet Marine outputs Tilt co-ordinates X and Y in terms of degrees and Z in terms of orientation.

#### Normal Tilt Output

- X-Tilt is displayed in degrees with 2 signed integral digits over the range  $\pm 89^\circ$ .  
With respect to the MaxiMet Marine north marker:-
  - +XX indicates that the unit is tipping towards east.
  - XX indicates that the unit is tipping towards west.
- Y-Tilt is displayed in degrees with 2 signed integral digits over the range  $\pm 89^\circ$ .
  - +YY indicates that the unit is tipping towards north.
  - YY indicates that the unit is tipping towards south.
- Z-Orientation is displayed as +1 or -1.
  - +1 (normal upright position ( $\pm 90$  degrees)).
  - 1 (inverted position ( $\pm 90$  degrees)).

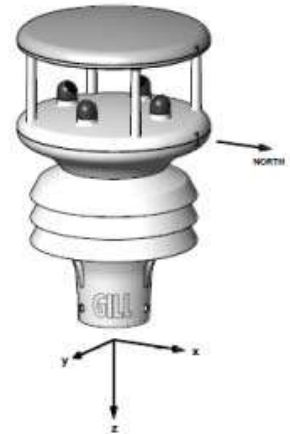

#### Check Tilt Function Output

Units with an Inclinometer have a more accurate X and Y Tilt 4Hz output that also includes compass heading (on wind output units) that can be configured with a PC terminal program during installation if required Appendix I.

- X-Tilt is displayed in degrees with up to 2 integral digits and a decimal point over the range  $\pm 89.9^\circ$ .
- Y-Tilt is displayed in degrees with up to 2 integral digits and a decimal point over the range  $\pm 89.9^\circ$ .
- Z-Orientation is displayed as +1 or -1.
- The compass reading (on wind output models) shall be output in degrees (000-359).

### 2.9. Heating Function Option

MaxiMet Marine has the additional option of a function for heating the wind sensor ultrasonic transducers.

#### Heating modes

OFF

AUTO - heating controlled by the ambient temperature sensor and the heating on/off thresholds.

- When the ambient temperature reaches the upper threshold, the heating is disabled.
- When the ambient temperature reaches the lower threshold, the heating is turned ON.
- While the heating is ON, the heating element temperature is maintained to a constant level by adjusting the heater element current draw

**Note:** As default the lower and upper thresholds are set to +5°C to +10°C. The user can configure these values using Gill's Metset software, up to a maximum value of +10°C for each threshold.

# MaxiMet® Marine

## GMX560 Compact Weather Station

### 3. Pre-Installation

#### 3.1. Equipment Supplied

- Installation kit comprising of a M12 connector (1957-PK-148) and 3 off M5 bolts and washers to bolt the unit to a mounting pole.
- MaxiMet User Manual available to download here: <https://gillinstruments.com/downloads/> (this manual).
- MetSet & MetView software available to download here: <https://gillinstruments.com/downloads/>
- Product Test Report.

#### 3.2. Optional Extras/Spares

A range of accessories is available to support MaxiMet Marine A list of accessories is shown below.

More information, and the most up to date list of accessories can be found at [gillinstruments.com](https://gillinstruments.com).

Accessory	Gill Instruments Part Number
Connector, M12, 8 way, field wireable	1957-PK-150
Cable, for power and communications, 2m with M12, 8 way over moulded connector	1957-PK-151
Cable, for power and communications, 5m with M12, 8 way over moulded connector	1957-PK-152
Cable, for power and communications, 10m with M12, 8 way over moulded connector	1957-PK-153
Cable, for power and communications, 20m with M12, 8 way over moulded connector	1957-PK-154
Cable, M12 to USB, for MaxiMet Marine set-up	1957-PK-155
Mounting Bracket	1771-PK-130

#### 3.3. MaxiMet Marine Conformity

A copy of the Declaration of Conformity can be downloaded from [gillinstruments.com](https://gillinstruments.com).

Note: This equipment has been tested and found to comply with the limits for a Class A digital device, pursuant to part 15 of the FCC Rules. These limits are designed to provide reasonable protection against harmful interference when the equipment is operated in a commercial environment. This equipment generates, uses, and can radiate radio frequency energy and, if not installed and used in accordance with the instruction manual, may cause harmful interference to radio communications. Operation of this equipment in a residential area is likely to cause harmful interference in which case the user will be required to correct the interference at his own expense.

## GMX560 Compact Weather Station

### 3.4. Right to change and revise

Gill Instruments reserve the right to change or revise the product without notice or the obligation to notify any person or organisation of such change or revision.

Gill Instruments reserve the right to change or revise the information supplied in this manual without notice or the obligation to notify any person or organisation of such change or revision.

The reproduction and distribution of the documentation and software supplied with this product and the use of its contents is subject to written authorization from Gill Instruments.

### 3.5. Packaging

Whilst the MaxiMet Marine is being moved to its installation site, the unit should be kept in its inner packaging. All the packaging should be retained for use if the unit has to be returned at any time, or if a self-test is performed.

### 3.6. Specification

The MaxiMet Marine Specification can be found in Appendix A

### 3.7. Downloadable Software

Two software packages are available to help customers use MaxiMet Marine.

- Metset - this software can be used to set-up the product
- MetView - this software can be used to view the data provided by the product

Both software packages can be downloaded from <https://gillinstruments.com/downloads/>

### 3.8. Setup Requirements

#### 3.8.1. Host System



The default delivery output communication setting of MaxiMet Marine output is RS232 with the COMMS interface setting set for RS232.

Use an RS232 to USB converter or 1.8m configuration cable fitted with 8-way M12 connector and with integral 5V USB connector power for MaxiMet Marine Gill Part No. 1957-PK-155, (see para 3.2).

If an install driver is required for this cable it can be downloaded from:

<http://www.ftdichip.com/FTDrivers.htm>

Alternatively, use:

- An RS232 to USB adaptor or equivalent, for example EasySynch part ES-U-1001-A (if not using Gill part 1957-PK-155), or connect directly to an RS232 COM port
- A PC running Windows software up to and including Windows 10 and with an internal or external interface compatible with the output from the MaxiMet Marine
- A power supply, 5V to 30V DC at 200mA, if not using the Gill Instruments Configuration cable. Please note, if heating option is turned ON a supply of 10 to 30 DC at 1.6A would be required.
- A 3 pair cable e.g. Belden 9503 (026-02660), length as required, if not using the Gill Instruments Configuration cable.

## GMX560 Compact Weather Station

### 3.8.2. Bench System Test

Prior to physically mounting the MaxiMet Marine in its final location, we strongly recommend that a bench system test be carried out to confirm the system is configured correctly, is fully functional and electrically compatible with the selected host system and cabling (preferably utilising the final cable length). The required data format, units, output rate, and other options should also all be configured at this stage.

Connect the MaxiMet Marine to a PC wired as per RS232 connections in para 5.

Alternatively use a Gill Configuration cable, Gill Part No. 1957-PK-155 with an 8-way connector fitted on one end and USB converter at the other end if required to simplify set up between MaxiMet and a PC.

Open the Gill MetSet software provided to read, check, or change settings as per Appendix D.

Use MetSet to view the data string and confirm that the Status field reads correct operation.

## 4. Installation Guidelines

### 4.1. Interference

As with any sophisticated electronics, good engineering practice should be followed to ensure correct operation.

Always check the installation to ensure the MaxiMet Marine is not affected by other equipment operating locally, which may not conform to current standards, e.g. radio/radar transmitters, boat engines, generators etc.

Do NOT mount the MaxiMet Marine in close proximity of high-powered radar or radio transmitters. A site survey may be required if there is any doubt about the strength of external electrical noise.

#### Guidelines

- Avoid mounting in the plane of any radar scanner – a vertical separation of at least 2m should be achieved.
- For radio transmitting antennas, the following minimum separations (all round) are suggested:
  - VHF IMM – 1m.
  - MF/HF – 5m.
  - Satcom – 5m (avoid likely lines of sight).
- Ensure the product is correctly earthed in accordance with this manual.
- Use cables recommended by Gill, keeping the length below the maximum allowed. Where the cables are cut and re-connected (junction boxes, plugs and sockets) the cable screen integrity must be maintained, to prevent the EMC performance being compromised.

If a screened cable is not available between MaxiMet Marine and a rain gauge connection and there are local high RF field strengths, then it is advised to route cabling through a grounded metal conduit.
- Earth loops should not be created – earth the system in accordance with wiring diagrams.
- Ensure the power supply operates to the MaxiMet Marine specification at all times.

Immunity test requirements for equipment intended to be used in an industrial electromagnetic environment have been applied. These test levels are above the levels expected to be experienced in normal use due to the above recommended siting conditions, but disturbances may be expected 150 to 200kHz. If any interruption to performance is experienced due to external electromagnetic signals the product will automatically return to specification once the signals levels have diminished.

# MaxiMet<sup>®</sup> Marine

## GMX560 Compact Weather Station

### 4.2. Wind

Avoid turbulence caused by surrounding structures that will affect the MaxiMet Marine measurement such as trees, masts and buildings.

The World Meteorological Organisation makes the following recommendations:

- The standard exposure of wind instruments over level open terrain is 10m above the ground. Open terrain is defined as an area where the distance between the sensor and any obstruction is at least 10 times the height of the obstruction.
- If mounting on a building, then theoretically the sensor should be mounted at a height of 1.5 times the height of the building.

If the sensor is to be mounted on a mast boom, part-way up a tower or mast, then the boom should be at least twice as long as the minimum diameter or diagonal of the tower. The boom should be positioned on the prevailing wind side of the tower.

It is important to ensure that the MaxiMet Marine is mounted in a position clear of any structure which may obstruct the airflow or induce turbulence.

Mount MaxiMet Marine so as to have a clear view of prevailing winds.

### 4.3. Compass

It is not possible to calibrate for changing magnetic anomalies. Thus, for greatest accuracy, keep the MaxiMet Marine away from sources of local magnetic distortion that will change with time; such as electrical equipment that will be turned on and off, or ferrous bodies that will move. Make sure that MaxiMet Marine is not mounted close to areas that may be see large sources of local magnetic fields.

Electric motors usually generate magnetic fields that are much stronger than the earth's field. It is recommended that MaxiMet Marine be moved as far away from the motors as possible.

As a guide ensure that MaxiMet Marine is mounted at least 1 metre away from ferrous objects to prevent them influencing the compass reading.

A declination correction factor can be added to the Magnetic North heading from the compass.

Map and declination figures in decimal figures can be obtained from:

<http://www.geosats.com/magdecli.html>

<http://www.ngdc.noaa.gov/geomag/declination.shtml>

## GMX560 Compact Weather Station

### 4.4. GPS

MaxiMet should be mounted horizontally and vertically as level as possible. MaxiMet Marine has a tilt sensor output that can assist with this.

A clear view of the sky is best for an optimal satellite lock. Tree canopy, surrounding hills/mountains, tall buildings and any mounting structure/mast that obscures the view either overhead or of the horizon can impede reception.

Signal multipath errors can occur if the GPS signal is reflected off objects such as tall buildings or large rock surfaces before it reaches the receiver. This increases the travel time of the signal, thereby causing errors.

Number of satellites visible - the more satellites a GPS receiver can see, the better the accuracy. Buildings, terrain, electronic interference or sometimes even dense foliage can block signal reception, causing position errors or possibly no position reading at all. GPS units typically will not work indoors or underground.

### 4.5. Tilt

Inclinometer Tilt Angle (X and Y planes, 00-89 degrees) and Orientation (Z plane, upright/inverted) can be enabled using MetSet to be output continuously at 1Hz in the data string to level the sensor horizontally.

See also page 20 Inclinometer and Tilt information.

There is also a Check Tilt function that may be enabled using a terminal program that solely outputs Tilt Angle (X and Y planes, 0-89.9 degrees) and Z information (plus a compass heading on Wind Models) at 4Hz if this level of accuracy is required. See Appendix I for set up details.

If it is required to mount the unit at an angle e.g. 30 degrees then rotate the unit so that the unit north marker points north and the X reading is +00 or -00 degrees. Whilst maintaining the X reading at 00 degrees, angle the unit so that the Y reading is +30 degrees for Northern Hemisphere Locations or -30 degrees for Southern Hemisphere Locations.

### 4.6. General Alignment

The MaxiMet Marine anemometer should be set to point north (or to another known reference direction), using the north pointers, which are identified on the instrument figure on page 6.

If the MaxiMet Marine Compass output is enabled by using MetSet (Report page, COMPASSH setting) then a direct Magnetic North compass reading can be used to set MaxiMet Marine north markers to north.

Otherwise MaxiMet Marine need not be aligned precisely if the Compass Corrected Direction (CDIR) readings are to be used.

MaxiMet Marine has a tilt sensor output that can assist with levelling the unit.

## GMX560 Compact Weather Station

### 4.8. Installing MaxiMet Marine on pipe or pole

#### End Pole Mounting Arrangement

STEP 1: Mount Adaptor (4856-30-003) to Bracket (4856-30-001) using 3 off M5 16mm screws (032-07079), 6 off M5 washers (032-07122) & 3 off M5 Nyloc nuts (032-03729). Torque tighten nuts to 3Nm+/-0.3.

STEP 2: Secure bracket and pole mount support plate (4856-30-004) to pole using 2 off supplied M6 V-Bolts (032-07120), 4 off M6 washers (032-07176) & 8 off M6 nuts (032-07121). Recommended pole Ø ranges from 25mm - 50mm, torque tighten nuts to 3Nm+/-0.3.



**Important:** Connector should be fitted to the anemometer prior to securing the anemometer to the adaptor, torque tighten the anemometer bolts to 2Nm+/-0.2.

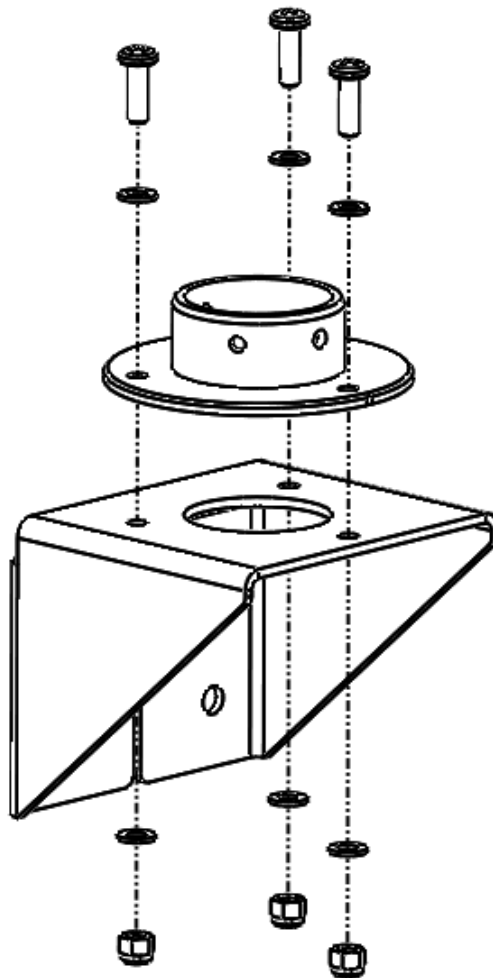

# MaxiMet® Marine

## GMX560 Compact Weather Station

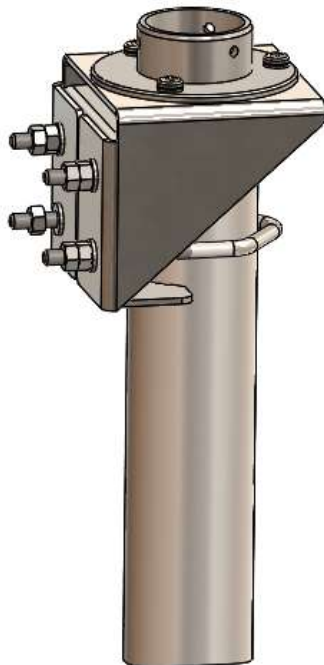
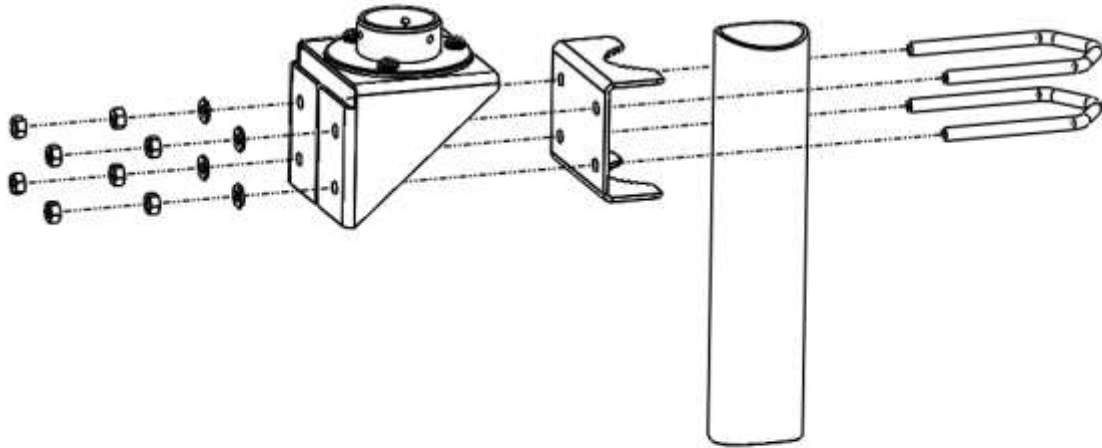



# MaxiMet<sup>®</sup> Marine

## GMX560 Compact Weather Station

### Side Pole Mounting Arrangement

STEP 1: Mount Adaptor (4856-30-003) to Bracket (4856-30-001), using 3 off M5 16mm screws (032-07079), 6 off M5 washers (032-07122) & 3 off M5 Nyloc nuts (032-03729). Torque tighten nuts to 3Nm+/-0.3.

STEP 2: Secure bracket and pole mount support plate (4856-30-004) to pole using 2 off supplied M6 V-Bolts (032-07120), 4 off M6 washers (032-07176) & 8 off M6 nuts (032-07121). Recommended pole Ø ranges from 25mm - 50mm, torque tighten nuts to 3Nm+/-0.3.



**Important:** Connector should be fitted to the anemometer prior to securing the anemometer to the adaptor, torque tighten the anemometer bolts to 2Nm+/-0.2.

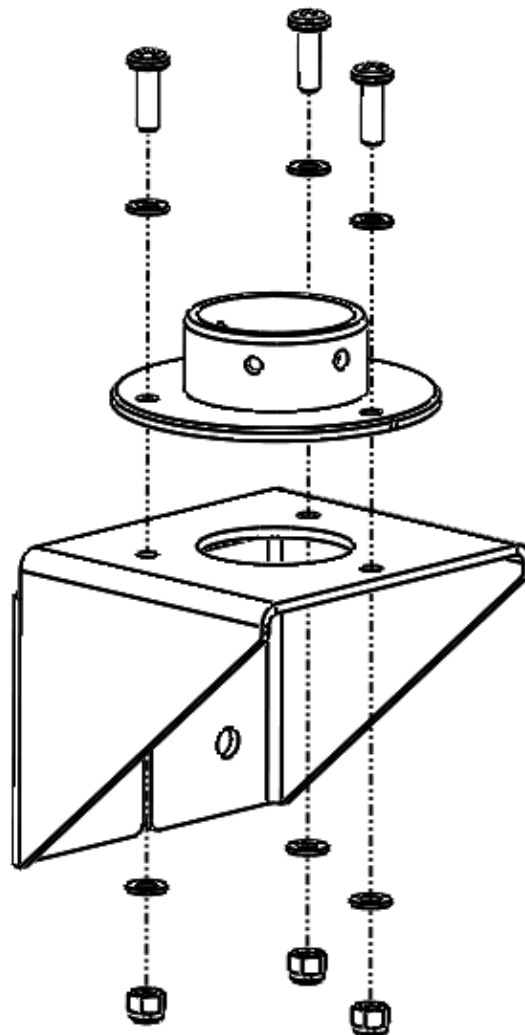

# MaxiMet<sup>®</sup> Marine

## GMX560 Compact Weather Station

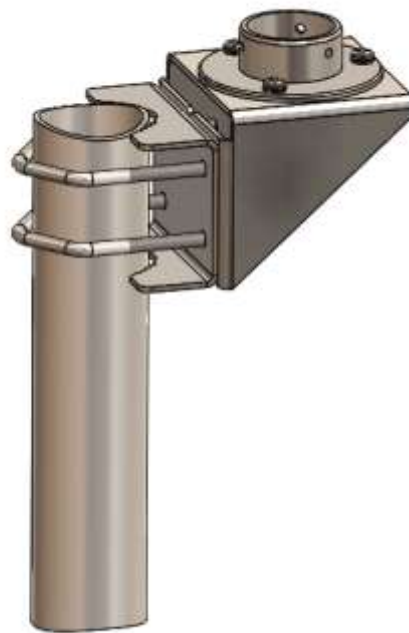
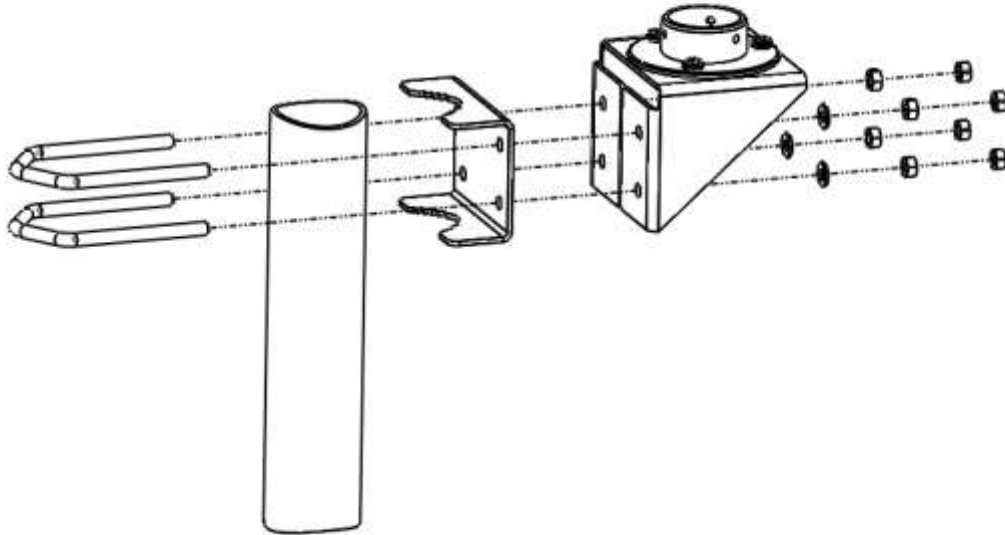

## GMX560 Compact Weather Station

---

### 4.9. Installing Cable Strain Relief

Once MaxiMet Marine has been affixed in place, all cables should be secured:

- With cable clamps or equivalent such that the connector does not support the cable weight.
- Away from the mounting bolts to prevent chafing of the cable.
- At appropriate points along the cable run/down the pole. If possible, place the cable away from the external environment, e.g. through the mounting pole.

### 4.10. Lightning Protection

To ensure correct operation and for maximum protection from lightning, a separate lightning rod system is recommended to protect the system.

# MaxiMet<sup>®</sup> Marine

## GMX560 Compact Weather Station

### 4.11. Dimensions

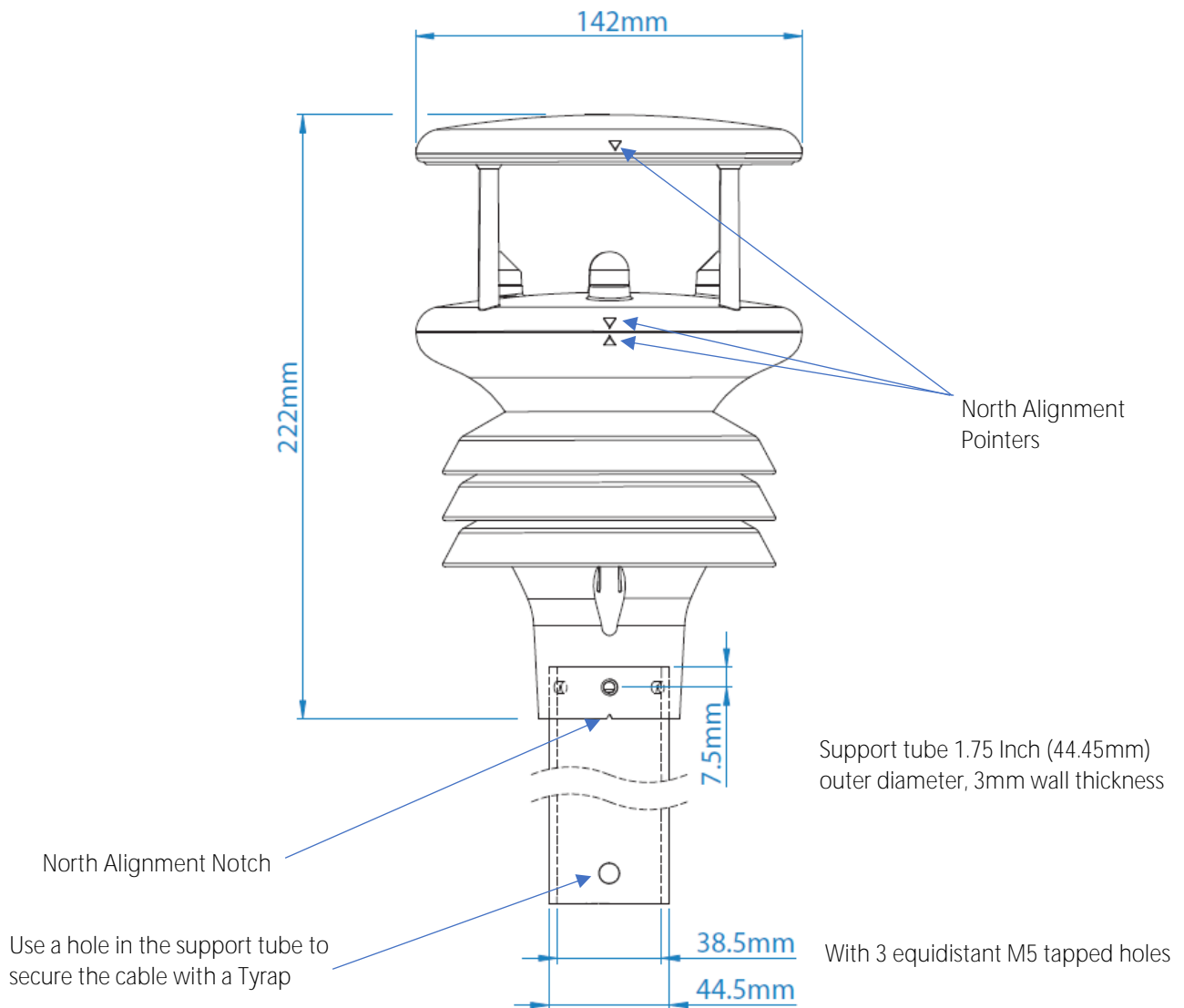

# MaxiMet® Marine

## GMX560 Compact Weather Station

### 5. Connector and pin allocation

The pin allocation for the power and communications connector is shown below.

It is recommended that:

- MaxiMet Marine default factory communications setting is RS232
- Any cable wires not used should be isolated and grounded at the terminating equipment/user end.
- Signal ground should be used in conjunction with RS422 TX/RX lines in order to improve noise immunity.
- The recommended cable length for reliable operation is limited to 6.5m (20ft)
- For longer cable runs, we recommend use of RS422 output.

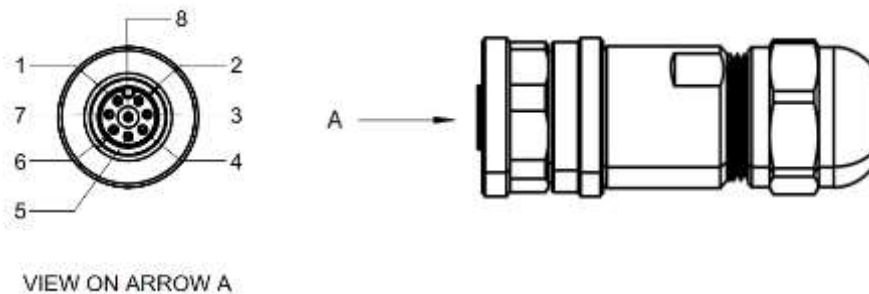

Cable colours below represent Gill supplied cable.

Pin	Wire Colour	RS-232 (Default)	RS-422	RS-485	SDI-12
1	White	Power Ground	Power Ground	Power Ground	Power Ground
2	Brown	Rx-	Rx-	Rx-	-
3	Green	-	Tx+	Tx+	-
4	Yellow	Tx-	Tx-	Tx-	-
5	Grey	-	Rx+	Rx+	-
6	Pink	Power (V+)	Power (V+)	Power (V+)	Power (V+)
7	Blue	Signal Ground	Signal Ground	Signal Ground	Signal Ground
8	Red	-	-	-	SDI-12 Signal

# MaxiMet<sup>®</sup> Marine

## GMX560 Compact Weather Station

### 6. Maintain MaxiMet

#### 6.8. Safe Mode

If the unit will not communicate, or the communication protocol settings are not known, then communications with the unit can be established using Safe Mode. Details of how to use Safe Mode can be found in Appendix H.

##### 6.8.1. Major Repairs

If the unit is more seriously damaged it can be returned for repair via a local distributor or directly to Gill Instruments.

The unit should be carefully packed in the original packaging or similar packaging to avoid any further damage. Where possible, a description of the fault, and a list of any fault codes seen, should be included.

Contact details to return a unit to Gill Instruments can be found at [gillinstruments.com](http://gillinstruments.com).

#### 6.9. Warranty Repairs

If the unit experiences issues during the warranty period, the unit should be returned to Gill Instruments together with a copy of the original invoice.

The unit should be carefully packed in the original packaging or similar packaging to avoid any further damage. Where possible, a description of the fault, and a list of any fault codes seen, should be included.

Instructions on how to return a unit to Gill Instruments can be found at [gillinstruments.com](http://gillinstruments.com).

# MaxiMet<sup>®</sup> Marine

## GMX560 Compact Weather Station

### Appendix A - Technical Specification

Wind Measurement	
Parameters	Polar Wind Speed & Direction or U and V Vectors
Wind Speed	
Range	0.01 to 60m/s
Accuracy	0-10 m/s 0.3 m/s RMSE 10-40 m/s 3% RMSE 40-60 m/s 5% RMSE
Resolution	0.01m/s
Threshold	0.01m/s
Units of Measurement	Metres/Sec, Knots, Miles/Hour, Kilometres/Hour, Feet/minute.
Wind Direction	
Range	0-359 Degrees – No dead band
Accuracy	0.5 m/s-40 m/s $\pm 3^\circ$ 40-60 m/s $\pm 5^\circ$
Resolution	1°

Air Temperature	
Range	-40°C to +70°C with heating
Accuracy	$\pm 0.3^\circ\text{C}$ @ 20°C
Resolution	0.1°C
Units of Measure	°C or °F or °K

Relative Humidity	
Range	0-100%
Accuracy	Typically $\pm 2\%$ RH across full range
Resolution	1%
Units of Measure	%, Rh, g/m <sup>3</sup>

Dewpoint	
Range	-40°C to +70°C
Resolution	0.1°C
Units of Measure	°C or °F or K
Sampling rate	1Hz

Barometric Pressure	
Range	300-1250 hPa
Accuracy	Absolute (typically) $\pm 0.4$ hPa Relative (typically) $\pm 0.08$ hPa
Resolution	0.1hPa
Units of Measure	hPa, mbar, mmHg, InHg

# MaxiMet<sup>®</sup> Marine

## GMX560 Compact Weather Station

GPS	
Horizontal Position accuracy	Less than 2.5m Circular Error Probability (Selective Availability Off)
Time to fix	Less than 45 seconds from unit power up when stationary
Channels	48
Accuracy	Longitude and latitude report to 6 decimal places
GPS Time Update	Allow 1 hour upon switch on for GPS time update

Real Time Clock	
Format Date and Time	YYYY-MM-DDThh:mm:ss.s, e.g. 2014-12-25-T22:34:56.1
Updating	Manual setting or via GPS option
Power Loss Accuracy	±10 seconds for at least 24 hours after power removed from MaxiMet

Compass	
Range	0-359°
Resolution Compass Heading	1°
Units of Measure	Degrees

Inclinometer	
X Tilt	±89 degrees
Y Tilt	±89 degrees
Z Orientation	+1 Upright, -1 Inverted
Resolution	X-Tilt and Y-Tilt measurements have a resolution of 1 degree
Accuracy	Tilt accuracy ±3° for X-Tilt, Y-Tilt and Z-Orientation
Check Tilt Mode	X, Y and Z output only
X and Y Tilt in Check Tilt Mode	±89.9 degrees, 4 Hz Output

Outputs	
Digital Outputs	Gill ASCII RS232, RS422, RS485* or SDI-12. (RS232 point to point and RS485 2 wire networkable – Modbus RTU/ASCII). Gill ASCII output is 8 bit, No Parity and 1 stop bit.
Baud Rates	1200 (SDI-12), 4800-57600 (ASCII RS232, RS422, RS485*) 9600-19200 (Modbus RTU/ASCII)
Protocols	ASCII, SDI-12 V1.3, NMEA 0183 or Modbus RTU/ASCII
Data Output	1 reading per second (1 Hz), 1 reading per minute, 1 reading per hour or Polled Mode
MaxiMet Status	Status codes provided within the data message string



# MaxiMet® Marine

## GMX560 Compact Weather Station

Power Supply	
Input Voltage (RS232, RS422, RS485)	5V to 30V DC 10 to 30VDC (with heating)
Average Current at 12V DC with Power Saving Mode disabled (default)	24mA For GPS-enabled units allow for an additional 10mA For Heated enabled units allow for 400mA
Average Current at 12V DC in Power Saving Mode and output a reading once per hour	GMX560 – 0.7mA For GPS-enabled units allow for an additional 6mA

Environmental	
Protection Class	IP66 & IP68 rated (1 metre for 1 hour)
Operating Temperature	-35°C to +70°C (Without heating) -40°C to +70°C (With heating)
CE Marking	Yes
Origin	UK

Options	
GPS	Available as an option. Enables reporting of location, height, real-time clock, true wind (for vehicle mounting applications)
Heating	Available as an option for operation where frost & ice accumulation on transducers is possible

Mechanical	
External Construction	Polycarbonate
Fittings	Bolt fittings supplied for securing the unit to a vertical pipe of diameter 44.45mm
Overall Dimensions	142mm x 142mm x 142mm
Weight	0.4kg

# MaxiMet<sup>®</sup> Marine

## GMX560 Compact Weather Station

### Appendix B - Default Configuration

Factory Default Data String

Items in red relate to the GPS option unit.

Items in green relate to Heater option unit.

NODE, DIR, SPEED, CDIR, CSPEED, PRESS, RH, TEMP, DEWPOINT, GPSLOCATION, TIME, VOLT, HEATSTAT, STATUS, CHECK

␣Q,021,000.01,090,000.01,1015.3,041, +022.0, +008.5, +50.763004:-001.539898:+3.10,2015-06-05T10:19:30.8,+05.1,0000,0004, L 36

Where

␣	STX
Q	Node Letter
021	Wind Direction
000.01	Wind Speed
090	Corrected Direction
000.01	GPS Corrected Speed
1015.3	Pressure
041	Relative Humidity
+022.0	Temperature
+008.5	Dewpoint
+50.763004	GPS Latitude
-001.539898	GPS Longitude
+3.10	GPS Height location
2015-06-05	Date
T10:19:30.8	Time
+05.1	Supply Voltage
0000	Heater Status
0004	Status
L	ETX
36	Checksum



<STX> is the Start of String character (ASCII value 2).

<ETX> is the End of String character (ASCII value 3).

Checksum, the 2 digit Hex Checksum sum figure is calculated from the Exclusive OR of the bytes between (and not including) the STX and ETX characters.

# MaxiMet® Marine

## GMX560 Compact Weather Station

### MetSet Default Settings

REPORT : NODE DIR SPEED CDIR CSPEED PRESS RH TEMP DEWPOINT GPSLOCATION TIME VOLT STATUS CHECK		
PROTOCOL : GILL	SENSOR COMPASS : ON	POWER : 0
COMMS : RS232	COMPASSDECL : +000.0	TIME : 2015-06-05T11:04:54
BAUD : 19200	SENSOR GPS : ON	AUTOTIME : ON
NODE : Q	UNITS GPS : MS	TZOFFSET : +00.00
OUTFREQ : 1HZ	SENSOR TEMP : ON	PUPMSG STATUS : ON
MSGMODE : CONT	UNITS TEMP : C	PUPMSG REPORT : ON
ASCTERM : CRLF	SENSOR DEWPOINT : ON	PUPMSG UNITS : ON
ECHO : ON	UNITS DEWPOINT : C	MODBUS : RTU
ALIGN : 0	SENSOR PRESS : ON	MODADDR : 1
SENSOR WIND : ON	UNITS PRESS : HPA	DATABITS : 8
UNITS WIND : MS	HASL : +00000.00	STOPBITS : 1
NODIR : 0.00	HASTN : +00000.00	PARITY : NONE
AVGSHORT : 60	SENSOR RH : ON	MODTERM : 10
AVGLONG : 10	UNITS RH : %	MODICT : 1000

### Full Data String:

#### Non GPS

Node, Relative Wind Direction, Relative Wind Speed, Corrected Wind Direction, Average Relative Wind Direction (WMO), Average Relative Wind Speed (WMO), Relative Gust Direction (WMO), Relative Gust Speed (WMO), Wind Sensor Status, Pressure, Pressure at Sea level, Pressure at Station, Relative Humidity, Temperature, Dewpoint, Absolute Humidity, Compass Heading, Pitch, Roll, Wind Chill, Heat Index, Air Density, Wet Bulb Temperature, X-Tilt, Y-Tilt, Z-Orientation, User Information Field, System Date and Time, Supply Voltage, Heater Status, Status, Checksum

Q,301,000.09,305,000.09,000,000.00,000,000.00,000,000.00,0100,1023.8,1023.8,1023.8,042,+021.9,+008.6,08.24,+004.3,+01.4,+00.3,273,000.00,0105,,,1.2,+014.3,03:58,12:03,20:08,111:+44,20:52,21:55,,+00,+00,+1,,2023-06-01T08:59:01.9,+04.9,0000,0004,18

## GMX560 Compact Weather Station

### GPS

Node, Relative Wind Direction, Relative Wind Speed, Corrected Wind Direction, Corrected Wind Speed, Average Relative Wind Direction (WMO), Average Relative Wind Speed (WMO), Relative Gust Direction (WMO), Relative Gust Speed (WMO), Average Corrected Wind Direction (WMO), Average Corrected Wind Speed (WMO), Corrected Gust Direction (WMO), Corrected Gust Speed (WMO), Wind Sensor Status, Pressure, Pressure at Sea level, Pressure at Station, Relative Humidity, Temperature, Dewpoint, Absolute Humidity, Compass Heading, Pitch, Roll, GPS Location, GPS Heading, GPS Speed Over Ground, GPS Sensor Status, Wind Chill, Heat Index, Air Density, Wet Bulb Temperature, X-Tilt, Y-Tilt, Z-Orientation, User Information Field, System Date and Time, Supply Voltage, Heater Status, Status, Checksum

```
7Q,301,000.01,180,000.08,000,000.00,000,000.00,000,000.00,000,000.00,0100,0998.9,0998.9,0998.9,  
040,+023.1,+009.0,08.43,058,-09.3,+49.8,+50.763112:-001.540188:-0011.90,354,000.09,010B,,,1.2,+014.9,  
08:01,12:15,16:28,170:+17,17:06,17:47,18:26,+00,+00,+1,,2018-01-16T11:33:05.7,+05.0,0000,0004,L.67
```

# MaxiMet<sup>®</sup> Marine

## GMX560 Compact Weather Station

### Appendix C - Summary of MaxiMet Derived Parameters

GMX 560 Sensor Parameter	
Wind Speed, Relative	
Wind Direction, Relative	
Compass, Heading	
Temperature, Air	
Humidity, Relative	
Barometric Pressure	
GPS (option)	Opt
GMX 560 Derived Parameter	
Average Speed (WMO)	
Average Direction (WMO)	
Average Corrected Direction (WMO)	
Corrected Direction	
Gust Direction (WMO)	
Gust Speed (WMO)	
Status (Sensors)	
Wind Status	
Dewpoint	
Absolute Humidity	
Pressure at Sea Level	
Pressure at Station	
Wind Chill	
Heat Index	
Air Density	
Wet Bulb Temperature	
Angle of Tilt	
Node Letter	
Volts (Supply)	
Time (and Date)	
Corrected Speed	GPS Opt
Average Corrected Speed (WMO)	GPS Opt
Corrected Gust Speed	GPS Opt
Corrected Gust Direction	GPS Opt
GPS Location (Longitude/latitude)	GPS Opt
GPS Heading	GPS Opt
GPS Speed	GPS Opt
GPS Status	GPS Opt

# MaxiMet® Marine

## GMX560 Compact Weather Station

### Appendix D - Configuring MaxiMet with MetSet

Install MetSet software (V2.17.01 or higher) on to a PC from the Gill website at:

<http://gillinstruments.com/main/software.html>

Before you use MetSet check that MaxiMet Marine is correctly connected to a serial COM port or USB COM port on your PC (maximum COM port number accepted by MetSet is 50).

The optional Gill 1.8m, RS232 to USB cable (Gill Part No. 1957-PK-155) can be used to power and provide a suitable communication link for configuring a MaxiMet Marine unit.



MetSet is compatible with RS232 and RS422 connected units with ASCII and NMEA outputs only.

Use Safe Mode if connected to units set for SDI-12 or Modbus outputs to read/change settings.

#### Opening MetSet

Click on the MetSet button on your PC's desktop or choose Start > All Programs > MetSet > MetSet

The MetSet Control Centre window is displayed. If you have more than one MaxiMet Marine connected to your PC, MetSet, by default, selects the first device detected.

For most applications it is recommended to click on the MetSet Connect and Read button.

MetSet interrogates the MaxiMet Marine and returns a summary of the device settings.



Figure 1 - Opening MetSet

# MaxiMet<sup>®</sup> Marine

## GMX560 Compact Weather Station



MetSet also saves a copy of the screen below as a Session Report File that can be accessed at the following destination: C:\GillAppsData\Metset\SessionReports.

Example Summary of MaxiMet Device Settings

```
GILL Summary of Device Settings
SETTINGS ARE AS FOLLOWS:

PROTOCOL : GILL
COMMS : RS232
(BAUD) : 19200
NODE : Q
OUTFREQ : 1HZ
MSGMODE : CONT
ASCTERM : CRLF
ECHO : ON
ALIGN : 0
SENSOR WIND : ON
UNITS WIND : MS
NODIR : 0.00
AVGSHORT : 60
AVGLONG : 10
PERGUST : 1
RAVGUST : 3
SENSOR COMPASS : ON
COMPASSDECL : +000.0
SENSOR TEMP : ON
UNITS TEMP : C
SENSOR DEWPOINT : ON
UNITS DEWPOINT : C
SENSOR PRESS : ON
UNITS PRESS : HPA
HASL : +000000.00
HASTN : +000000.00
SENSOR RH : ON
UNITS RH : %
REPORT : HEATSTAT
POWER : 0
TIME : 2024-01-22T15:47:39
TZOFFSET : +00.00
LAT : +51.480000
LONG : +000.000000
USERINF :
SENSOR TILT : ON
PUPMSG STATUS : ON
PUPMSG REPORT : ON
PUPMSG UNITS : ON
MODBUS : RTU
MODADDR : 1
DATABITS : 8
STOPBITS : 1
PARITY : NONE
MODTERM : 10
MODICT : 1000
HEATING : OFF
HEATINGLOW : +05.00
HEATINGHIGH : +10.00

Note changes to ANEM, BAUD, COMMS or PROTOCOL settings
will take place after next power-up.
```

Close

# MaxiMet<sup>®</sup> Marine

## GMX560 Compact Weather Station



Changes to BAUD, COMMS or PROTOCOL settings will take place after the next power-up.

Click on the Close button to continue to the MetSet set up screen.

When connected correctly a MetSet editing screen is available to read configuration settings, change configuration settings, save MaxiMet Marine configuration settings to a PC file location, upload MaxiMet Marine configuration settings from a PC file and view the MaxiMet Marine raw data string output.

MetSet Editing Screen

MetSet Configuration Software v2.16-01

**GILL MetSet**

Comms | ASCII\_Setup | Wind | Compass\_GPS | Temperature | Pressure | Humidity | Reporting | System | Power Up | MODBUS

Protocol: GILL ⚠️  
Interface: RS232 ⚠️  
Baud Rate: 19200 ⚠️  
Node ID: Q ?  
Output rate: 1Hz ?  
Message Mode: CONT ?

Write Settings | Read Settings  
Load Setup | Save Setup  
Backup Device Setup | Restore Device Setup  
Main Menu  
About/Help

Source: Defaults | S/N: 23160042 | 19200 COM4  
MAXIMET GMX560-50-00D5 | S/W ver: 2669-2.00.24  
Protocol ver: 5

Source of MetSet data | Model number | Serial number | Connectio

Move mouse over exclamation or question marks to read setting comment.

Return to opening MetSet screen

View MaxiMet raw data output string

MaxiMet device setting options



# MaxiMet<sup>®</sup> Marine

## GMX560 Compact Weather Station

### MetSet Connection Status Information

Reading	Function
ONLINE	ONLINE in green indicates the MaxiMet has been successfully connected to MetSet. OFFLINE in grey indicates that MetSet is being used without a MaxiMet in communication with MetSet.
4800 COM23	4800 is a report on the MaxiMet baud rate setting. COM 23 is a report on the MaxiMet COM port connection number.
S/W ver: 2669-2.00.24	2669 is the MaxiMet firmware number. 2.00.24 is the firmware revision.
Protocol ver: 4	4 is the protocol version (Gill internal reference).
Source: Device	MetSet reads 'Device' when the source of the data that MetSet has retrieved has come from the MaxiMet and the MaxiMet Model. MetSet reads 'File' when the source of data has come from a saved file. MetSet reports on the connected MaxiMet device

### MetSet Online Settings



Online Mode Buttons	Function
Write Settings	MetSet configuration settings are saved to a connected MaxiMet.
Read Settings	MetSet retrieves the MaxiMet configuration settings
Load Setup	When selected MetSet retrieves a MetSet edit PC file and updates MetSet with these settings.
Save Setup	When selected MetSet edit settings are saved to a PC file location.
Back Up Device Setup	When selected the MaxiMet configuration settings are transferred to MetSet and then to a file location selected on a PC.
Restore Device Setup	When selected MetSet retrieves a MaxiMet configuration setting from a PC file, loads it into the MaxiMet and updates the MetSet edit settings.
View Output	Click on View Output to view the raw ASCII MaxiMet data string scrolling at the output rate. (View only feature). E.g. Q,127,000.03,000,2000-01-01T00:40:50.2,+10.5,0000, 21
Main Menu	Click here to go back to the opening MetSet screen

# MaxiMet<sup>®</sup> Marine

## GMX560 Compact Weather Station

### MetSet Editing Pages



Items shown in bold are the default settings.

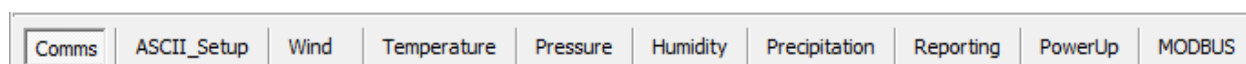

### Comms

Protocol	GILL	
Interface	RS232	
Baud Rate	19200	
Node ID	Q	
Output rate	1HZ	
Message Mode	CONT	

- Protocol:** GILL, MODBUS or SDI-12  
(for SDI-12 also set MetSet Comms/Interface to SDI-12)
- Interface:** RS232, RS422, RS485P2W (point to point) & SDI-12
- Baud Rate:** 4800, 9600, 19200, 38400 or 57600  
(1200 auto selected with SDI-12 setting)
- Node ID:** A to P, Q to Z
- Output Rate:** 1Hz (1 per second), once per minute, once per hour
- Message Mode:** CONT (continuous output) or POLL (polled mode)



When Comms or Baud Rate settings are changed and saved to the device a warning is issued by MetSet. These setting changes will not become active until the MaxiMet Marine power is turned off and turned on again. The connecting device will then also need its Comms and Baud Rate settings changed to match the MaxiMet Marine.

When selecting Modbus, Message Mode must be set for CONT.

Gill ASCII output is always fixed formatted for 8 Start bits, No Parity and 1 Stop bit.

When the output rate is set to once per minute or once per hour, wind averaging is disabled.

# MaxiMet<sup>®</sup> Marine

## GMX560 Compact Weather Station

### ASCII Setup

Comms	ASCII_Setup	Wind	Temperature	Pressure	Humidity
Termination	<input type="text" value="CRLF"/>		<input "="" type="button" value="?"/>		
Echo	<input type="text" value="ON"/>		<input "="" type="button" value="?"/>		

Termination: CRLF or CR

Echo: ON or OFF

### Wind

Comms	ASCII_Setup	Wind	Temperature	Pressure	Humidity
North Alignment	<input type="text" value="0"/>		<input "="" type="button" value="?"/>		
Sensor Windspeed	<input type="text" value="ON"/>		<input "="" type="button" value="?"/>		
Wind speed Units	<input type="text" value="MS"/>		<input "="" type="button" value="?"/>		
No-Direction Wind Speed	<input type="text" value="0.00"/>		<input "="" type="button" value="?"/>		
Short Term Average	<input type="text" value="60"/>		<input "="" type="button" value="?"/>		
Long Term Average	<input type="text" value="10"/>		<input "="" type="button" value="?"/>		
Compass Sensor	<input type="text" value="ON"/>		<input "="" type="button" value="?"/>		
Compass Declination	<input type="text" value="+000.0"/>		<input "="" type="button" value="?"/>		
GPS Sensor	<input type="text" value="ON"/>		<input "="" type="button" value="?"/>		
GPS Speed Units	<input type="text" value="MS"/>		<input "="" type="button" value="?"/>		

North Alignment: 0-359 degrees

Sensor Windspeed: ON or OFF

Wind Speed Units: MS, KTS, MPH, KPH, FPM

(Metres/Second, Knots (Nautical Miles/Hour), Miles/Hour, Kilometres/Hour, Feet/Minute)

No-Direction Wind Speed: 0.00m/s to 5.00m/s

Wind speed above which direction readings are output.

Short Term Average: 60 (10-60)

Configures WMO Short Term Average as the defined multiple of the output rate i.e. AVGSHORT 10 is a rolling average of the last ten outputs.

# MaxiMet<sup>®</sup> Marine

## GMX560 Compact Weather Station

---

Long Term Average:	10 (1-10)
	Configures WMO Long Term Average as the defined multiple of the Short Term Average i.e. if AVGSHORT is 10 and AVGLONG is also 10, Long Term Average is a rolling average of the last 100 outputs.
Compass Sensor:	ON or OFF
	With Compass Sensor ON, Wind Direction readings corrected to Magnetic North are output in the data string (CDIR). If set to OFF, the field with Compass Corrected Direction reading is left blank.
Compass Declination:	+000.0
	Declination is the magnetic declination (the angle between Magnetic North and True North) in degrees. This is a correction factor that is added to the Magnetic North heading from the compass. Map and declination figures in decimal figures can be obtained from:  <a href="http://www.geosats.com/magdecli.html">http://www.geosats.com/magdecli.html</a> <a href="http://www.ngdc.noaa.gov/geomag/declination.shtml">http://www.ngdc.noaa.gov/geomag/declination.shtml</a>
GPS Sensor:	ON or OFF (for GPS sensor output option units)
GPS Speed Units:	MS, KTS, MPH, KPH, FPM

# MaxiMet<sup>®</sup> Marine

## GMX560 Compact Weather Station

### WMO Average Wind Reading Notes



WMO averaged wind readings are disabled in MaxiMet Marine power saving mode.

When the output rate is set to once per minute or once per hour, wind averaging is disabled.

The default output rate from MaxiMet Marine is one new reading every second. In this case the WMO averaged wind reading result will be based on:

$$\text{Long Term Average (1 – 10)} \times \text{Short Term Average (10 – 60)}$$

The direction and magnitude outputs are derived from the vector sum of U and V over the RWALONG averaging period (default 10 minutes with 1Hz output rate).

The gust output is derived from the vector sum of U and V over 3 readings (3 seconds with a 1 Hz output rate), and the max gust is the maximum of the gust value over the RWASHORT period (default 60 seconds with a 1Hz output rate). The max gust value is reset to zero at the end of each RWASHORT period.

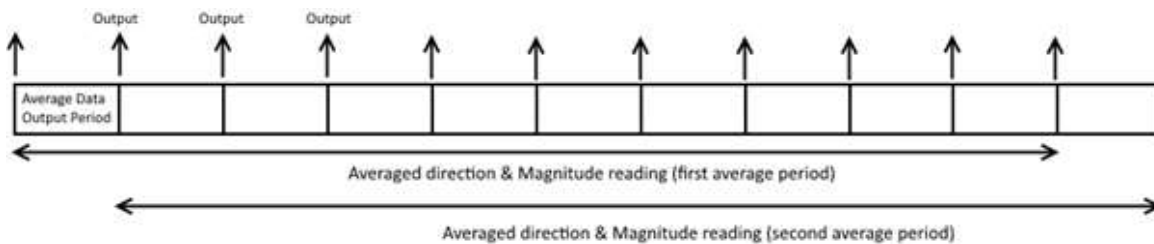

RWA Default Settings:

Output rate (Hz): 1  
RWASHORT: 60  
RWALONG: 10

Therefore, MaxiMet Marine output period =  $60/1 = 60$  seconds (the MaxiMet Marine will output a reading every 60 seconds).

Averaged direction and magnitude reading =  $10 \times 60 = 600$  seconds (this is the time the readings will be averaged over).

When the average building period has been completed, the average reported thereafter will be a rolling average derived from the last averaged direction and magnitude time period.

For instance, if a 2-minute averaged data output was required set:

RWALONG: 2  
RWASHORT: 60

For these settings, every minute you would get an averaged output reading based on the previous 2 minutes of wind data.

# MaxiMet® Marine

## GMX560 Compact Weather Station

For instance if a 10 minute averaged data output was required set:

RWALONG: 10  
RWASHORT: 60

For these settings, every minute you would get an averaged output reading based on the previous 10 minutes of wind data.

To enable WMO averaged Wind readings in the MaxiMet data string select the Reporting Tab/USERDEF and add new reporting field from the drop down menu called:

AVGSPEED Outputs Average Speed readings  
AVGDIR Outputs Average Direction readings  
AVGCDIR Outputs Average Corrected Direction readings

The maximum Gust Speed is the magnitude of the maximum gust measured over the short term output period. Gust is generated from a rolling 3s average of the short term output period, and reset at the end of short term output period.

GSPEED Outputs Maximum Wind Gust Speed

The maximum Gust Direction is the direction of the maximum gust measured over the short term output period. Gust is generated from a rolling 3s average of the short term output period, and reset at the end of short term output period.

GDIR Outputs Maximum Wind Gust Direction

Whenever the unit is powered up then until the unit has reached its minimum long term averaging interval the Wind Status Code will read 0100 (Measurement Average Building).

If MaxiMet Marine is in polled mode then when polled (default 1Hz output) MaxiMet Marine will output the last valid 10-minute wind speed and direction average, updated every minute along with last valid 1 minute gust magnitude, due to default WMO settings.

In polled mode, the last set of computed WMO measurements shall be output on receipt of a poll request. Whilst a new WMO average is building, the last computed WMO average shall be output.

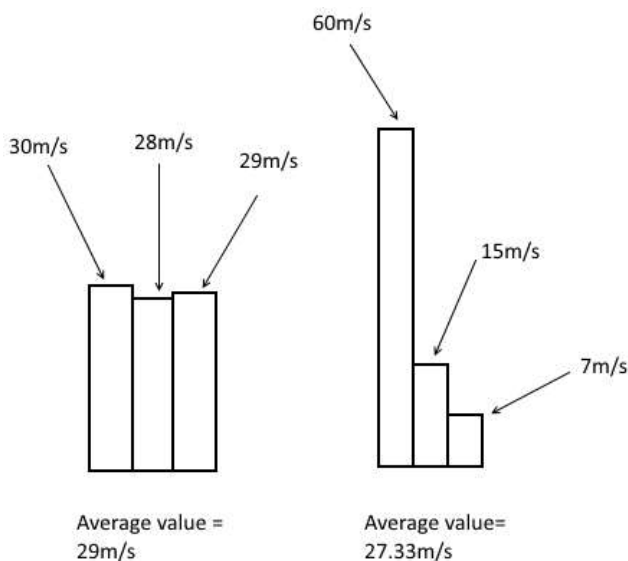

Two gust events are observed within one average data output period. The first produces an average value of 29m/s, the second an average value of 27.33m/s. The event with the highest average value is the one that the MaxiMet will output, which in this case would be the average value from the first event, even though the peak gust was higher during the second event.

# MaxiMet<sup>®</sup> Marine

## GMX560 Compact Weather Station

### Temperature

Comms	ASCII_Setup	Wind	Temperature	Pressure	Humidity
			Temperature Sensor	ON	?
			Temperature Units	C	?
			Dew point Sensor	ON	?
			Dew point units	C	?

Temperature Sensor:	ON or OFF
Temperature Units:	C, K or F (Centigrade, Kelvin, Fahrenheit)
Dew Point Sensor:	ON or OFF
Dew Point Units:	C, K or F

### Pressure

Comms	ASCII_Setup	Wind	Temperature	Pressure	Humidity
			Pressure Sensor	ON	?
			Pressure Units	HPA	?
			Height Above Sea Level	+00000.00	?
			Height Above Station	+00000.00	?

Pressure Sensor:	ON or OFF
Pressure Units:	HPA, MB, MMHG, INHG (Hectopascals, Millibars, Millimetres Mercury, Inches Mercury).
Height Above Sea Level:	+00000.00 (0 to 10000 metres)

Elevation (on the ground) of the unit relative to the average sea level point.

Atmospheric pressure varies with height above sea level as well as with atmospheric conditions. As the altitude at which the pressure sensor operates is usually constant (the station height), a correction is made to make the reading of the pressure sensor seem as if it were made at sea level. This means that the pressure reading has to be slightly increased from the value read by the MaxiMet sensor situated above sea level (often known as the station pressure).

Height Above Station:	+00000.00 (-100 to +100 Metres)
-----------------------	---------------------------------

The user can set the HASL figure together with the HASTN figure to allow pressure at sea level to be calculated.

# MaxiMet<sup>®</sup> Marine

## GMX560 Compact Weather Station

### Humidity

Comms | ASCII\_Setup | Wind | Temperature | Pressure | Humidity

Humidity Sensor: ON

Humidity Units: %

Humidity Sensor: ON or OFF

Humidity Units: %

### Reporting

Comms | ASCII\_Setup | Wind | Temperature | Pressure | Humidity | Precipitation | Reporting

Report Format: USERDEF

Report Format: USERDEF, DEFAULT, FULL or NMEA

Report Format: USERDEF

**NODE DIR SPEED CDIR CSPEED PRESS RH TEMP DEWPOINT GPSLOCATION TIME VOLT STATUS**

Select Parameters to Report

NODE DIR SPEED CDIR CSPEED PRESS RH TEMP DEWPOINT

Report Format: USERDEF

Report Format: USERDEF



## GMX560 Compact Weather Station

### Select Parameters to Report.

DEFAULT	Sets the unit to report the factory set output parameters
FULL	Sets the unit to output every available sensor and derived parameter output
NMEA	Sets the unit to output an NMEA data string
USERDEF	Report parameters can be selected in any order or switched on or off in USERDEF setting
NODE	Outputs a Node letter (A to Z)
SPEED	Outputs Wind Speed readings
CSPEED	Outputs Corrected Speed if a GPS option is enabled.
GSPEED	Outputs WMO Gust Speed
CGSPEED	Corrected Gust Speed if a GPS option is enabled.
AVGSPEED	Outputs WMO average speed reading based on AVG Short and AVG Long settings.
AVGCSPEED	Outputs WMO average corrected speed reading using GPS based on AVG Short and AVG Long settings
DIR	Outputs Wind Direction readings
CDIR	Outputs Compass Corrected Wind Direction readings
GDIR	Outputs WMO Gust Direction
CGDIR	Compass Corrected WMO Gust Direction
AVGDIR	Outputs WMO average direction reading based on AVG Short and AVG Long settings
AVGCDIR	Outputs WMO average compass corrected direction reading based on AVG Short and AVG Long settings
PRESS	Outputs the Barometric Pressure reading
PASL	Outputs Barometric Pressure at Sea Level if HASL figure set (see page 90)
PSTN	Outputs Barometric Pressure at Station if HASTN figure set (see page 90)
RH	Outputs Relative Humidity reading
AH	Outputs Absolute Humidity
TEMP	Outputs the Temperature reading
DEWPOINT	Outputs the Dewpoint reading
WCHILL	Outputs the Wind Chill value when Temperature is below 10°C and Wind Speed is at least 1.5m/s
HEATIDX	Outputs the Heat Index value when Temperature is above 75°F
AIRDENS	Outputs the Air Density value
WBTEMP	Outputs the Wet Bulb Temperature
XTILT	Tilt in X axis
YTILT	Tilt in Y axis
ZORIENT	Orientation (upright/inverted)
COMPASSH	Compass Heading direction reading
PITCH	Outputs Pitch of sensor
ROLL	Outputs Roll of sensor
GPSHEADING	Outputs a GPS direction heading
GPSSPEED	Outputs a GPS speed over ground
GPSLOCATION	Outputs Longitude, Latitude and GPS height
GPSSTATUS	Outputs a location fix and the number of viewable satellites
TIME	Outputs MaxiMet Date and Time
VOLT	Outputs the MaxiMet Supply Voltage
STATUS.	Outputs the MaxiMet Sensors Status Code (see Appendix L p83)
WINDSTAT	Outputs Status Codes relating to Wind Sensor Data (see Appendix L p83)
USERINF	User Information up to 16 characters, excludes "@", ",", ":", "%", and "?"

## GMX560 Compact Weather Station

### System

Comms	ASCII_Setup	Wind	Temperature	Pressure	Humidity	Solar	Reporting	System
Power Mode			0					?
Date Time			2015-06-17T07:33:16					?
Update System time from GPS			ON					?
Time Offset			+00.00					?
Latitude			+50.758500					?
Longitude			-001.541900					?
User information			CAL DUE 15.08.17					?

Power Mode: 0 or 1

0 is the default normal power operation mode

1 is a power-saving mode and with this set then the unit will make one reading only at the output rate whether in polled mode or continuous mode. For lowest power set the unit for 1 output reading per hour.



Power Saving Mode (1) is not applicable to NMEA, SDI-12 or Modbus outputs.  
In Power Saving Mode, Average Wind Data cannot be calculated.

Date Time: Set/read system Date/Time (YYYY-MM-DDTHH:MM:SS).  
See Appendix J p68 for more accurately setting Date/Time.

Update System time from GPS: ON/OFF

If a GPS unit is enabled, then UTC time is applied. Allow an hour for the GPS time to update after switching on.

Time Offset: +00.00  
GPS UTC time offset (range -24.00 to +24.00 hrs)

Latitude: If using solar units for which Sunrise, Sunset and other related parameters are needed then enter the installation location Latitude.

Longitude: If using solar units for which Sunrise, Sunset and other related parameters are needed then enter the installation location Longitude.

User Information: Sets the User Information field shall have a maximum size of 16 characters, comprised of printable ASCII characters (to exclude "@", ",", "\*", "% and "?").



# MaxiMet<sup>®</sup> Marine

## GMX560 Compact Weather Station

### MODBUS

Comms	ASCII_Setup	Wind	Temperature	Pressure	Humidity	Precipitation	Reporting	System	PowerUp	MODBUS
Mode	RTU		?							
Address	1		?							
Data bits	8		?							
Stop bits	1		?							
Parity	NONE		?							
Termination Char ASCII code	10		?							
Inter-char timeout (ms)	1000		?							

Mode:	RTU or ASCII
Address:	1 to 247
Data Bits:	8 for Modbus RTU, 7 for Modbus ASCII
Stop Bits:	2 for No Parity, 1 for Even/Odd Parity
Parity:	NONE, ODD, or EVEN
Termination Char ASCII code:	10, (0-255)
Inter Char Timeout (mS):	1000 (500 to 10000)

# MaxiMet<sup>®</sup> Marine

## GMX560 Compact Weather Station

### Heating

The heating tab can be used to change the Heater Control Settings used by Maximet.

#### Heater Mode

This setting selects the way the heater will work. The options are

- Off – this mode disables the heater until the heater setting is changed
- Normal – this mode switches the heater on based upon the ambient temperature as configured by the user.

#### Heating ON/OFF temperature Limits

- The heating on temperature limit should be set to the temperature at which the heater will switch on.
- The heating off temperature limit should be set to the temperature at which the heater will switch off.

MetSet Configuration Software v2.17-01

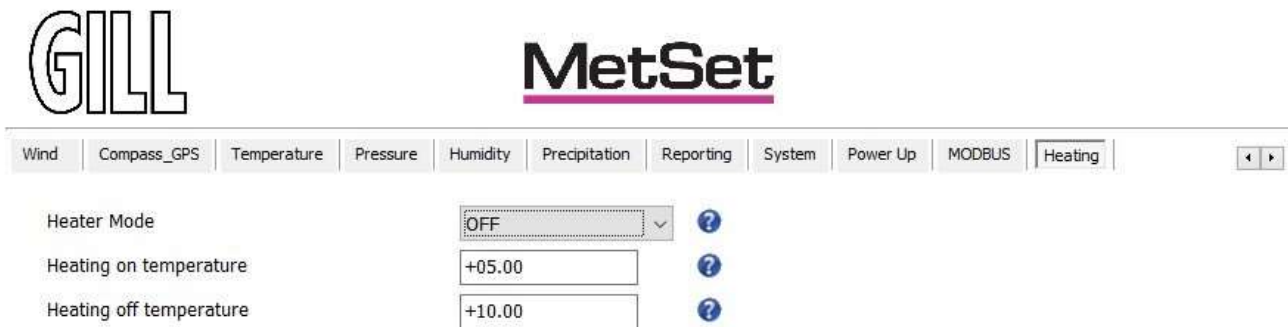

The screenshot shows the MetSet Configuration Software interface. At the top left is the 'GILL' logo, and at the top center is the 'MetSet' logo. Below the logos is a navigation bar with tabs for Wind, Compass\_GPS, Temperature, Pressure, Humidity, Precipitation, Reporting, System, Power Up, MODBUS, and Heating. The Heating tab is selected. Below the navigation bar, there are three settings: 'Heater Mode' is set to 'OFF' in a dropdown menu; 'Heating on temperature' is set to '+05.00' in a text input field; and 'Heating off temperature' is set to '+10.00' in a text input field. Each setting has a blue question mark icon to its right.



**WARNING: HOT SURFACE**

When heating is activated, the heated ultrasonic transducers will get very hot and should not be touched.

## GMX560 Compact Weather Station

### Polled Mode

#### Configuration for Polled Mode (MaxiMet Set for Power Mode 0)

To configure a MaxiMet Marine unit for polled mode:

1. Connect a default-set MaxiMet Marine to a PC as described in Section 5.
2. Open MetSet as described on Appendix D.
3. Click on the Edit Comms page:-
  - a. Set Protocol for required poll mode interface e.g. RS485.
  - b. Set Message Mode to Poll.
4. Click on Save Settings to Device on the Online Mode Menu.
5. Shut down the MaxiMet unit.
6. Change the hardware connections for the required poll mode interface.

#### Data Retrieval in Polled Mode (MaxiMet Marine Set for Power Mode 0)

The measurement rate shall always be 1Hz (i.e. regardless of the selected output rate or polling rate).

The configured measurement string shall be output in response to a measurement request ("`<network node address>`") from the user.

E.g. Q (where Q is the default MaxiMet Marine identifier, range A-Z).

When the user issues a poll measurement request, the last computed set of 1 Hz measurement shall be output.

Response time to a poll shall be less than 570 milliseconds but note that parameters that require GPS may not be readily available until satellite fix has been achieved.

# MaxiMet<sup>®</sup> Marine

## GMX560 Compact Weather Station

### Appendix E - Configuring MaxiMet Marine for Modbus



Please note that Pitch and Roll output parameters are currently unavailable when using Modbus.

#### MaxiMet Marine Supported Modbus Specification

Modbus RTU or ASCII  
Baud Rate 9600 or 19200 Baud  
COMMS RS232 point to point only, RS485 2 wire networkable

#### Modbus Parameters

Parameter	Modbus ASCII		Modbus RTU	
Character	ASCII 0 to 9 and A to F (Hex)		Binary 0 to 255	
Error Check	Longitudinal Redundancy Check (LRC)		Cyclic Redundancy Check (CRC)	
Frame Start	Character ':' (3A Hex)		3.5 Characters Silence	
Frame End	Characters CR/LF (0D/0A Hex)		3.5 Characters Silence	
Gaps in Message	1 Second		1.5 Times Character Length	
Start Bit	1		1	
Data Bits	7		8	
Parity	Even/Odd	None	Even/Odd	None
Stop Bits	1	2	1	2

- Read Holding Registers function code is 0x03
- Diagnostics 0x08
- Get Comm event counter 0x0B
- Report slave/server ID 0x11

Requires: MaxiMet  
MetSet Software

1. Connect a MaxiMet to a PC COM port (default communication is RS232).
2. Open Gill MetSet Software.
3. Click on Connect and Read to reach the editing pages as shown below.

# MaxiMet® Marine

## GMX560 Compact Weather Station

### Configuration

1. Select the Modbus page  
Mode: Choose between RTU and ASCII, in this case RTU  
Address: Choose a MaxiMet address number between 1 to 247  
Data Bits: Choose 7 for Modbus ASCII and 8 for Modbus RTU  
Stop Bits: Choose 1 for Even/Odd Parity or 2 for No Parity (None)  
Parity: Choose Even/Odd or None  
Termination Char ASCII code: Choose between 0-255  
Inter Char Timeout (ms): Choose 500ms - 10000ms

Comms	ASCII_Setup	Wind	Temperature	Pressure	Humidity
	Mode				
	Address				
	Data bits				
	Stop bits				
	Parity				
	Termination Char ASCII code				
	Inter-char timeout (ms)				

2. Select the COMMS Page  
Protocol: Default is Gill Select Modbus  
Interface: Default is RS232 Select RS232 or RS4852W  
RS232 will only allow a single point to point non multi drop network connection. RS485 2 wire will allow networking with up to 32 connected devices.  
Baud Rate: Default is 19200 Select required Baud Rate (9600 or 19200 supported)  
Node ID: Default is Q Not used for Modbus  
Output Rate: Default is 1Hz Set update rate for MaxiMet Marine Data  
Message Mode: Default is CONT Ensure that the setting is CONT mode; Message Mode POLL is not applicable for Modbus use.

Comms	ASCII_Setup	Wind	Temperature	Pressure	Humidity



# MaxiMet® Marine

## GMX560 Compact Weather Station

- When the required settings have been selected click on Write Settings.

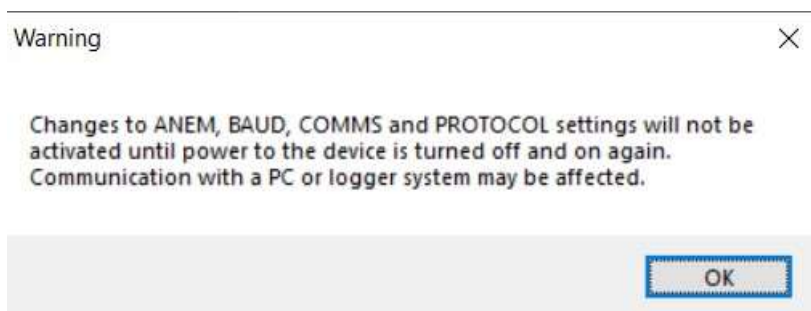

- Click on Yes and then OK.

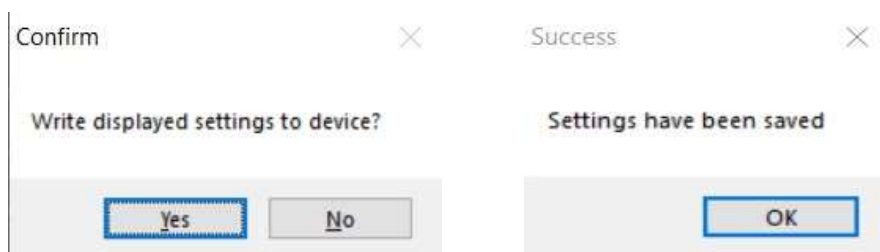

- Power down the MaxiMet and apply power back to the MaxiMet to complete setting changes.



Now that the unit is in Modbus mode if any further changes need to be made use the SAFE MODE connection and method to re-establish communication with MetSet (See Appendix H).

### Taking Measurements in Modbus Mode

- To determine Modbus register numbers applicable to a MaxiMet parameter, start out with setting up the MaxiMet in ASCII mode and determining which parameters are to be output, and the exact order that they are to be output before setting to Modbus Comms.
- Refer to the Modbus output parameter table below to determine how many registers each chosen parameter will take up.
- Fill up the register table, starting at 40001, with the required output parameters in the order in which they will be output.



After powering up the MaxiMet, wait 10 seconds before requesting any measurements.

# MaxiMet<sup>®</sup> Marine

## GMX560 Compact Weather Station

### Summary of Modbus output parameters

Output Parameter	Type	No. of Registers
NODE	4 Bit Character String	2
SPEED	32 Bit Floating Point Value	2
CORRECTED SPEED	32 Bit Floating Point Value	2
GUST SPEED	32 Bit Floating Point Value	2
CORRECTED GUST SPEED	32 Bit Floating Point Value	2
AVERAGE SPEED	32 Bit Floating Point Value	2
AVERAGE CORRECTED SPEED	32 Bit Floating Point Value	2
DIRECTION	32 Bit Floating Point Value	2
CORRECTED DIRECTION	32 Bit Floating Point Value	2
GUST DIRECTION	32 Bit Floating Point Value	2
CORRECTED GUST DIRECTION	32 Bit Floating Point Value	2
AVERAGE DIRECTION	32 Bit Floating Point Value	2
AVERAGE CORRECTED DIRECTION	32 Bit Floating Point Value	2
PRESSURE	32 Bit Floating Point Value	2
PRESSURE AT SEA LEVEL	32 Bit Floating Point Value	2
PRESSURE AT STATION	32 Bit Floating Point Value	2
RELATIVE HUMIDITY	32 Bit Floating Point Value	2
ABSOLUTE HUMIDITY	32 Bit Floating Point Value	2
TEMPERATURE	32 Bit Floating Point Value	2
DEWPOINT	32 Bit Floating Point Value	2
WIND CHILL	32 Bit Floating Point Value	2
HEAT INDEX	32 Bit Floating Point Value	2
AIR DENSITY	32 Bit Floating Point Value	2
WET BULB TEMPERATURE	32 Bit Floating Point Value	2
X TILT	32 Bit Floating Point Value	2
Y TILT	32 Bit Floating Point Value	2
Z ORIENTATION	32 Bit Floating Point Value	2
COMPASS HEADING	32 Bit Floating Point Value	2
GPS HEADING	32 Bit Floating Point Value	2
GPS SPEED OVER GROUND	32 Bit Floating Point Value	2
GPS LOCATION (Longitude)	32 Bit Floating Point Value	2
GPS LOCATION (Latitude)	32 Bit Floating Point Value	2
GPS LOCATION (Height)	32 Bit Floating Point Value	2
GPS STATUS (Fix/no. of satellites)	4 Bit Character String	2
TIME (Date)	16 Byte Character String	8
TIME (Time)	16 Byte Character String	8
SUPPLY VOLTAGE	32 Bit Floating Point Value	2
HEATSTAT	32 Bit Unsigned Interer (UNIT)	2
STATUS	32 Bit Unsigned Integer (UINT)	2
WINDSTAT	32 Bit Unsigned Integer (UINT)	2
USERINFO	16 Bit Character String	8

## GMX560 Compact Weather Station

- All registers are 16-bit. The first byte is high order and the second is low.
- Each measurement is comprised of two 16bit registers.
  - For each register, the order of the two data bytes comprising the 16-bit register's value shall be: High Byte/Low Byte.
  - For each 32-bit data type (whether floating point or integer), the order of the first pair of bytes and last pair of bytes shall be: High Word/Low Word.
- Registers start at address 40001.
- Holding registers are available in the order of the MaxiMet Marine data string (which can be established by the REPORT command in non-Modbus Gill ASCII Mode).
- If measurements cannot be computed (i.e. a blank field in Gill mode output string/conditions for reporting Wind Chill/ Heat Index are not being met), their Holding Register contents shall be set to the Maximum Positive value (0x7FFFFFFF for 32-bit format data (both floating point and integer), and as 0x7FFF for 16-bit format data).

### Modbus Default Setting Register Table:

Register Type	Register Numbers	Value Type
4ch string	40001-02	Node
32bit float	40003-04	Direction
32bit float	40005-06	Speed
32bit float	40007-08	Corrected Direction
32bit float	40009-10	Pressure
32bit float	40011-12	Relative Humidity
32bit float	40013-14	Temperature
32bit float	40015-16	Dew point
16ch string	40017-24	Date
16ch string	40025-32	Time
32bit float	40033-34	Supply Voltage
32bit UINT	40035-36	Status

# MaxiMet<sup>®</sup> Marine

## GMX560 Compact Weather Station

Simply Modbus program reading example, default output Modbus data as follows:

register #	bytes	results	notes
40001	0000 0051	Q	NODE
40003	4324 0000	41.0000000	DIR
40005	3D28 D70A	0.04000000	SPEED
40007	428C 0000	70.0000000	CDIR
40009	3E86 1EB8	0.25999999	CSPEED
40011	4480 0333	1024.09998	PRESS
40013	421C 0000	39.0000000	RH
40015	41C3 1EB8	24.38999994	TEMP
40017	4118 A3D7	9.53999996	DEW
40019	0000 0000	2023-05-18	DATE
40027	0000 0000	14:25:45.6	TIME
40035	40A3 3333	5.09999990	VOLT
40037	0000 0004	-4	STATUS

Simply Modbus program reading example, GPS default output Modbus data as follows:



Register data 40001 to 40006 will be as per the above example.

register #	bytes	results	notes
40003	4382 0000	260.000000	DIR
40005	3CA3 D70A	0.02000000	SPEED
40007	4318 0000	152.000000	CDIR
40009	3CA3 D70A	0.02000000	CSPEED
40011	4480 266E	1025.19995	PRESS
40013	4238 0000	46.0000000	RH
40015	41B8 0F5C	23.06999997	TEMP
40017	412F AE15	10.9800005	DEW
40019	424B F6C0	50.9909668	GPS LONGITUDE
40021	BFB8 4E22	-1.48653817	GPS LATITUDE
40023	4216 C0CD	37.7000008	GPS HEIGHT
40025	0000 0000	2023-05-18	DATE
40033	0000 0000	11:47:36.6	TIME
40041	40A3 3333	5.09999990	VOLT
40043	0000 0004	4	STATUS

# MaxiMet<sup>®</sup> Marine

## GMX560 Compact Weather Station

### Appendix F - Configuring MaxiMet for NMEA 0183 Output

1. Connect a default set MaxiMet Marine to a PC as described in Section 5.
2. Open MetSet as described on Appendix D and click on the Reporting page.
3. Change the Report Format drop down menu from USERDEF to NMEA.
4. On the Comms page select the required Interface, generally RS422.
5. On the Comms page select the required Baud Rate, normally 4800 baud (or sometimes 9600 baud).
6. Click on Save Settings to Device.



Wind Speed & pressure units will reflect Gill ASCII output setting (default metres per second & hecto pascals respectively).

#### NMEA Output String

```
$WIMWW,049,R,000.03,N,A*03<CR><LF>.
```

Where:-

\$WIMWW	Wind Instrument Mean Wind direction and Velocity.
049	Wind Direction.
R	Relative Wind measurement, wind speed and/or direction information, reported with respect to the MaxiMet North marker.
000.03	Wind Speed.
N	Knots
A	Acceptable measurement (V is a void fail measurement).
03	Hex Checksum*

Immediately followed by:-

```
$WIMWW,049,T,,N,A*18<CR><LF>.
```

Where:-

\$WIMWW	Wind Instrument Mean Wind direction and Velocity.
049	Wind Direction.
T	True Wind measurement, wind speed and/or direction information, corrected by a compass and GPS (option) to give accurate data regardless of where north marker is aligned.
,	Wind Speed only available if a GPS option is fitted.
N	Knots
A	Acceptable measurement (V is a void fail measurement).
18	Hex Checksum*

Immediately followed by:-

\$WIHDM,+261.6,M,*38	HDM sentence transmitted when heading is magnetic.
\$WIHDT	HDT sentence transmitted when heading is true. A true heading is used when a declination has been entered.

# MaxiMet<sup>®</sup> Marine

## GMX560 Compact Weather Station

Immediately followed by:-

\$WIXDR,A,+02.9,D,PITCH,A,+00.7,D,ROLL\*07

Where: -

\$WIXDR Wind Instrument Transducer

A	Angle
+02.9	Pitch Reading
D	Degrees
PITCH	Name of Reading
A	Angle
+00.7	Roll Reading
D	Degrees
ROLL	Name of Reading
*07	Hex Checksum*

Immediately followed by:-

\$WIXDR,C,+023.9,C,TEMP,P,1.0243,B,PRESS,H,039,P,RH,\*01<CR><LF>.

Where: -

\$WIXDR Wind Instrument Transducer

C	Type of Sensor (Temperature)
+023.9	Temperature Reading
C	Temperature Reading in Degrees Centigrade
TEMP	Name of Temperature Sensor
P	Type of Sensor (Pressure)
1.0243	Pressure Reading in Bars.
B	Pressure Units of Measure (Bars)
PRESS	Name of Pressure Sensor
H	Type of Sensor (Humidity)
039	Humidity Reading in Percent
P	Humidity Units of Measure (Percent)
RH	Name of Relative Humidity Sensor
*01	Hex Checksum*

Followed by GPS data if option available.

\$GPGGA,161229.487,3723.2475,N,12158.3416,W,1,07,1.0,9.0,M, , , ,0000\*18<CR><LF>.

Where

\$GPGGA NMEA GPS Protocol Header

161229.487	UTC Time, hhmmss.sss
3723.2475	Latitude ddmm.mmmm
N	North/South Indicator
12158.3416	Longitude ddmm.mmmm
W	East/West indicator
1	Position Fix Indicator (See below)

# MaxiMet<sup>®</sup> Marine

## GMX560 Compact Weather Station

07	Satellites being used (Range 0-12)
1.0	Horizontal Dilution of Precision
9.0	Mean Sea Level (NSL) Altitude in Metres
M	MSL Units, Metres
, , , ,	Geoid Separation and Units in Metres
0000	Differential GPS Reference Station ID.
*18	Hex Checksum*

<CR> is a Carriage return character (ASCII hex value d)

<LF> is a Line Feed Character (ASCII hex value a)

### Immediately followed by:

\$PGILT,A,+XX,D,+YY,D,+Z,TILT\*HH<CR><LF>

Where: \$P Start of sentence and proprietary sentence identifier

GIL Gill Instruments recognised NMEA manufacturer mnemonic

T Indicates TILT information

A Type of Sensor (Angular Displacement)

+XX X-Tilt indicates unit is tipping towards east "XX" degrees

Or -XX X Tilt indicates unit is tipping towards west "XX" degrees

D Units (Degrees)

+YY Y-Tilt indicates unit is tipping towards north "YY" degrees

Or -YY Y-Tilt indicates unit is tipping towards south "YY" degrees

D Units (Degrees)

+Z Z-Orientation "+1" shall be reported if the unit is installed upright, or "-1" if facing downwards

TILT Name of the Sensor

\*HH Hex Checksum\*

<CR><LF> End of message termination

Example GMX500 NMEA Data String.

\$WIMWV,275,R,000.01,N,A\*0C

\$WIMWV,180,T,000.11,N,A\*02

\$WIXDR,C,+023.1,C,TEMP,P,0.9989,B,PRESS,H,040,P,RH\*25

\$GPGGA,113342.000,5045.7837,N,00132.4127,W,1,06,1.3,-10.2,M,47.8,M,,0000\*56 (GPS option unit)

\$PGILT,A,+00,D,+01,D,+1,TILT\*35

Repeated every second (1Hz output).

\*Checksum, the 2 digit Hex Checksum sum figure is calculated from the Exclusive OR of the bytes between (and not including) the \$ and \* characters.

# MaxiMet<sup>®</sup> Marine

## GMX560 Compact Weather Station

### Appendix G - Configuring MaxiMet for SDI-12

To configure a MaxiMet unit for SDI-12:

1. Connect a default-set MaxiMet to a PC as described in section 5.
2. Open MetSet as described on Appendix D.
3. Click on the Edit Comms page:-
  - a. Set Protocol for SDI-12.
  - b. Set Interface for SDI-12.No other settings changes are required.
4. Click on Save Settings to Device on the Online Mode Menu.
5. Shut down the MaxiMet unit.
6. Change the hardware connections for SDI-12 (see section 5).
7. Power up the MaxiMet unit (SDI-12 supply voltage 9.6V to 16V DC). Allow 10 seconds for the unit to start up before sending an SDI-12 command.



When Protocol is set for SDI-12 mode it automatically sets the MaxiMet Baud Rate to 1200 baud irrespective of its Baud setting.

Only parameters mentioned below are available in SDI-12 Protocol mode irrespective of the Reporting page setting.

#### SDI-12 Output Parameters

Relative Wind Speed:	Metres per second (m/s)
Corrected Wind Speed:	Metres per second (m/s)
Average Relative Wind Speed	Metres per second (m/s)
Relative Gust Speed	Metres per second (m/s)
Relative Wind Direction:	Degrees (°)
Corrected Wind Direction:	Degrees (°)
Average Relative Wind Direction	Degrees (°)
Relative Gust Direction	Degrees (°)
Temperature:	Degrees Celsius (°C)
Relative Humidity:	Percent (%)
Dewpoint:	Degrees Celsius (°C)
Pressure:	Hectopascals (hPa)
Wind Chill:	Degrees Celsius (°C)
Heat Index:	Degrees Celsius (°C)
Air Density:	Kilograms per metre cubed (kgm <sup>-3</sup> )
Wet Bulb Temperature:	Degrees Celsius (°C)
X Tilt:	Positive or Negative Degrees (°)
Y Tilt:	Positive or Negative Degrees (°)
Z Orientation:	1 or 0
Height above sea level:	Metres (m)
Pitch	Positive or Negative Degrees (°)
Roll	Positive or Negative Degrees (°)
Latitude:	Degrees (positive values are N, negative are S)
Longitude:	Degrees (positive values are E, negative are W)
Date:	Years-Months-Days
Time:	Hours:Minutes:Seconds (h:min:s)
Status	4 Digit Sensor Status Code (e.g. 0000 for a no-fault condition)



## GMX560 Compact Weather Station

### SDI-12 Commands



For each of the available aMx! commands and the aC! command there exists an equivalent aMCx! and aCC! command that provides a 3 character CRC on the associated send data command (aD0!, aD1! ...) immediately before the <CR><LF> characters. The CRC is calculated as per the SDI-12 Standard.



Unavailable measurements shall be "padded", e.g.: +999.99

- ?! Returns unit address (default is 0)
- a Current unit address letter (factory default is 0, range is 0 to 9)
- b New address letter, range 0 to 9
- aAb! Change unit address from a to b (see above)
- aM! Address, Relative Wind Direction, Relative Wind Speed, Corrected Wind Direction, Corrected Wind Speed (GPS option units only), Status
- aM1! Address, Temperature, Relative Humidity, Dewpoint, Pressure, Status, Wind Chill, Heat Index, Air Density, Wet Bulb Temperature
- aM2! Address, Compass heading or heading, pitch, roll, status
- aM4! Address, X Tilt, Y Tilt, Z Orientation, Status
- aM5! Address, signed Latitude integer part, signed Latitude fractional part, signed Longitude integer part, signed Longitude fractional part, Height Above Mean Sea Level, Status
- aM6! Address, Year, Month, Day, Hour, Minute, Second, Status
- aM8! Address, Relative Average Wind Direction, Relative Average Wind Speed, Relative Gust Wind Direction, Relative Gust Wind Speed, Units 1=ms, 2=kph, 3=mph, 4=knots, 5=fpm, Status
- aM9! Address, relative Average Wind Direction, Relative Average Wind Speed, Relative Gust Wind Direction, Relative Gust Wind Speed, Status
- aD0! Request a line of the above data
- aC! Concurrent measurement grouped into primary measurements, time/location, average/gust and derived
- aMC2! Address, compass heading or heading, pitch, roll, status, crc
- aD0! Address, relative direction, relative wind speed, corrected direction, corrected wind speed, temp, relative humidity, pressure
- aD1! Address, x-tilt, y-tilt, z orientation, an1, an2, dig1, volt
- aD2! Address, date year, date month, date day, time hour, time minute, time second, gps latitude integer, gps latitude fraction, gps longitude integer, gps longitude fraction, gps height above sea level
- aD3! Address, wmo average direction, wmo average wind speed, wmo relative gust direction, wmo relative gust wind speed, wmo average wind speed units, wmo relative gust wind speed units, Units 1=ms, 2=kph, 3=mph, 4=knots, 5=fpm
- aD4! Address, wind chill, heat index, air density, wet bulb temperature, dew point
- aD5! Address, sunrise, solar noon, sunset, sun position azimuth, sun position elevation, twilight civil, twilight nautical, twilight astronomical, status
- aXU1! set measurement units for aM8! to m/s
- aXU2! set measurement units for aM8! to kph
- aXU3! set measurement units for aM8! to mph
- aXU4! set measurement units for aM8! to knots
- aXU5! set measurement units for aM8! to feet per minute
- aXA1mm! set long term averaging period (mm=minutes, 01-60).
- aXG1ss! set period for gust speed and direction rolling average (ss=01-10 seconds)
- aXG2mm! set period of gust would be reported (mm = 01-60), where mm is the number of short term average periods.

# MaxiMet® Marine

## GMX560 Compact Weather Station

Command	Description	Response	Example
?!	Unit address	a<CR><LF>	0<CR><LF>
aAb!	Change the unit address  a = 0, the default b = the new address	b<CR><LF>	1<CR><LF>
a!	Unit identification	013GillInst <serial number><CR><LF>	013GillInst 00014490002<CR><LF>
aM!	Address, Relative Wind Direction, Relative Wind Speed, Corrected Wind Direction, Corrected Wind Speed (GPS option unit only), Status	atttn<CR><LF>  a is unit identifier ttt is time in seconds n is number of data values  Measurement command to retrieve a reading of the maximum time the MaxiMet will take to complete a measurement, have data ready and the number of data values.	00035<CR><LF>  0 is unit identifier 003 is 3s measurement 5 is the number of data readings (Direction, Speed, Corrected Direction and Corrected Speed)
aD0!	Retrieve a line of the above data.	<address><relative wind direction><relative wind speed><corrected wind direction><corrected wind speed><status><CR><LF>	0+220+000.01+218+999.99+0000<CR><LF>
aM1!	Address, Temperature, Relative Humidity, Dewpoint, Pressure, Status, Wind Chill, Heat Index, Air Density, Wet Bulb Temperature	atttn<CR><LF>	00029<CR><LF>
aD0!	Retrieve a line of the above data.	<address><temperature><relative humidity><dewpoint><pressure><status> <wind chill><CR><LF>	0+021.8+035+005.7+1006.2+000+999<CR><LF>
aD1!	Retrieve final part of the above data	<address><heat index><air density><wet bulb temperature><CR><LF>	0+999+1.2+013.0<CR><LF>
aM2!	Address, Compass heading or heading, pitch, roll, status	atttn<CR><LF>	00034<CR><LF>
aD0!	Retrieve a line of the above data.	<address><dir><mag><status><CR><LF>	0+120.0+00.9+01.1+0002<CR><LF>

# MaxiMet® Marine

## GMX560 Compact Weather Station

aM3!	Address, Precipitation Intensity, Total Precipitation, Status	attn<CR><LF>	00033<CR><LF>
aD0!	Retrieve a line of the above data.	<address><precipitation intensity><total precipitation><status><CR><LF>	0+999.999+0999.999+0002<CR><LF>
aM4!	Address, Solar Radiation, Sunshine Hours, X Tilt, Y Tilt, Z Orientation, Status	attn<CR><LF>	00026<CR><LF>
aD0!	Retrieve a line of the above data.	<address><solar radiation><sunshine hours><x-tilt><y-tilt><z-orientation><status><CR><LF>	0+9999+99.99+01+00-1+0000<CR><LF>
aM5!	Address, signed Latitude integer part, signed Latitude fractional part, signed Longitude integer part, signed Longitude fractional part, Height Above Mean Sea Level, Status	attn<CR><LF>	00026<CR><LF>
aD0!	Retrieve a line of the above data.	<address><signed latitude integer part><signed latitude fractional part><signed longitude integer part><signed longitude fractional part><height above mean sea level><status> <CR><LF>	0+50+763052-001-539920+00000.90+0000<CR><LF>
aM6!	Address, Year, Month, Day, Hour, Minute, Second, Status	attn<CR><LF>	00027<CR><LF>
aD0!	Retrieve a line of the above data.	<address><year><month><day><hour><minute><second><status><CR><LF>	0+2015+06+15+14+07+52+0000<CR><LF>
aM7!	Address, Sunrise Time, Solar Noon Time, Sunset Time, Position of the Sun (Azimuth), Position of the Sun (Elevation), Twilight (Civil), Twilight (Nautical), Twilight (Astronomical), Status	attn<CR><LF>	00039<CR><LF>

# MaxiMet® Marine

## GMX560 Compact Weather Station

aD0!	Retrieve part of the above data.	<address><sunrise time><solar noon time><sunset time><position of the sun (azimuth)><position of the sun (elevation)><twilight (civil)><twilight (nautical)><CR><LF>	0+0515+1152+1829+115+27+1908+1950<CR><LF>
aD1!	Retrieve final part of the above data	<address><twilight (astronomical)><status><CR><LF>	0+2034+0000<CR><LF>
aM8!	Address, Relative Average Wind Direction, Relative Average Wind Speed, Relative Gust Wind Direction, Relative Gust Wind Speed, Units 1=ms, 2=kph, 3=mph, 4=knots, 5=fpm, Status	Atttn<CR><LF>	00036<CR><LF>
aD0!	Retrieve a line of the above data.	<address><relative Average Wind Direction (0-359)><Relative Average Wind Speed (units as set by aXUn! command)><Relative Gust Wind Direction (0-359)><Relative Gust Wind Speed (units as set by aXUn! command)><Units 1=ms, 2=kph, 3=mph, 4=knots, 5=fpm><Status><CR><LF>	0+323+000.05+310+000.41+1+0000<CR><LF>
aM9!	Averaged wind measurement with units set as m/s	Atttn<CR><LF>	00035<CR><LF>
aD0!	Retrieve a line of the above data.	<address><relative Average Wind Direction (0-359)><Relative Average Wind Speed (m/s)><Relative Gust Wind Direction (0-359)><Relative Gust Wind Speed (m/s)><Status><CR><LF>	0+000+000.00+309+001.42+0000<CR><LF>
aC!	Concurrent measurements grouped into primary measurements, time/location, average/gust, and derived.	atttnn<CR><LF>	000350<CR><LF>

# MaxiMet® Marine

## GMX560 Compact Weather Station

aD0!	Retrieve a line of the above data. (primary measurements)	<address><relative direction><relative wind speed><corrected direction><corrected wind speed><temp><relative humidity><pressure><precipitation intensity><solar radiation><CR><LF>	0+286+000.03+296+000.08+022.2+055+1001.4+000.000+0002<CR><LF>
aD1!	Retrieve a line of the above data. (primary measurements)	<address><x-tilt><y-tilt><z orientation><an1><an2><dig1><volt><CR><LF>	0+00-01+1+9999.99+9999.99+9999.99+11.8<CR><LF>
aD2!	Retrieve a line of the above data. (time/location)	<address><date year><date month><date day><time hour><time minute><time second><gps latitude integer><gps latitude fraction><gps longitude integer><gps longitude fraction><gps height above sea level><CR><LF>	0+2020+01+30+13+19+37+50+763148-001-540111-0001.10<CR><LF>
aD3!	Retrieve a line of the above data. (average/gust)	<address><wmo average direction><wmo average wind speed><wmo relative gust direction><wmo relative gust wind speed><wmo average wind speed units><wmo relative gust wind speed units><Units 1=ms, 2=kph, 3=mph, 4=knots, 5=fpm><CR><LF>	0+323+000.05+310+000.41+1+0000<CR><LF>
aD4!	Retrieve a line of the above data. (derived)	<address><wind chill><heat index><air density><wet bulb temperature><dew point><precipitation total><solar hours><CR><LF>	0+999+999+1.2+016.3+012.7+0000.00+00.00<CR><LF>
aD5!	Retrieve a line of the above data. (derived)	<address><sunrise><solar noon><sunset><sun position azimuth><sun position elevation><twilight civil><twilight nautical><twilight astronomical><status><CR><LF>	0+0745+1218+1652+220+12+1727+1807+1846+0004<CR><LF>
aXU1!	set measurement units for aM8! to m/s	aUM/S<CR><LF>	0UM/S<CR><LF>
aXU2!	set measurement units for aM8! to kph	aUKPH<CR><LF>	0UKPH<CR><LF>

# MaxiMet® Marine

## GMX560 Compact Weather Station

aXU3!	set measurement units for aM8! to mph	aUMPH<CR><LF>	0UMPH<CR><LF>
aXU4!	set measurement units for aM8! to knots	aUKTS<CR><LF>	0UKTS<CR><LF>
aXU5!	set measurement units for aM8! to feet per minute	aUFPM<CR><LF>	0UFPM<CR><LF>
aXA1mm!	set long term averaging period (mm=minutes, 01-60).	aA1<CR><LF>	0A1<CR><LF>
aXG1ss!	set period for gust speed and direction rolling average (ss=01-10 seconds)	aG1<CR><LF>	0G1<CR><LF>
aXG2mm!	set period of gust would be reported (mm = 01-60), where mm is the number of short term average periods.	aG2<CR><LF>	0G2<CR><LF>

### Appendix H - Safe Mode

#### Summary

The MaxiMet Safe Mode provides a means of recovering communication with the MaxiMet Marine whatever configuration setting may have been made. For instance, if the unit has been set for SDI-12 or Modbus operation Safe Mode can be used to change the communication option back to RS232 or RS422.

#### Safe Mode Method 1

##### Connection

1. Connect the MaxiMet Marine for RS232 communication as detailed in section 5.
2. Open Gill MetSet Software (see Appendix D)
3. Click on Connect and Read. MetSet will scan COM port settings for a connected MaxiMet Marine but as the COMMS protocol is not matched will be unable initially to find the MaxiMet Marine.
4. Now click on the Safe Mode button.

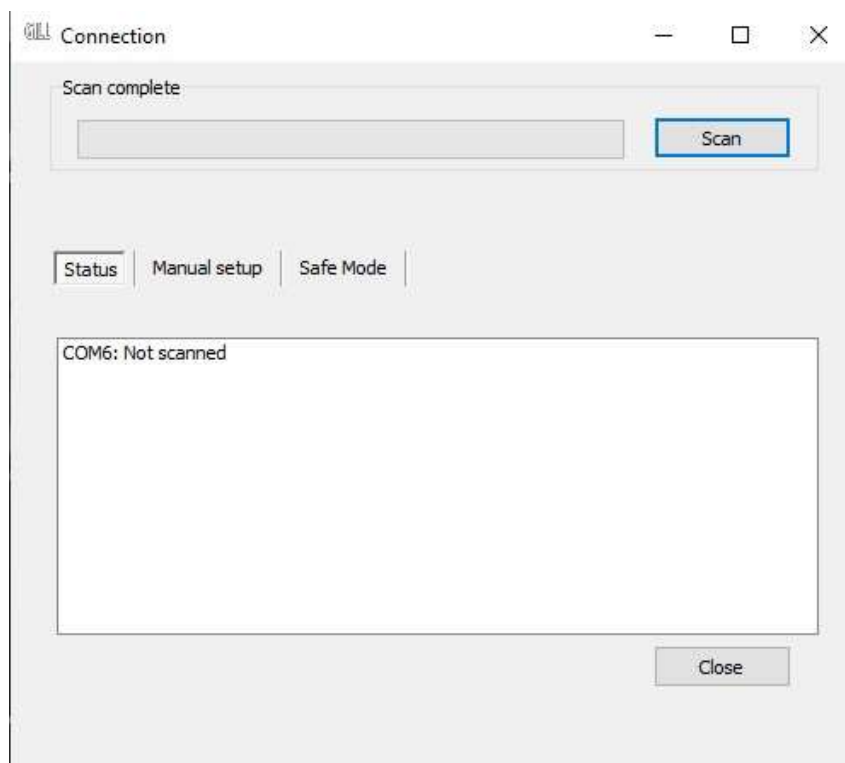

# MaxiMet<sup>®</sup> Marine

## GMX560 Compact Weather Station

5. Ensure the MaxiMet Marine is wired for RS232 operation and power and click on Next.

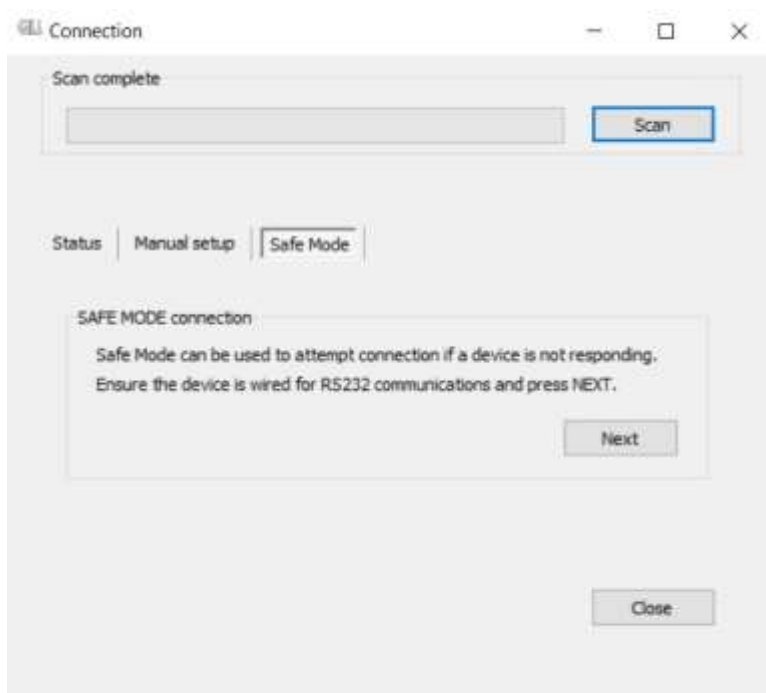

6. Enter the MaxiMet COM Port connection number.

 Using dongle check box is only applicable when using a MetConnect device.

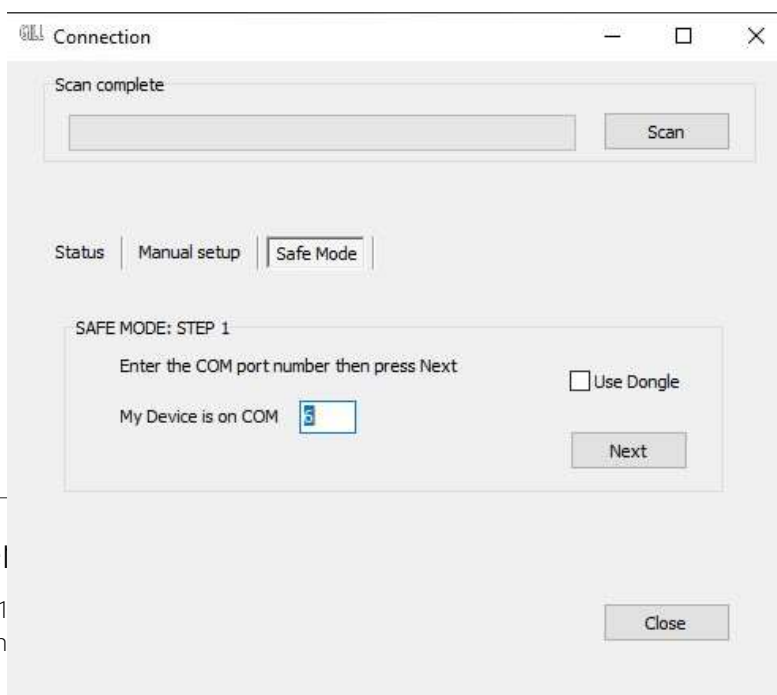



# MaxiMet<sup>®</sup> Marine

## GMX560 Compact Weather Station

7. Ensure power is now disconnected from the MaxiMet Marine.

 If using the Gill Instruments RS232 to USB configuration cable then unplug the 8-way connector from the base of the MaxiMet Marine.

8. Now click on Next.

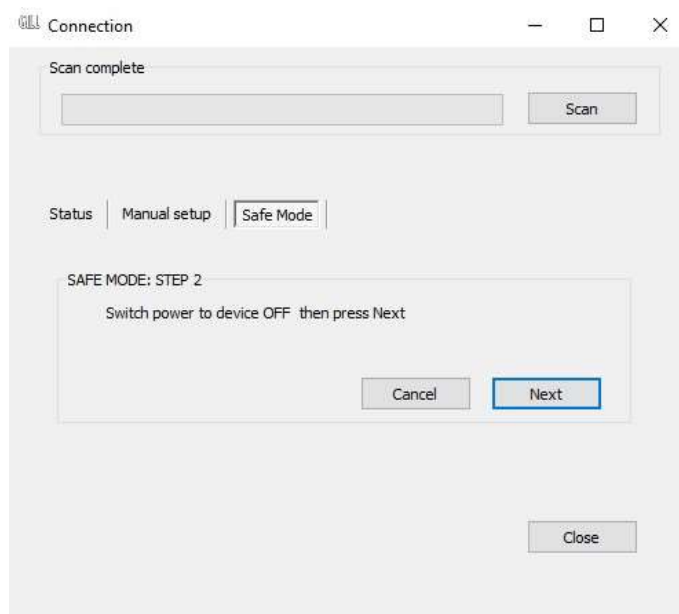

9. Re-connect power to the MaxiMet Marine.

 If using the Gill Instruments RS232 to USB configuration cable, then plug in the 8-way connector to the base of the MaxiMet Marine.

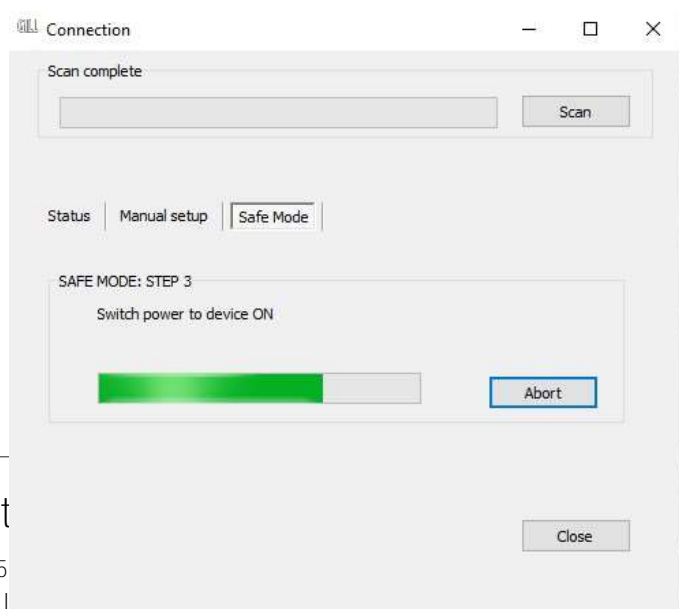

# MaxiMet<sup>®</sup> Marine

## GMX560 Compact Weather Station

---

10. Device will now connect and display a Summary of Device settings.

# MaxiMet<sup>®</sup> Marine

## GMX560 Compact Weather Station

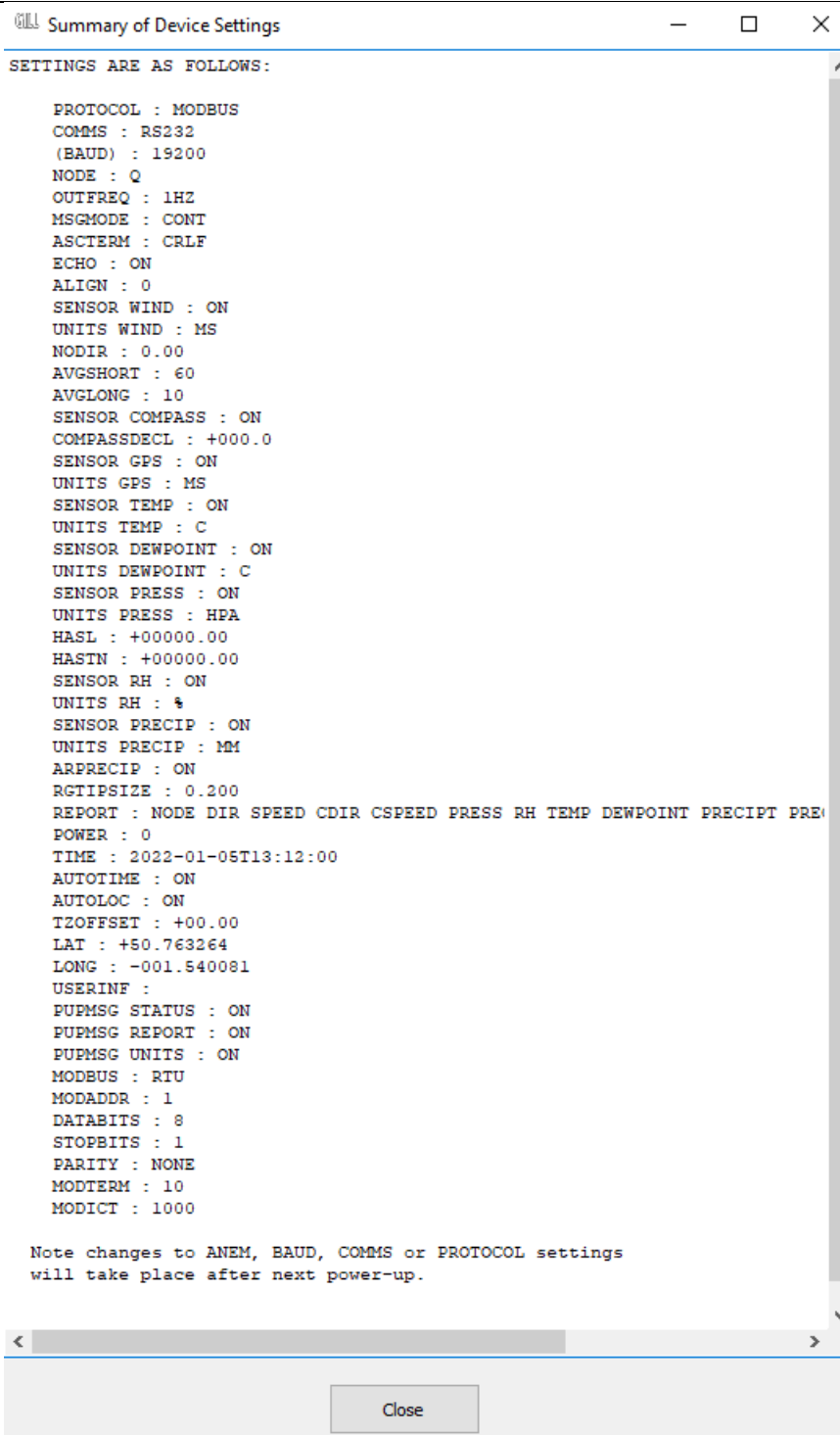

```
Gill Summary of Device Settings
SETTINGS ARE AS FOLLOWS:

PROTOCOL : MODBUS
COMMS : RS232
(BAUD) : 19200
NODE : Q
OUTFREQ : 1HZ
MSGMODE : CONT
ASCTERM : CRLF
ECHO : ON
ALIGN : 0
SENSOR WIND : ON
UNITS WIND : MS
NODIR : 0.00
AVGSHORT : 60
AVGLONG : 10
SENSOR COMPASS : ON
COMPASSDECL : +000.0
SENSOR GPS : ON
UNITS GPS : MS
SENSOR TEMP : ON
UNITS TEMP : C
SENSOR DEWPOINT : ON
UNITS DEWPOINT : C
SENSOR PRESS : ON
UNITS PRESS : HPA
HASL : +00000.00
HASTN : +00000.00
SENSOR RH : ON
UNITS RH : %
SENSOR PRECIP : ON
UNITS PRECIP : MM
ARPRECIP : ON
RGTIPSIZE : 0.200
REPORT : NODE DIR SPEED CDIR CSPEED PRESS RH TEMP DEWPOINT PRECIP PRE
POWER : 0
TIME : 2022-01-05T13:12:00
AUTOTIME : ON
AUTOLOC : ON
TZOFFSET : +00.00
LAT : +50.763264
LONG : -001.540081
USERINF :
PUPMSG STATUS : ON
PUPMSG REPORT : ON
PUPMSG UNITS : ON
MODBUS : RTU
MODADDR : 1
DATABITS : 8
STOPBITS : 1
PARITY : NONE
MODTERM : 10
MODICT : 1000

Note changes to ANEM, BAUD, COMMS or PROTOCOL settings
will take place after next power-up.
```

Close

11. MetSet now opens a Safe Mode 4800 baud connection from which all settings can now be read and changed.

# MaxiMet<sup>®</sup> Marine

## GMX560 Compact Weather Station

MetSet Configuration Software v2.10-01

**GILL** **MetSet**

Comms | ASCII\_Setup | Wind | Compass\_GPS | Temperature | Pressure | Humidity | Reporting | System | Power Up | MODBUS

Protocol: MODBUS ⚠  
Interface: RS232 ⚠  
Baud Rate: 19200 ⚠  
Node ID: Q ?  
Output rate: 1Hz ?  
Message Mode: CONT ?

Source: Defaults	S/N: 23160042	19200
MAXIMET GMX560-5D-00D5		19200 COM4
		S/W ver: 2669-2.00.24
		Protocol ver: 5

Write Settings | Read Settings  
Load Setup | Save Setup  
Backup Device Setup | Restore Device Setup  
Main Menu  
App. Manual

# MaxiMet<sup>®</sup> Marine

## GMX560 Compact Weather Station

### Safe Mode Method 2

#### Connection

1. Connect the MaxiMet Marine for RS232 communication as detailed in Section 5.



At this stage the MaxiMet Marine supply should be switched off.

If using the Gill Instruments RS232 to USB configuration cable then unplug the 8-way connector from the base of the MaxiMet Marine.

2. Open a terminal program e.g. Gill Wind Software (obtainable from <http://www.gillinstruments.com/main/software.html>) or equivalent terminal program e.g. Tera-Term, Putty etc.



If using Gill Wind Software the Tools features are not applicable.

3. Set the Serial Port to the required COM Port connection using the drop down menu and click on the OK button.
4. Set the Baud Rate to 4800 using the drop down menu. A blank Wind terminal screen will be opened.
5. Left click the mouse in the blank terminal screen.
6. Hold down the \* (asterisk) key on the keypad.
7. With the \* key still held down, apply power to the MaxiMet Marine  
If using the Gill Instruments RS232 to USB configuration cable then plug in the 8-way connector to the base of the MaxiMet Marine.  
This will result in placing the unit into SAFE MODE.
8. Press Enter to start a new line (Ignore illegal command line).

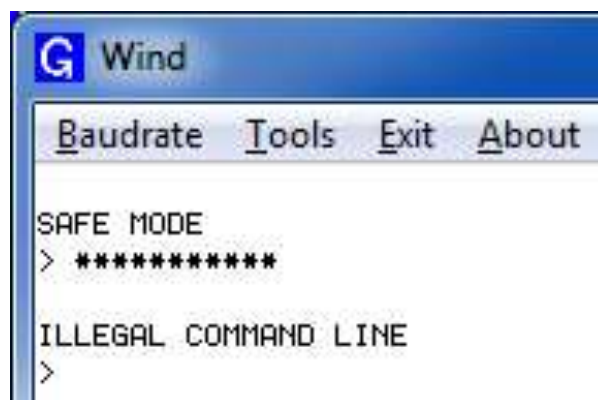

# MaxiMet<sup>®</sup> Marine

## GMX560 Compact Weather Station

To now change communication from, say, SDI-12 (or Modbus) or RS422 or RS485 to default RS232:

1. Type COMMS RS232 and press Enter.
2. Type Q and press Enter to exit SAFE MODE.
3. Data will now scroll on screen.

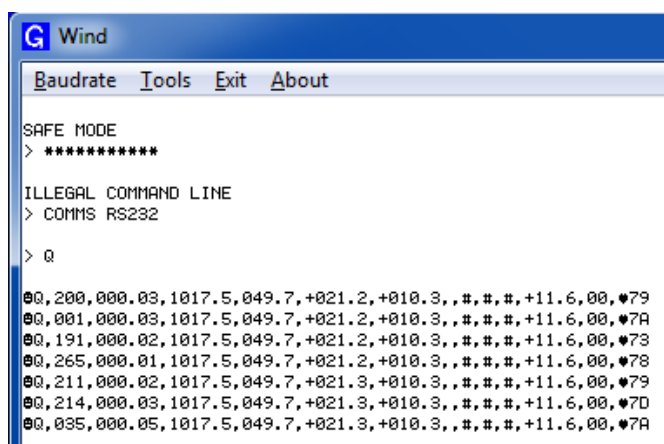

```
G Wind
-----
Baudrate  Tools  Exit  About

SAFE MODE
> *****

ILLEGAL COMMAND LINE
> COMMS RS232

> Q

00,200,000.03,1017.5,049.7,+021.2,+010.3,,#,#,+,11.6,00,79
00,001,000.03,1017.5,049.7,+021.2,+010.3,,#,#,+,11.6,00,7A
00,191,000.02,1017.5,049.7,+021.2,+010.3,,#,#,+,11.6,00,73
00,265,000.01,1017.5,049.7,+021.2,+010.3,,#,#,+,11.6,00,78
00,211,000.02,1017.5,049.7,+021.3,+010.3,,#,#,+,11.6,00,79
00,214,000.03,1017.5,049.7,+021.3,+010.3,,#,#,+,11.6,00,7D
00,035,000.05,1017.5,049.7,+021.3,+010.3,,#,#,+,11.6,00,7A
```

4. Close the 4800 baud rate Wind or terminal program.
5. Power down the MaxiMet Marine and re-apply power.
6. Open Gill MetSet software and read settings/change settings as required.

### Appendix I - Using a Terminal Program to run MaxiMet Marine Tilt function

For those MaxiMet units that have a Tilt function output it is possible to use a Check Tilt command that results in just X, Y, Z Tilt information (and compass output with wind output models) being output at 4Hz with additional decimal point accuracy, should this be required for installation set-up.

1. To enable this Tilt function it is necessary for the MaxiMet to be set and wired for RS232 or RS422 data two-way TX/RX communication and a suitable converter should be used to interface the MaxiMet to a PC running a terminal program.
2. Then connect the MaxiMet data output to a PC and open a terminal program e.g. Gill Wind software (note the Wind software Tools features are not applicable).
3. Select the required COM port connection e.g. COM 39.

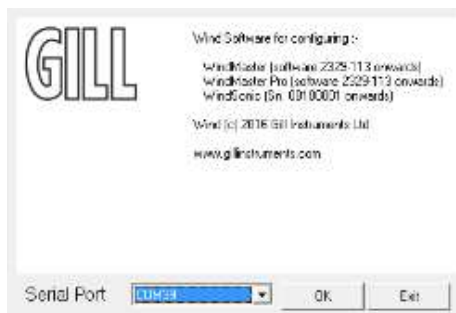

4. Select the baud rate from the drop down menu to match the MaxiMet setting (default 19200 baud).
5. MaxiMet data should scroll on screen.
6. Type \* (asterisk) to set the MaxiMet to SETUP MODE.
7. Type CHECKTILT and press the Enter key for 4Hz data output.
8. Adjust the MaxiMet positioning to achieve required tilt angles e.g. 0.0, 0.0,1 for ideal horizontal set up.
9. To return to MaxiMets pre-configured normal measurement output, power down and then power up the unit.



The Check Tilt function is not a memorised setting and as soon as power is reset the unit reverts to its pre-configured data string output setting.

# MaxiMet<sup>®</sup> Marine

## GMX560 Compact Weather Station

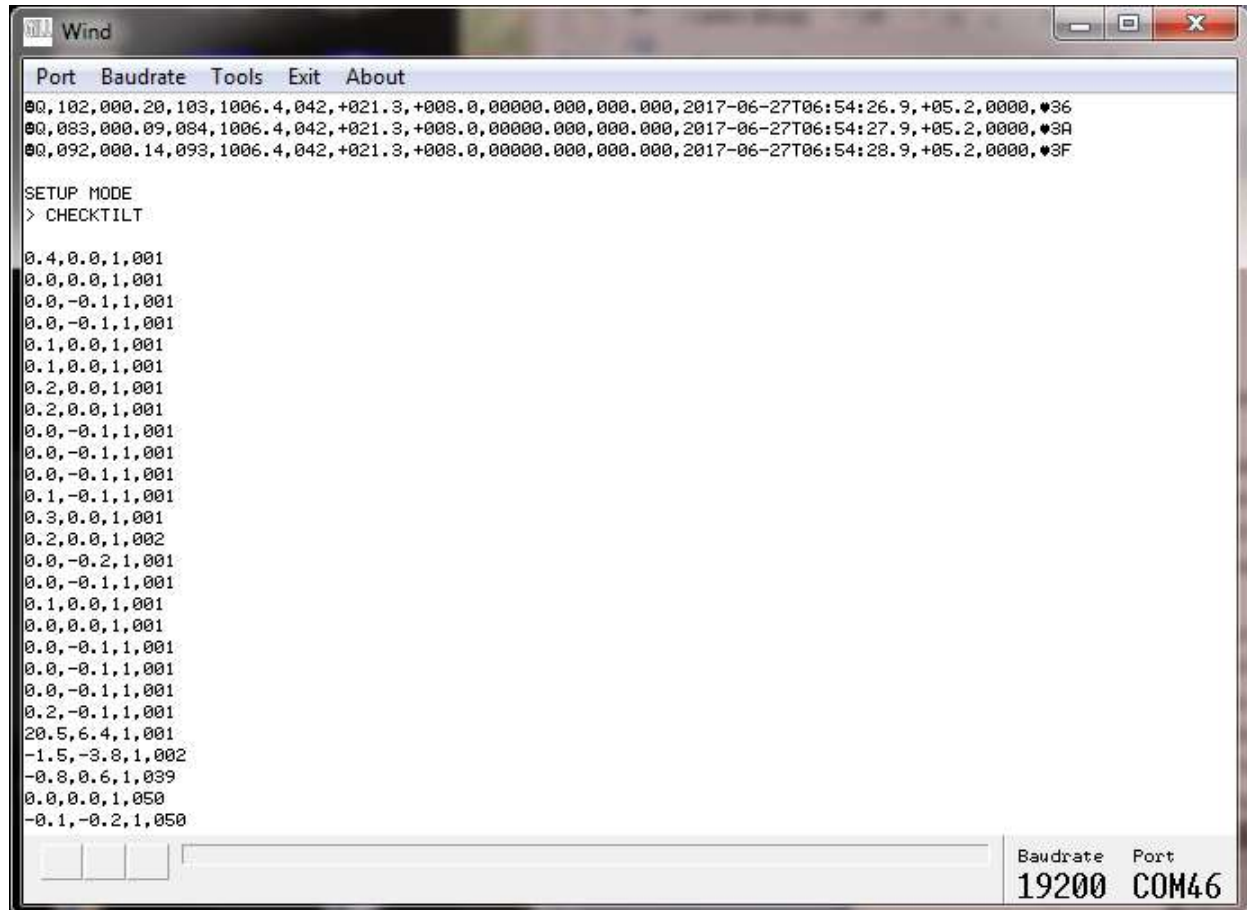



## GMX560 Compact Weather Station

### Appendix J - Using a Terminal Program to set MaxiMet Date and Time

As an alternative to using MetSet to set MaxiMet Marine time which might add a delay to time setting as MetSet saves settings (up to 60 seconds) then MaxiMet Marine TIME can be set manually with potentially more accuracy against a reference time as follows:

1. With the MaxiMet Marine set and wired for RS232 or RS422 data two-way TX/RX communication via a suitable converter, interface the MaxiMet Marine to a PC running a terminal program.
2. Open a terminal program e.g. Gill Wind software (note the Wind software Tools features are not applicable) or Tera Term or Putty etc.
3. Select the required COM port connection e.g. COM 39.

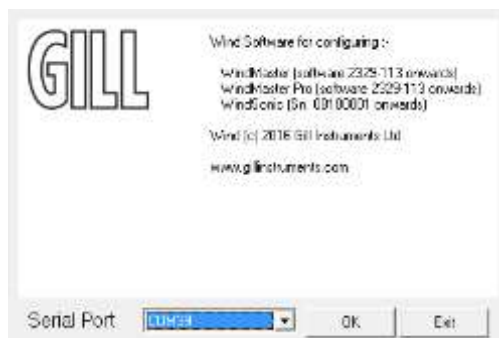

4. Select the baud rate to match the MaxiMet setting (default 19200 baud).
5. MaxiMet data should scroll on screen.

```
Q,027,000.23,311,1018.8,041,+025.4,+011.5,0002,2017-06-01T15:21:30.0,+05.2,0000,18  
Q,045,000.14,330,1018.8,041,+025.4,+011.5,0002,2017-06-01T15:21:31.0,+05.2,0000,1A
```

6. Type \* (asterisk) to set the MaxiMet to SETUP MODE.
7. Type TIME and Press the PC Enter key to show the current date and time (and format).  
TIME = 2017-06-01T15:25:00
8. To set a new TIME choose a convenient Time in the future say 5 minutes ahead.
9. Now Type in the new Date/Time in the following format:-  
TIME 2017-06-01T15:30:00  
(Year/Month/Day/Hours/Minutes/Seconds)
10. Using a reference accurate clock/watch showing current time compare this to the time set above.
11. When the two TIMES are matched press the PC Enter key to update the MaxiMet TIME to the reference time.
12. Type Q and press the Enter key to return the MaxiMet to Measurement mode with the updated TIME reading

# MaxiMet<sup>®</sup> Marine

## GMX560 Compact Weather Station

### Appendix K - Using Gill MetView Software to View the MaxiMet Data String

Install MetView software (V2.12-01 onwards) on to a PC from the Gill website at:

<http://gillinstruments.com/main/software.html>

MetView software allows you to view the MaxiMet data visually and has a simple data logging facility. Before you can use MetView, check that MaxiMet is correctly connected to a serial COM port or USB COM port on your PC.



MetView is compatible with RS232 and RS422 connected units set for ASCII only.

MetView will not read NMEA, SDI-12 or Modbus data strings.

Requires the use of MetView Software version 2.10-11 and higher to read MaxiMet Marine data.

#### Opening MetView

Click on the MetView button on your PC's desktop or choose Start > Programs > MetView > MetView.

The MetView Control Centre window is displayed as follows:



# MaxiMet® Marine

## GMX560 Compact Weather Station

### Connection is 'Receive-Only'

Use (tick) if the MaxiMet Marine connection to the PC has only transmit wires connected and a MetSet version of its current device settings is available to upload to MetView. Select 'Connection is 'Receive-Only'' tick box and click on the Scan button. Upload a MetSet generated device file from a PC location as directed.

### Connect to first device found

Selecting this box (default setting) means that if multiple MaxiMets are connected to the PC, MetView will connect to the MaxiMet Marine connected to the lowest-number COM port.

If the 'Connect to first device found' option is not selected, then all connected MaxiMet Marine COM port connections will be shown when the Scan button is selected.

### Scan Button

If MaxiMet Marine transmit and receive wires are connected to the PC then use the Scan button to connect to MetView.

### Scanning for Devices

To set up communications between MetView and a connected MaxiMet Marine:

1. Click on the Scan button to search the available COM ports for connected MaxiMet Marine units.

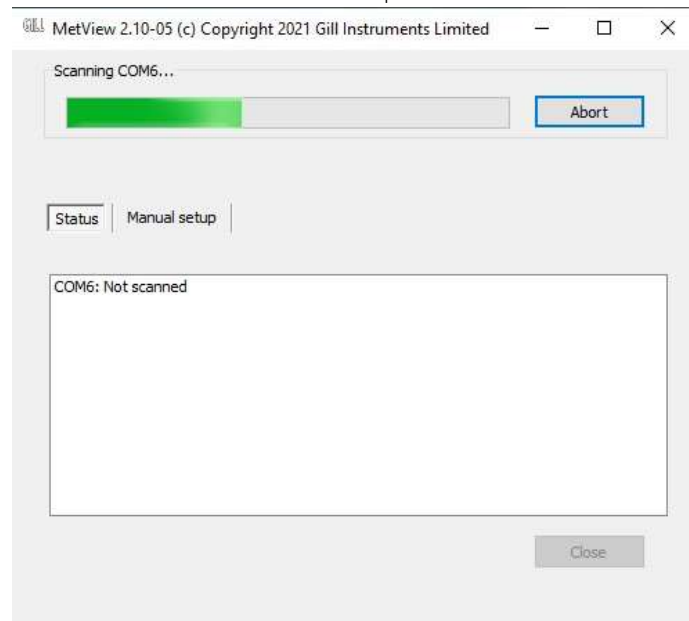

- a. If connect to first device found has been selected then MetView will automatically connect to the MaxiMet on COM Port 6 (connects to lowest numbers first) and open the MaxiMet Marine data view screen showing all of the MaxiMet Marine parameters that have been enabled as outputs.
- b. If Connect to first device found is deselected then click on the Scan button. MetView will then allow the required MaxiMet Marine connection to be made using the blue background highlighted drop down menu.

# MaxiMet<sup>®</sup> Marine

## GMX560 Compact Weather Station

2. Select Connect to go to the data view screen.
3. To select the other MaxiMet Marine then in the data view screen select the Disconnect button and use the drop-down menu below to select and connect to the new MaxiMet Marine.

MetView 2.11-01 (c) Copyright 2023 Gill Instruments Limited



GILL

**MetView**

English

The screenshot shows the MetView software interface. At the top, it displays the GILL logo and the MetView title. Below this is a large banner with the text "Viewing Software" and images of three weather stations: MaxiMet, MetConnect, and MetPak. To the right of the banner are three buttons: "Connect", "Troubleshoot", and "Rescan". Below these buttons is a section titled "Select a configuration file". At the bottom of the interface, there are two input fields: "Select a configuration file" and "Select the sensor that you would like to connect to". The second field contains the text "COM4: UNKNOWN\_DEVICE @baud: 9600".

# MaxiMet<sup>®</sup> Marine

## GMX560 Compact Weather Station

### The MetView Console

When connected correctly, MetView displays its data-monitoring console. This consists of gauges for all of MaxiMet Marine enabled parameters.

Buttons beneath each of the gauges allow you to choose the displayed units and other options. Each gauge also shows the maximum and minimum values recorded during the current session. The wind speed gauge also shows the maximum gust speed.



MetView will not show data if the unit is set for Modbus or SDI-12 format.

An example MetView screen (part of) is shown below (default output).

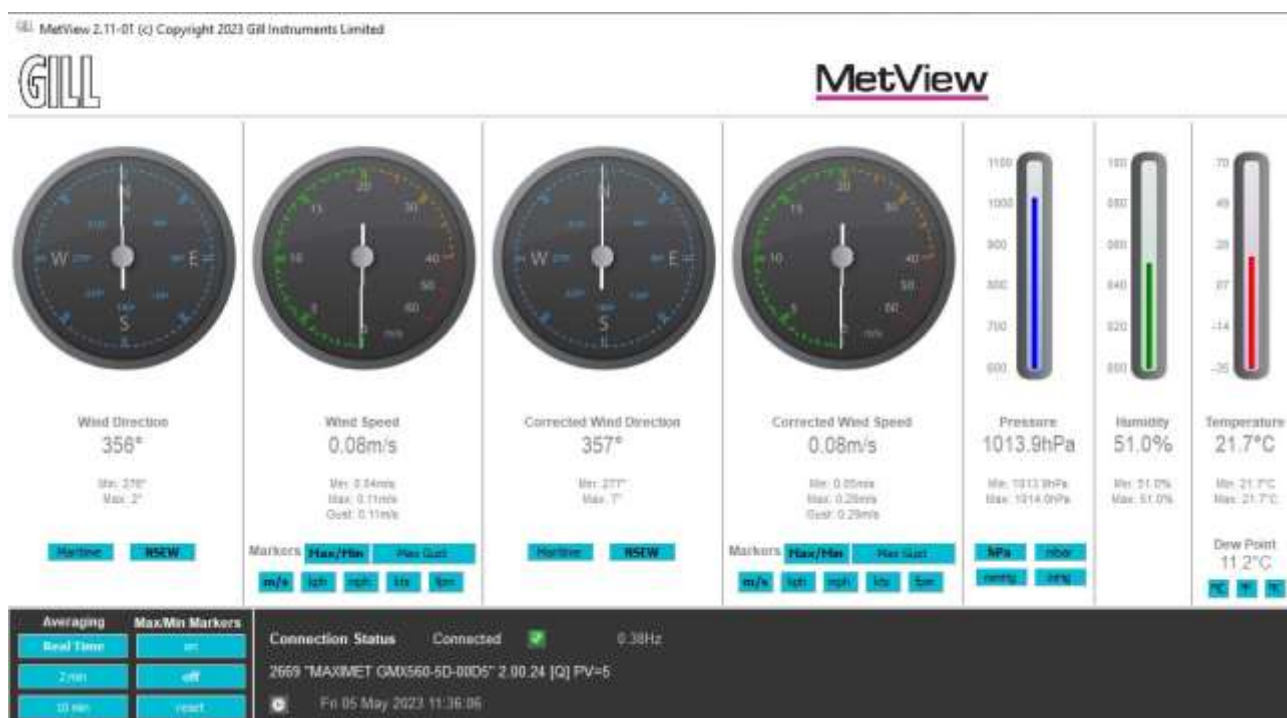

### Connection status indicators

Reading	Function
Green Background Tick	Indicates that the MaxiMet Marine is logging or communicating with MetView correctly, as well as reading the MaxiMet Marine firmware version.
Red Background Cross	Indicates that the MaxiMet Marine is not logging or connected/communicating with MetView.
1.00Hz	Indicates the output rate of the MaxiMet Marine when connected. Reads when the unit is communicating correctly with MetView.
Wed 05 Aug 2015 12:34:45	Real time PC date and time indication.

# MaxiMet<sup>®</sup> Marine

## GMX560 Compact Weather Station

Remaining MetView default output screen shown below

GPS Location 50.763060°lat -1.540148°lon 2.6m	Date and Time 2023-05-05 09:34:29.3	Status 0004
--	---	----------------

Load Log Disabled  
Save Disconnect  
Default



No gauges are associated with the above digital readouts.

The order in which the instruments are shown in the MetView display reflects the order in which the instrument data appears in the MaxiMet Marine data string.

# MaxiMet<sup>®</sup> Marine

## GMX560 Compact Weather Station

### MetView Console Display Options

Units shown in bold on the MetView screen denote default settings.

### MetView Scale and Units of Measure Options

MetView Console buttons can convert data from the MaxiMet Marine to read different units of measure or scale settings, or in the case of Wind readings the type of display (e.g. Maritime, NSEW).

On-screen MetView settings do not alter the actual MaxiMet Marine configuration settings or MaxiMet logged data parameters and units of measure.

### MetView Averaging Options

Setting	Function
Real Time	Choose this button for no averaging
2 Min	Select for on screen 2 minute rolling average for all sensor readings
10 Min	Select for on screen 10 minute rolling average of all sensor readings

### MetView Max/Min Markers

Setting	Function
Off	Maximum and Minimum Markers on all applicable gauges turned off
On	Maximum and Minimum Markers on all applicable gauges turned on
Reset	Reset all applicable gauge Maximum/Minimum Markers and all digital Maximum/Minimum reading at will

### MetView Screen Settings Options

Setting	Function
Save Settings	Will save all the current MetView screen settings to a file location as a .msf file for later retrieval if required.
Load Settings	Will load and update the MetView screen with a previously saved .msf file setting. For use when only a MaxiMet Marine transmit connection is available
Default Settings	Will return all MetView screen settings to factory default.

# MaxiMet<sup>®</sup> Marine

## GMX560 Compact Weather Station

### MetView Gauge/Graphs Range Settings

MetView thermometer style gauge ranges may be altered to view changes in sensor readings more visibly. These changes only affect MetView settings and do not affect the MaxiMet Marine output or logged data. For instance, if the typical Temperature measurement range required is from 0 to +30 °C then the temperature gauge range can be adjusted to reflect this.

1. Place the mouse pointer over the Temperature display gauge and double click to bring up the Set Gauge Range screen. Change Min and Max readings to the required values, e.g. Min: 0, Max: +30.
2. Click on Set. The Temperature gauge range will be updated to reflect the change.

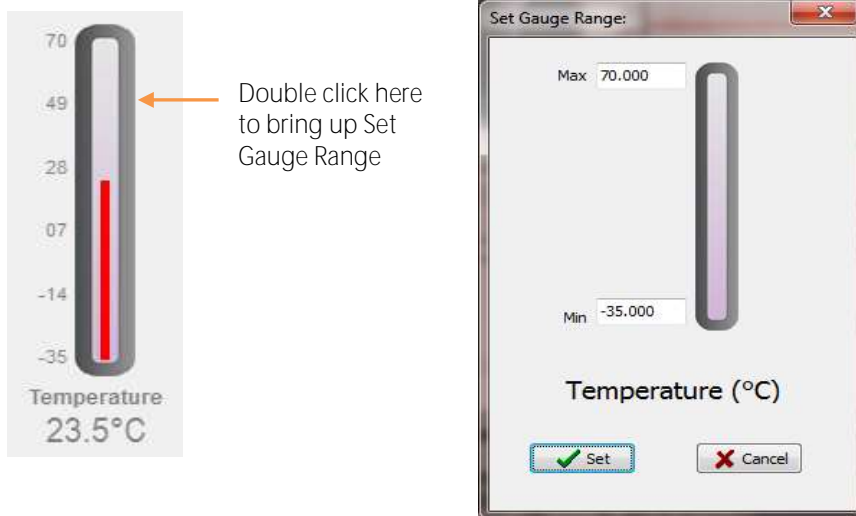

- 1 Open Set Gauge Range window by double clicking on the display

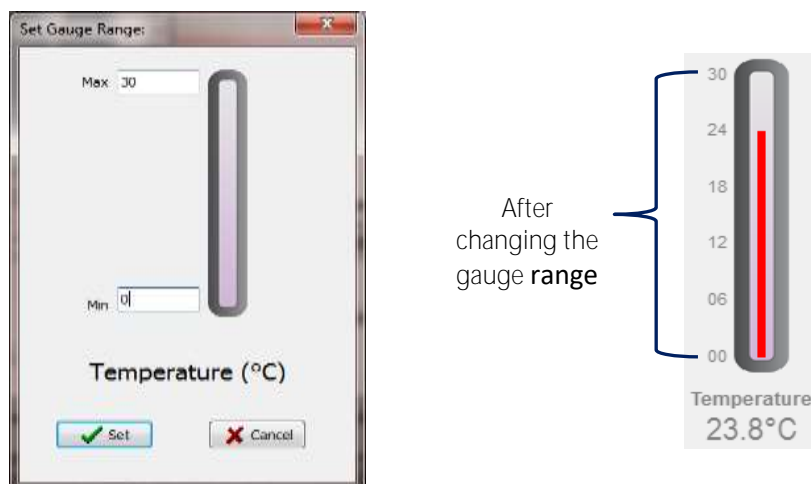

- 2 Change Max and Min values as required and click Set to update **the display gauge**



# MaxiMet<sup>®</sup> Marine

## GMX560 Compact Weather Station

### Graphs

MetView allows data detected over the last minute, last 1 hour and last 24 hours to be accessed and shown on a graph.



Data is only shown up to the time when the graph function is selected; the graph is not updated once opened. Data is collected from the time that MetView is opened and reading data from a MaxiMet Marine.



Double click on the reading to bring up the graph

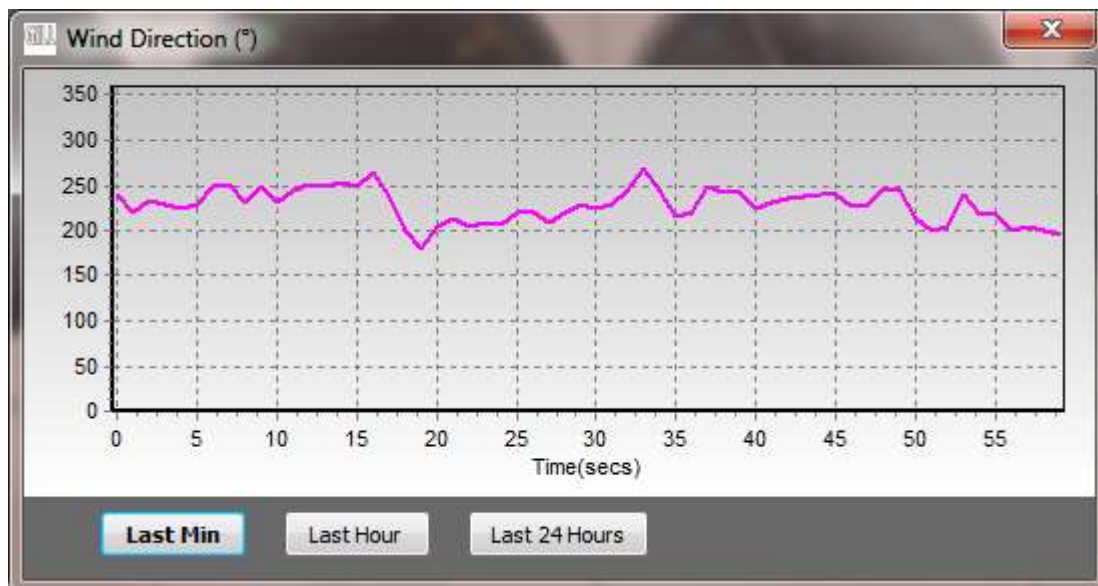

Click on the Last Min, Last Hour or Last 24 Hours buttons as required to view data.

# MaxiMet<sup>®</sup> Marine

## GMX560 Compact Weather Station

### Data Logging



MetView logs data based on the MaxiMet Marine configuration not on the MetView console settings. To start, click on the Log disabled button  on the open MetView console. The Logging dialog box is displayed.

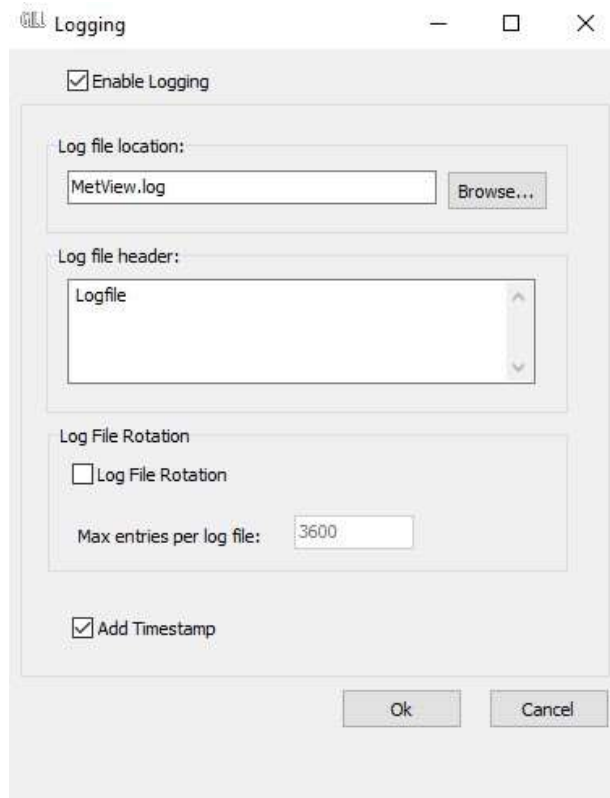

- Set up a logging file: Select Enable Logging (adds a tick to the box).
- Log file location: Click on the Browse button to identify the folder where you want to store the data file. Enter the name of the file.
- Log file header: If required, type some notes on the data that is to be recorded which will appear at the top of the saved data log file.
- Log file rotation: Set up segmented logging with each logged file length determined by the number entered in the text box below. The figure 3600, for example, means that each log file length will be 3600 lines of data. The maximum number of entries per log file is limited to 65535 and a maximum of 2048 log files can be created.
- Add timestamp: Select to add date and time to the logged data file taken from the PC clock.
- To start logging: Check that the Enable Logging option is selected.  
Click on the OK button to commence logging and return to the console.

# MaxiMet<sup>®</sup> Marine

## GMX560 Compact Weather Station



To show that data is being recorded the Logging buttons will change from LOG DISABLED to LOG ENABLED, as displayed below.



To stop logging:

Click on the Log Enabled button on the MetView console. Clear the Enable Logging check box.

Click on the OK button. If logging has stopped, the Logging button shows a red-background cross instead of the green-background tick (see above).

An example of the logged MaxiMet data .log file opened by Notepad is shown below:

```
MaxiMet 600 log000173.log - Notepad
File Edit Format View Help
Log File
000000, Tue 28 July 2015 02:48:58, -0.332,000,02.506,000,000,00,000,000,00,500,0000,1005,9,1005,9,044,+021,1,+008,8,08,35,00000,0,000,0,N,312,2015-07-28T02:46:52.8,+05,1,0000,-77
000001, Tue 28 July 2015 02:48:57, -0.349,000,03.301,000,000,00,000,00,000,0000,1005,9,1005,9,044,+021,1,+008,8,08,36,00000,0,000,0,N,312,2015-07-28T02:46:53.8,+05,1,0000,-79
000002, Tue 28 July 2015 02:48:58, -0.346,000,02.798,000,000,00,000,00,000,0000,1005,9,1005,9,044,+021,1,+008,8,08,35,00000,0,000,0,N,312,2015-07-28T02:46:54.8,+05,1,0000,-75
000003, Tue 28 July 2015 02:48:59, -0.008,000,02.320,000,000,00,000,00,000,0000,1005,9,1005,9,044,+021,1,+008,8,08,35,00000,0,000,0,N,312,2015-07-28T02:46:55.8,+05,1,0000,-76
000004, Tue 28 July 2015 02:49:00, -0.027,000,02.339,000,000,00,000,00,000,0000,1005,9,1005,9,044,+021,1,+008,8,08,35,00000,0,000,0,N,312,2015-07-28T02:46:56.8,+05,1,0000,-78
000005, Tue 28 July 2015 02:49:01, -0.034,000,02.346,000,000,00,000,00,000,0000,1005,9,1005,9,044,+021,1,+008,8,08,35,00000,0,000,0,N,312,2015-07-28T02:46:57.8,+05,1,0000,-75
000006, Tue 28 July 2015 02:49:02, -0.016,000,02.339,000,000,00,000,00,000,0000,1005,9,1005,9,044,+021,1,+008,8,08,35,00000,0,000,0,N,312,2015-07-28T02:46:58.8,+05,1,0000,-70
000007, Tue 28 July 2015 02:49:03, -0.016,000,03.329,000,000,00,000,00,000,0000,1005,9,1005,9,044,+021,1,+008,8,08,35,00000,0,000,0,N,312,2015-07-28T02:46:59.8,+05,1,0000,-72
000008, Tue 28 July 2015 02:49:04, -0.000,000,03.312,000,000,00,000,00,000,0000,1005,9,1005,9,044,+021,1,+008,8,08,35,00000,0,000,0,N,312,2015-07-28T02:47:00.8,+05,1,0000,-73
000009, Tue 28 July 2015 02:49:05, -0.338,000,03.210,000,000,00,000,00,000,0000,1005,9,1005,9,044,+021,1,+008,8,08,35,00000,0,000,0,N,312,2015-07-28T02:47:01.8,+05,1,0000,-76
000010, Tue 28 July 2015 02:49:06, -0.353,000,03.306,000,000,00,000,00,000,0000,1005,9,1005,9,044,+021,1,+008,8,08,35,00000,0,000,0,N,312,2015-07-28T02:47:02.8,+05,1,0000,-72
000011, Tue 28 July 2015 02:49:07, -0.005,000,03.318,000,000,00,000,00,000,0000,1005,9,1005,9,044,+021,1,+008,8,08,35,00000,0,000,0,N,312,2015-07-28T02:47:03.8,+05,1,0000,-76
000012, Tue 28 July 2015 02:49:08, -0.010,000,02.342,000,000,00,000,00,000,0000,1005,9,1005,9,044,+021,1,+008,8,08,35,00000,0,000,0,N,312,2015-07-28T02:47:04.8,+05,1,0000,-73
000013, Tue 28 July 2015 02:49:09, -0.018,000,02.349,000,000,00,000,00,000,0000,1005,9,1005,9,044,+021,1,+008,8,08,35,00000,0,000,0,N,312,2015-07-28T02:47:05.8,+05,1,0000,-77
000014, Tue 28 July 2015 02:49:10, -0.021,000,03.341,000,000,00,000,00,000,0000,1005,9,1005,9,044,+021,1,+008,8,08,35,00000,0,000,0,N,312,2015-07-28T02:47:06.8,+05,1,0000,-73
000015, Tue 28 July 2015 02:49:11, -0.017,000,03.329,000,000,00,000,00,000,0000,1005,9,1005,9,044,+021,1,+008,8,08,35,00000,0,000,0,N,312,2015-07-28T02:47:07.8,+05,1,0000,-76
000016, Tue 28 July 2015 02:49:12, -0.017,000,02.329,000,000,00,000,00,000,0000,1005,9,1005,9,044,+021,1,+008,8,08,35,00000,0,000,0,N,312,2015-07-28T02:47:08.8,+05,1,0000,-76
000017, Tue 28 July 2015 02:49:13, -0.016,000,02.318,000,000,00,000,00,000,0000,1005,9,1005,9,044,+021,1,+008,8,08,35,00000,0,000,0,N,312,2015-07-28T02:47:09.8,+05,1,0000,-75
000018, Tue 28 July 2015 02:49:14, -0.011,000,02.314,000,000,00,000,00,000,0000,1005,9,1005,9,044,+021,1,+008,8,08,35,00000,0,000,0,N,312,2015-07-28T02:47:10.8,+05,1,0000,-77
000019, Tue 28 July 2015 02:49:15, -0.005,000,03.318,000,000,00,000,00,000,0000,1005,9,1005,9,044,+021,1,+008,8,08,35,00000,0,000,0,N,312,2015-07-28T02:47:11.8,+05,1,0000,-79
000020, Tue 28 July 2015 02:49:16, -0.011,000,03.323,000,000,00,000,00,000,0000,1005,9,1005,9,044,+021,1,+008,8,08,35,00000,0,000,0,N,312,2015-07-28T02:47:12.8,+05,1,0000,-74
000021, Tue 28 July 2015 02:49:17, -0.013,000,02.316,000,000,00,000,00,000,0000,1005,9,1005,9,044,+021,1,+008,8,08,35,00000,0,000,0,N,312,2015-07-28T02:47:13.8,+05,1,0000,-76
000022, Tue 28 July 2015 02:49:18, -0.016,000,03.328,000,000,00,000,00,000,0000,1005,9,1005,9,044,+021,1,+008,8,08,35,00000,0,000,0,N,312,2015-07-28T02:47:14.8,+05,1,0000,-74
000023, Tue 28 July 2015 02:49:19, -0.014,000,03.326,000,000,00,000,00,000,0000,1005,9,1005,9,044,+021,1,+008,8,08,35,00000,0,000,0,N,312,2015-07-28T02:47:15.8,+05,1,0000,-77
000024, Tue 28 July 2015 02:49:20, -0.334,000,03.306,000,000,00,000,00,000,0000,1005,9,1005,9,044,+021,1,+008,8,08,35,00000,0,000,0,N,312,2015-07-28T02:47:16.8,+05,1,0000,-73
000025, Tue 28 July 2015 02:49:21, -0.351,000,03.305,000,000,00,000,00,000,0000,1005,9,1005,9,044,+021,1,+008,8,08,35,00000,0,000,0,N,312,2015-07-28T02:47:17.8,+05,1,0000,-74
000026, Tue 28 July 2015 02:49:22, -0.022,000,03.315,000,000,00,000,00,000,0000,1005,9,1005,9,044,+021,1,+008,8,08,35,00000,0,000,0,N,312,2015-07-28T02:47:18.8,+05,1,0000,-78
000027, Tue 28 July 2015 02:49:23, -0.010,000,02.322,000,000,00,000,00,000,0000,1005,9,1005,9,044,+021,1,+008,8,08,35,00000,0,000,0,N,312,2015-07-28T02:47:19.8,+05,1,0000,-74
```

# MaxiMet<sup>®</sup> Marine

## GMX560 Compact Weather Station

### Use a Terminal Program to View the MaxiMet Data String

There are many terminal programs that might be used to view the MaxiMet data string, e.g. HyperTerminal, Putty, Tera Term etc.

If, for example, Tera Term is used:

1. Open Tera Term.
2. Select Serial.
3. Select MaxiMet connected COM port.
4. Click on OK.

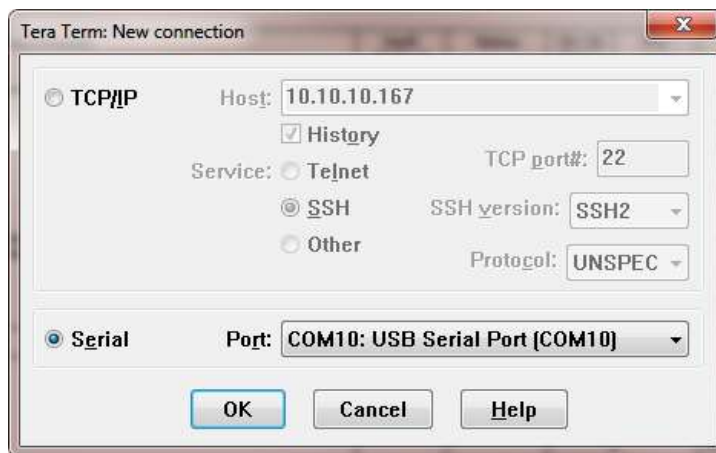

5. Tera Term opens at 9600 baud by default but MaxiMet Marine uses 19200 as a default, so change Tera Term baud rate setting to 19200.

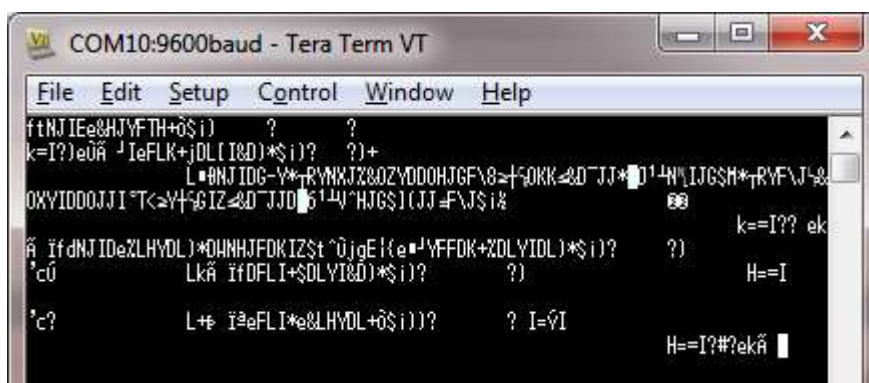

# MaxiMet<sup>®</sup> Marine

## GMX560 Compact Weather Station

- Select Setup from the top menu.
- Click on Serial Port from the drop down menu.
- Change baud rate to 19200.
- Click on OK.

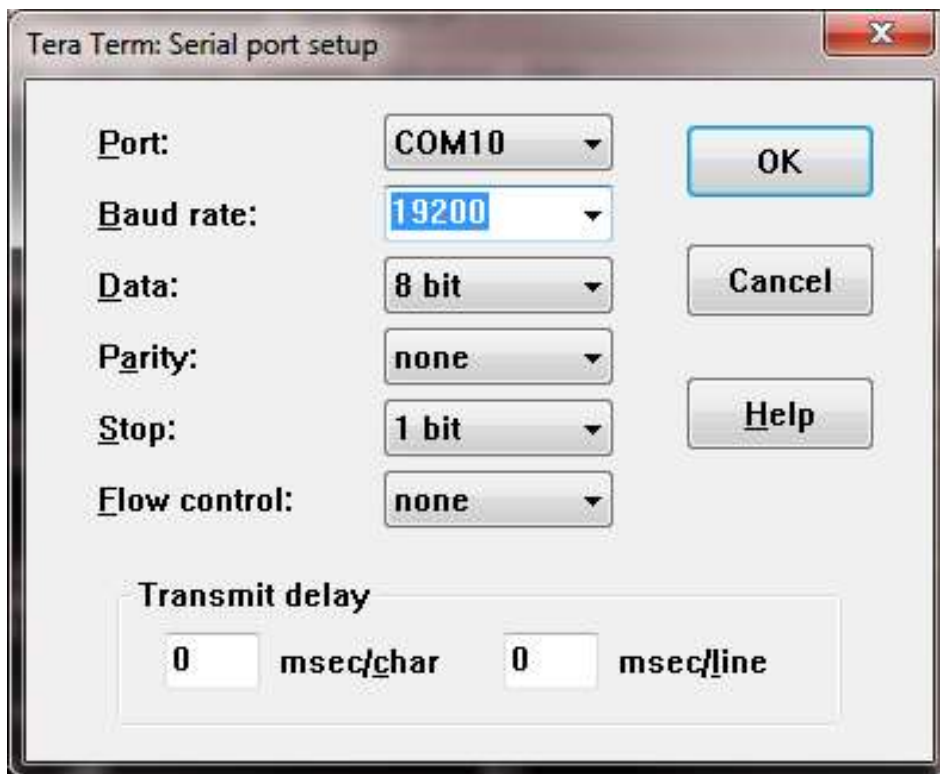

Data will be output as follows:

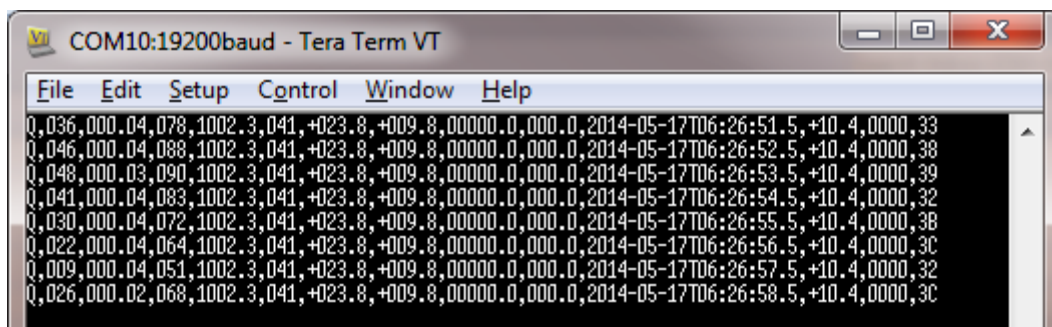

# MaxiMet<sup>®</sup> Marine

## GMX560 Compact Weather Station

### Creating a logging file

1. Select File > Log.
2. Select Save in destination, e.g. Desktop.
3. Add the name for the log file in File Name, e.g. teraterm.
4. Tick options as required e.g. Timestamp.
5. Click on Save.

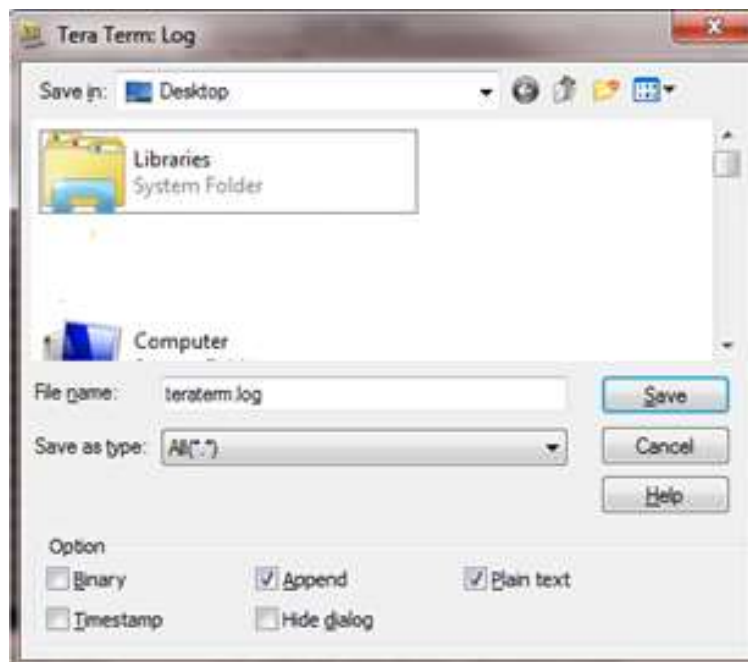

# MaxiMet<sup>®</sup> Marine

## GMX560 Compact Weather Station

- The following dialog box will open on the PC desktop.

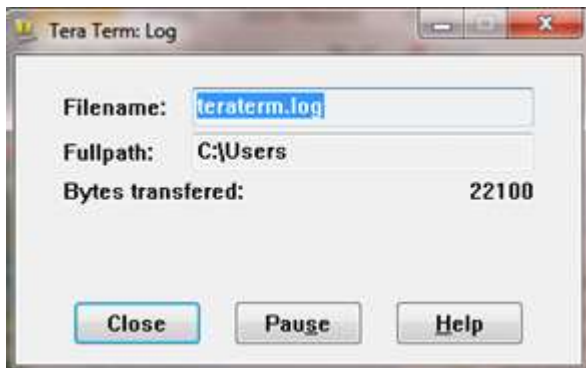

- To stop logging, click on the Close button.

### Understanding Logged Data

Logged data is stored to a file with a .log extension. This can be viewed in any text/HTML editor or spreadsheet application.

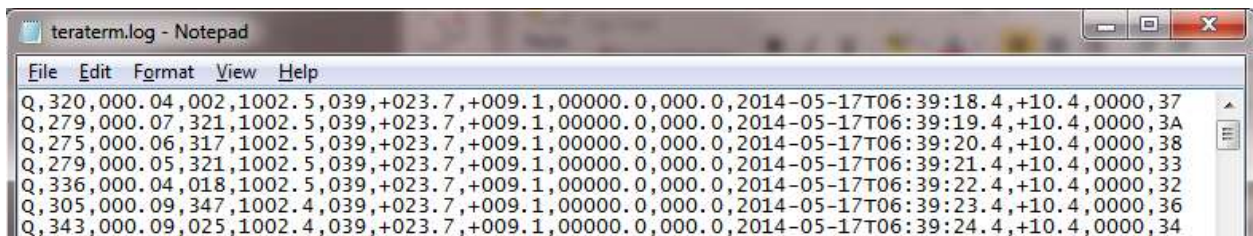

# MaxiMet<sup>®</sup> Marine

## GMX560 Compact Weather Station

### Appendix L - Maintenance & fault-finding

#### Cleaning and Handling

Ideally when installing the unit handle with lint free gloves and degrease the unit to reduce the build-up of deposits.

#### Servicing

There are no moving parts requiring routine maintenance.

Opening the unit or breaking the security seal will void the warranty and the calibration.

In the event of failure, prior to returning the unit to your authorised Gill distributor, it is recommended that:

- All cables and connectors are checked for continuity, bad contacts, corrosion etc.
- A bench test is carried out.
- Contact your supplier for advice if failure persists.

#### Compass/GPS Modules

The compass and GPS module devices are maintenance-free. If required, return the MaxiMet Marine to Gill Instruments to check the compass and GPS operation (see page 84. for details about returning the unit).

#### Wind Sensor (WindSonic)



If there is any build-up of deposits on the unit, it should be gently cleaned with a cloth, moistened with soft detergent. Solvents should not be used, and care should be taken to avoid scratching any surfaces. The unit must be allowed to defrost naturally after being exposed to snow or icy conditions, DO NOT attempt to remove ice or snow with a tool.

There are no moving parts or user-serviceable parts requiring routine maintenance.

Opening the unit or breaking the security seal will void the warranty and the calibration.

#### Barometer

The barometer device is located internally and is not maintainable or replaceable by a user.

Consideration should be given to checking the Pressure readings against a standard every 12 months. If required, return the MaxiMet to Gill Instruments to check the barometer calibration (see page 86) for details about returning the unit).

#### UV Shield (MetSpec)



Ideally the user should try to keep MaxiMet radiation screens clean and free of biological growth but a simple wipe with some non-aggressive soft detergent cleaner will suffice. Solvents should not be used, and care should be taken to avoid scratching any surfaces. The unit must be allowed to defrost naturally after being exposed to snow or icy conditions, DO NOT attempt to remove ice or snow with a tool.



# MaxiMet<sup>®</sup> Marine

## GMX560 Compact Weather Station

### Temperature, Humidity and Dewpoint

The internal temperature and humidity sensor is not user-maintainable. If used in areas of high pollution or marine environments then consideration should be given to returning the unit for maintenance at Gill instruments every 12 to 24 months to ensure proper performance (see page 84) for details about returning the unit).

### Calibration

A calibration check can be done by any user/distributor by comparing the values measured by MaxiMet Marine with a reference value or in an environmental chamber. Users should understand that these checks are not the same as the calibration checks or calibration done at Gill but they can provide users with some degree of confidence to the validity of their measurements. If a user/distributor notices a significant difference between the MaxiMet Marine and their test environment/reference they should contact Gill to discuss this and see if a calibration is required. See individual parts

### Fault-finding

Symptom	Solution
No output.	Check DC power to MaxiMet Marine, cable and connections. Check communications settings of the MaxiMet Marine and host system match, including correct COM port. Check that the unit is in continuous mode. Check that in-line communication devices are wired correctly.  It is usual for anemometer TX + to be connected to converter device RX +. If appropriate use Safe Mode to attempt to obtain communication with the MaxiMet Marine.
Corrupted output.	Check that the communication settings of the MaxiMet Marine and host system match. Try a slower baud rate. Check cable lengths and type of cable. Check for sources of external signal interference.
One-way communication.	Check that the wiring is in accordance with the manual.
Unexpected Temperature /Dewpoint readings.	Check that the Temperature and Dewpoint units of measure (C, F, K) settings are correct on power up.
Unexpected Wind readings.	Check that the Wind Sensor units of measure (m/s, knots, kph, ft/min, mph) settings are correct on power up.
Unexpected Temperature/Dewpoint and Humidity readings.	Temperature and Humidity Device faulty.
Unexpected Barometer Readings.	Check units of measure are set correctly and if offset HASTN or PSTN readings have been applied.
Status code not 0000 or A.	See following tables.

## GMX560 Compact Weather Station

### Sensor Status Codes

Code	Status	Condition
0000	OK.	No fault conditions detected in measurement period.
0001	Wind measurement fault.	Wind Sensor faulty.
0002	GPS error.	E.g. Locating Satellite fix.
0004	Source for Corrected Wind Direction is GPS.	GPS notification.
0006	GPS Location missing.	GPS error.
0008	Tilt measurement fault.	Tilt error.
0010	Temperature measurement fault.	Temperature sensor faulty.
0020	Dewpoint fault.	If Temperature and Humidity are reporting correctly then this code indicates a main PCB fault.
0040	Humidity fault.	Humidity sensor faulty.
0080	Pressure sensor warning.	Pressure sensor reading not available/unit faulty.
0100	Compass fault.	Invalid heading due to compass fault.
8000	Heating Error	A problem with heating has been detected.
XX	More than one fault	Fault condition that can be the sum of any of the above eg 11 would mean that both the Wind Sensor (0001) and Temperature (0010) were faulty.

### Wind Status Codes

Code	Status	Condition
0000	OK.	No fault conditions detected in measurement period.
0001	Wind sensor - axis failed.	Wind axis U blocked or faulty.
0002	Wind sensor - axis failed.	Wind axis V blocked or faulty.
0004	Wind sensor - both axes failed.	Wind axes U and V blocked or faulty.
0008	Wind Sensor NVM Failure	Non-Volatile Memory checksum failed; data could be uncalibrated
0009	Wind Sensor ROM Failure	Read Only Memory checksum failed, data could be uncalibrated
0100	Wind Average building.	WMO wind average building.
0200	Corrected Wind measurement not available.	Compass corrected wind measurement failure.
A	NMEA acceptable data.	No fault conditions detected in measurement period
V	NMEA void data.	Fault condition detected in measurement period.

# MaxiMet<sup>®</sup> Marine

## GMX560 Compact Weather Station

### Heater Status Code

HEATSTAT must be set as a parameter for this information to be output.

Code	Status	Condition
0000	Heating Off	Indicates heating is not on
0001	Heating On	Indicates heating is on
0002	Heating Inhibited	Indicates heating is prevented from coming on
0004	Heating Current Detected	Indicates current is flowing in the heater circuit
0008	Power Up Test Timer	Indicates heating is on for a short period after power on
0010	Supply Low During Surge Period	Indicates the supply voltage has dropped below the minimum as a result of the heating being on.
0020	No Current Detected	Indicates no current detected when heating was turned on.
0040	Heating Supply Too High	Voltage is too high for heating
0080	Heating Supply Too Low	Voltage is too low for heating
0100	Ambient Temperature Invalid	Replace humidity/temperature sensor

### Safe Mode

If a unit is received that will not communicate or the configuration settings are not known, then Safe Mode can be used to establish communication with the MaxiMet Marine and change configuration settings (see Appendix H).

### Bench Test

See para-3.11

### Returning Units

If the unit has to be returned, it should be carefully packed in the original packaging and returned to your authorised Gill distributor, with a full description of the fault condition. An RMA number should be obtained from Gill Instruments first if returning directly to Gill Instruments.

### Guarantee

For terms of guarantee contact your supplier or refer to the Gill Instruments Terms & Conditions here:

<https://gill.group/wp-content/uploads/Gill-Group-Company-Terms-Conditions-of-Sale-9170-0003-Issue-02-March-20...pdf>

### Appendix M - MaxiMet Output Parameters selectable using MetSet Software



Not in order of output, see Appendix C for applicability and Appendix D for MetSet set up.

#### NODE - Node Letter

MaxiMet identifying Node letter at beginning of the data string.

Result e.g. Q (default).

#### SPEED -Wind Speed

Wind Speed measurement.

Result e.g. 001.05 (metres/second default).

#### CSPEED -Corrected Speed

Corrected Wind Speed shall be computed as the True Wind Speed (i.e.: using GPS Speed, GPS Heading and Compass Heading) when all three of GPS Speed, GPS Heading and Compass Heading are available.

Result e.g. 003.17 (metres/second default).

Corrected Wind Speed shall not be computed when any one (or more) of GPS Speed, GPS Heading and Compass Heading are unavailable.

Corrected Wind Speed shall not be computed when Compass Heading is unavailable.

The Gill Algorithm for generating Corrected Speed based on Compass heading is as follows:-

1. Convert Magnitude and Direction to UV.
2. Calculate applied wind in UV due to movement from GPS.
3. Calculate Corrected UV as difference between Relative and GPS wind.
4. Convert UV back to Magnitude and Direction.

## GMX560 Compact Weather Station

### GSPEED (WMO) - *Gust Speed*

Outputs WMO Gust Speed.

Maximum Gust Magnitude shall be computed over a block of  $m$  gust magnitudes as follows:

$$rwa\_max\_gust\_mag = \max \{gust\_mag_1, gust\_mag_2 \dots gust\_mag_m\}$$

Where:  $m = rwa\_short\_len$

$$gust\_mag = \sqrt{u\_avg^2 + v\_avg^2}$$

$$u\_avg = \frac{\sum_{n=1}^3 u\_vector_n}{3}$$

$$v\_avg = \frac{\sum_{n=1}^3 v\_vector_n}{3}$$

Result e.g. 015.15 (metres/second default).

### CGSPEED - *Corrected Gust Speed*

GPS corrected Gust Speed.

Result e.g. 011.05 (metres/second default).

### AVGSPEED (WMO) - *Average Speed*

Outputs the World Meteorological Organisation (WMO) Average Wind Speed reading based on AVG short and AVG long settings (see Page 37).

Result e.g. 001.45 (Metres/second default).

A short term average magnitude shall be computed every  $rwa\_short\_len$  samples as follows:

$$mag\_st = \sqrt{u\_st^2 + v\_st^2}$$

Where:  $u\_st = \frac{\sum_{n=1}^N u\_vector_n}{N}$

$$v\_st = \frac{\sum_{n=1}^N v\_vector_n}{N}$$

$u\_vector_n = nth$  calibrated  $u$ -vector generated at " $P$ "-rate

$v\_vector_n = nth$  calibrated  $v$ -vector generated at " $P$ "-rate

$N = rwa\_short\_len$

## GMX560 Compact Weather Station

### AVGCSPEED (WMO) -Average Corrected Speed

Outputs the World Meteorological Organisation (WMO) Average Wind Speed reading based on AVG short and AVG long settings (see page 37).

Result e.g. 001.45 (metres/second default).

### DIR - Direction

Wind Direction relative to the MaxiMet north marker.

Result e.g. 132 (degrees).

### CDIR - Corrected Direction

Corrected Wind Direction shall be computed as the Apparent Wind Direction (i.e.: using Compass Heading) when Compass Heading is available but any one (or more) of GPS Speed and GPS Heading are unavailable.

Corrected Wind Direction shall be computed as the True Wind Direction (i.e.: using GPS Speed, GPS Heading and Compass Heading) when all three of GPS Speed, GPS Heading and Compass Heading are available.

Result e.g. 116 (degrees).

Corrected Wind Direction shall not be computed when Compass Heading is unavailable.

The Gill Algorithm for generating Corrected Direction based on Compass heading is as follows:-

1. Convert Magnitude and Direction to UV.
2. Calculate applied wind in UV due to movement from GPS.
3. Calculate Corrected UV as difference between Relative and GPS wind.
4. Convert UV back to Magnitude and Direction.

### GDIR (WMO) - Gust Direction

Outputs WMO Gust Direction.

Maximum Gust Direction shall be computed over a block of m vector averages as follows:

$$rwa\_max\_gust\_dir = \arctan\left(\frac{u\_avg_k}{v\_avg_k}\right)$$

Where:  $k$  = index of  $gust\_mag$  selected for  $rwa\_max\_gust\_mag$  defined above

$$u\_avg_k = k^{th} \text{ u-vector average defined above}$$

$$v\_avg_k = k^{th} \text{ v-vector average defined above}$$

Result e.g. 123 (degrees).

## GMX560 Compact Weather Station

### CGDIR - Corrected Gust Direction

GPS corrected Gust Direction.

Result e.g. 135 (degrees).

### AVGDIR (WMO) - Average Direction

Outputs WMO Average Direction Wind reading based on AVG short and AVG long settings (see page 62).

Result e.g. 145 (degrees).

A short-term average direction shall be computed every `rwa_short_len` samples as follows:

$$dir\_st = \arctan\left(\frac{u\_st}{v\_st}\right)$$

Where:  $u\_st$  = short-term average  $u$  – vector defined above

$v\_st$  = short-term average  $v$  – vector defined above

A long term average direction shall be computed every `rwa_long_len` samples as follows:

$$rwa\_direction = \arctan\left(\frac{u\_lt}{v\_lt}\right)$$

Where:  $u\_lt = \frac{\sum_{n=1}^M u\_st_n}{M}$

$$v\_lt = \frac{\sum_{n=1}^M v\_st_n}{M}$$

$u\_st_n$  =  $n$ th short-term  $u$ -vector average defined above

$v\_st_n$  =  $n$ th short-term  $v$ -vector average defined above

### AVGCDIR (WMO) - Average Corrected Direction

Outputs WMO average Compass Corrected Direction wind reading based on AVG short and AVG long settings (see page 62).

Result e.g. 131 (degrees).

### PRESS - Pressure

Outputs the MaxiMet Pressure reading.

Result e.g. 1021.3 (hectopascals default).

## GMX560 Compact Weather Station

### PASL Pressure at Sea Level

Outputs Barometric Pressure at Sea Level if HASL figure set (see page 64).

$$P = Pb \left( \frac{Tb}{Tb + Lb \times (-h)} \right)^{\frac{g0 \times M}{R \times Lb}}$$

Where:  $P$  = adjusted pressure

$Pb$  = pressure (pascals) - as measured by the pressure sensor

$Tb$  = temperature (K)

$Lb$  = standard temperature lapse rate (K/m) in ISA. For the Troposphere this is assumed to be -0.0065 Kelvin/metre.

$h$  = height (meters) = sensor's height above (or below) sea level, i.e. 'Height Above Sea Level' plus 'Height Above Station'

$R$  = universal gas constant for air: 8.31432 N·m/(mol·K)

$g0$  = gravitational acceleration (9.80665 m/s<sup>2</sup>)

$M$  = molar mass of Earth's air (0.0289644 kg/mol)

Result e.g. 1015.7 (hectopascals default).

### PSTN - Pressure at Station

Outputs Barometric Pressure at Station (which can be positioned anywhere) if HASTN figure set (see below and page 64).

Pressure at station shall be computed as:

$$P = Pb \left( \frac{Tb}{Tb + Lb \times (-h)} \right)^{\frac{g0 \times M}{R \times Lb}}$$

Where:  $P$  = adjusted pressure

$Pb$  = pressure (pascals) - as measured by the pressure sensor

$Tb$  = temperature (K)

$Lb$  = standard temperature lapse rate (K/m) in ISA. For the Troposphere this is assumed to be -0.0065 Kelvin/metre.

$h$  = height (meters) = 'Height Above Station', i.e. the difference between the sensor height above (or below) local ground level.

$R$  = universal gas constant for air: 8.31432 N·m/(mol·K)

$g0$  = gravitational acceleration (9.80665 m/s<sup>2</sup>)

$M$  = molar mass of Earth's air (0.0289644 kg/mol)

Result e.g. 1001.2 (hectopascals default).



# MaxiMet<sup>®</sup> Marine

## GMX560 Compact Weather Station

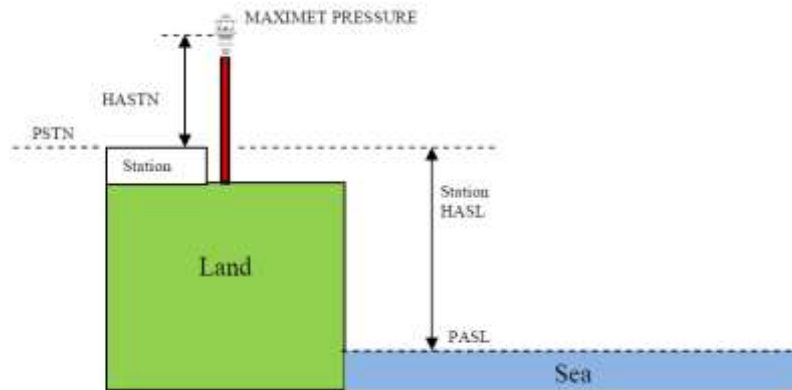

### RH - Relative Humidity

Outputs the measured Relative Humidity reading in %.

Result e.g. 028 (%).

### AH - Absolute Humidity

The humidity of the atmosphere, usually expressed as the number of grams of water contained in 1 cubic metre of air.



Relative Humidity also output, expressed as a percent, measures the current absolute humidity relative to the maximum for that temperature).

Absolute humidity shall be computed as:

$$H = \frac{C \times P_w}{T}$$

Where:  $H$  = absolute humidity

$C$  = Constant 2.16679 gK/J

$P_w$  = Vapour pressure in Pa

$T$  = Temperature in K

Result e.g. 08.14 g/m<sup>3</sup>.

### TEMP - Temperature

Outputs MaxiMet Temperature sensor readings.

Result e.g. 022.0 (°C default).

## GMX560 Compact Weather Station

### DEWPOINT - *Dewpoint*

Outputs calculated Dewpoint from Temperature and Humidity readings.

$$Td = \frac{Tn}{Y - 1}$$

Where:  $Td$  = Dewpoint temperature

$Tn$  = Triple point temperature (in K)

$$Y = \frac{m}{\log_{10} Pw/A}$$

$$Pw = \frac{Pws \cdot RH}{100} \text{ (hPa)}$$

$Pws$  = water vapour saturation pressure (hPa)

Result e.g. +023.1 (°C default).

### WCHILL - *Wind Chill*

The perceived decrease in air temperature felt by the body on exposed skin due to the flow of air.

See WMO Document TD-1184.

$$W = 13.12 + 0.6215 \cdot T_{air} - 11.37 \cdot V_{10\text{metre}}^{0.16} + 0.3965 \cdot T_{air} \cdot V_{10\text{metre}}^{0.16}$$

Where:-

$W$  = the WindChill index based on Celcius Temperature scale.

$T_{air}$  = The air temperature in Degrees Celcius.

$V_{10\text{metre}}$  = the Wind speed at 10 Metres (standard anemometer height) in kilometres/hour.

Result e.g. -012 (°C default).

Note: Wind Chill is only reported when the temperature is below 10°C and the wind speed is at least 1.5m/s.

## GMX560 Compact Weather Station

### HEATIDX - Heat Index

What the temperature feels like to the human body when relative humidity is combined with the air temperature (also known as apparent temperature).

Simple Heat Index is defined as:

$$HI_s = 0.5 * \{T + 61.0 + [(T-68.0)*1.2] + (RH*0.094)\}$$

where:  $HI_s$  = Simple Heat Index expressed as an apparent temperature in degrees F.

$T$  = MaxiMet Temperature in degrees F.

$RH$  = MaxiMet Relative Humidity in percent.

Rothfusz Heat Index is defined as:

$$HI_r = -42.379 + 2.04901523*T + 10.14333127*RH - 0.22475541*T*RH - 0.00683783*T*T - 0.05481717*RH*RH + 0.00122874*T*T*RH + 0.00085282*T*RH*RH - 0.00000199*T*T*RH*RH$$

See [http://www.wpc.ncep.noaa.gov/html/heatindex\\_equation.shtml](http://www.wpc.ncep.noaa.gov/html/heatindex_equation.shtml)

where:  $HI_r$  = Rothfusz Heat Index expressed as an apparent temperature in degrees F.

$T$  = MaxiMet Temperature in degrees F.

$RH$  = MaxiMet Relative Humidity in percent.

Rothfusz Adjustment is defined as follows:

If the Relative Humidity is less than 13% and the Temperature is above 80 and below 112 degrees F (above 26.66 and below 44.44 °C):

$$R_{Adj} = -[(13-RH)/4]*SQRT\{[17-ABS(T-95)]/17\}$$

where:  $R_{Adj}$  = Rothfusz Adjustment,

$T$  = MaxiMet Temperature in degrees F,

$RH$  = MaxiMet Relative Humidity in percent,

ABS and SQRT are the absolute value and square root functions, respectively.

If the Relative Humidity is greater than 85% and the Temperature is above 80 and below 87 degrees F (above 26.66 and below 30.55 °C).

$$R_{Adj} = [(RH-85)/10] * [(87-T)/5]$$

where:  $R_{Adj}$  = Rothfusz Adjustment.

$T$  = MaxiMet Temperature in degrees F.

$RH$  = MaxiMet Relative Humidity in percent.

If Relative Humidity and Temperature conditions are outside the two bands defined above:

$$R_{Adj} = 0$$

where:  $R_{Adj}$  = Rothfusz Adjustment

When  $HI_s \geq (HI_r + R_{Adj})$ , MaxiMet Heat Index shall be:  $HI = HI_s$

where:  $HI$  = MaxiMet Heat Index expressed as an apparent temperature in degrees F,

$HI_s$  = Simple Heat Index expressed as an apparent temperature in degrees F

When  $HI_s < (HI_r + R_{Adj})$ , MaxiMet Heat Index shall be:  $HI = HI_r + R_{Adj}$

where:  $HI$  = MaxiMet Heat Index expressed as an apparent temperature in degrees F,

$HI_r$  = Rothfusz Heat Index expressed as an apparent temperature in degrees F,

$R_{Adj}$  = Rothfusz Adjustment.

Result e.g. +028 (°C default).

## GMX560 Compact Weather Station



Heat Index is only reported when the temperature is above 75°F (approximately 23.88°C) and both Relative Humidity and Temperature are functioning.

### AIRDENS - Air Density

Outputs calculated Air Density from Pressure and Temperature readings.

$$\text{Density} = \frac{P}{R \times T}$$

Where:  $P$  = measured absolute pressure in Pa  
 $R$  = the gas constant (287.05 Jkg<sup>-1</sup>K<sup>-1</sup>)  
 $T$  = Temperature in K

Result e.g. 1.0 (kgm<sup>-3</sup>).

### WBTEMP - Wet Bulb Temperature

The temperature a parcel of air would have if it were cooled to saturation (100% relative humidity) by the evaporation of water into it, with the latent heat being supplied to the parcel.

Result e.g. -012.3 (°C default).

For temperatures between -20 and 50 °C and RH humidity ranges of 5 and 99%, wet bulb temperature shall be computed as:

$$T_w = T \operatorname{atan}[0.151977(\operatorname{RH}\% + 8.313659)^{1/2}] + \operatorname{atan}(T + \operatorname{RH}\%) - \operatorname{atan}(\operatorname{RH}\% - 1.676331) + 0.00391838(\operatorname{RH}\%)^{3/2} \operatorname{atan}(0.023101\operatorname{RH}\%) - 4.686035.$$

where:

$T_w$  = wet bulb temperature in °C,  
 $T$  = air temperature in °C,  
RH% = relative humidity.

Note: The calculation is based on a mean sea level pressure of 1013.25 hPa (according to the International Civil Aviation Organization).

Outside temperatures between -20 °C and 50 °C and RH humidity ranges of 5 and 99%, wet bulb temperature shall not be computed

## GMX560 Compact Weather Station

### TWIC - Twilight Civil

Begins in the morning, or ends in the evening, when the geometric centre of the Sun is 6 degrees below the horizon.

Beginning of Morning Twilight (Civil): Defined as the instant in the morning, when the centre of the Sun is at a depression angle of six degrees (6°) below an ideal horizon. At this time in the absence of moonlight, artificial lighting or adverse atmospheric conditions, the illumination is such that large objects may be seen but no detail is discernible. The brightest stars and planets can be seen and for navigation purposes at sea, the sea horizon is clearly defined.

End of Evening Twilight (Civil): Defined as the instant in the evening, when the centre of the Sun is at a depression angle of six degrees (6°) below an ideal horizon. At this time in the absence of moonlight, artificial lighting or adverse atmospheric conditions, the illumination is such that large objects may be seen but no detail is discernible. The brightest stars and planets can be seen and for navigation purposes at sea, the sea horizon is clearly defined.

Result e.g. 07:10

Note: The installation longitude and latitude must be configured using MetSet for correct readings.

### TWIN - Twilight Nautical

Begins in the morning, or ends in the evening, when the geometric centre of the Sun is 12 degrees below the horizon.

Beginning of Morning Twilight (Nautical): Defined as the instant in the morning, when the centre of the Sun is at a depression angle of twelve degrees (12°) below an ideal horizon. At this time in the absence of moonlight, artificial lighting or adverse atmospheric conditions, it is dark for normal practical purposes. For navigation purposes at sea, the sea horizon is not normally visible.

End of Evening Twilight (Nautical): Defined as the instant in the evening, when the centre of the Sun is at a depression angle of twelve degrees (12°) below an ideal horizon. At this time in the absence of moonlight, artificial lighting or adverse atmospheric conditions, it is dark for normal practical purposes. For navigation purposes at sea, the sea horizon is not normally visible.

Result e.g. 06:28



The installation longitude and latitude must be configured using MetSet for correct readings.

# MaxiMet<sup>®</sup> Marine

## GMX560 Compact Weather Station

### TWIA - Twilight Astronomical

Begins in the morning, or ends in the evening, when the geometric centre of the Sun is 18 degrees below the horizon.

Beginning of Morning Twilight (Astronomical): Defined as the instant in the morning, when the centre of the Sun is at a depression angle of eighteen degrees (18°) below an ideal horizon. At this time the illumination due to scattered light from the Sun is less than that from starlight and other natural light sources in the sky.

End of Evening Twilight (Astronomical): Defined as the instant in the evening, when the centre of the Sun is at a depression angle of eighteen degrees (18°) below an ideal horizon. At this time the illumination due to scattered light from the Sun is less than that from starlight and other natural light sources in the sky.

Result e.g. 05:49



The installation longitude and latitude must be configured using MetSet for correct readings.

### XTILT - X Tilt

X-Tilt shall be displayed in degrees with 2 signed integral digits over the range ±89 degrees.

With respect to the MaxiMet north marker:

+XX shall indicate that the unit is tipping towards east.

-XX shall indicate that the unit is tipping towards west.

Result e.g. +01            -01  
              +10            -10

### YTILT - Y Tilt

Y-Tilt shall be displayed in degrees with 2 signed integral digits over the range ±89 degrees.

+YY shall indicate that the unit is tipping towards north.

-YY shall indicate that the unit is tipping towards south.

Result e.g. +01            -01  
              +10            -10

### ZORIENT - Z Orient

Z-Orientation shall be displayed as +1 or -1.

+1 (normal upright position (+- 90 degrees)).

-1 (inverted position (+- 90 degrees)).

Result e.g. +1            -1

# MaxiMet<sup>®</sup> Marine

## GMX560 Compact Weather Station

### CHECKTILT - *Check Tilt*

Units with an Inclinometer have a more accurate X and Y Tilt 4 Hz output that can be configured with a PC terminal program during installation if required (see para 6.8).

X-Tilt shall be displayed in degrees with up to 2 integral digits and a decimal point over the range 89.9°/-89.9°.

Result e.g.	88.9	-88.9
	8.9	-8.9
	0.9	-0.9

Y-Tilt shall be displayed in degrees with up to 2 integral digits and a decimal point over the range 89.9°/-89.9°.

Result e.g.	88.9	-88.9
	8.9	-8.9
	0.9	-0.9

Z-Orientation shall be displayed as 1 (upright) or -1 (inverted).

Result e.g.	1	-1
-------------	---	----

Compass Heading shall be displayed in degrees (000-359) on wind output units.

Result e.g. 001.

### COMPASSH - Compass Heading

North direction read out from the MaxiMet compass.

### GPSHEADING - GPS Enabled Heading

GPS Heading shall be displayed with 3 integral digits.

Result e.g. 064 (degrees).

### GPSSPEED - GPS Speed over Ground

Velocity at which the MaxiMet unit with GPS is travelling over ground.

Result e.g. +000.10 (metres/second (default)).

In feet/minute setting then a reading might be 00020 (no decimal places).

### GPSLOCATION - GPS Latitude, Longitude and Height

Result e.g. +50.762956:-001.539948:+4.90.

Where: +50.762956 is latitude ( $\pm 90$  degrees north/south), positive latitude equals north.

-001.539948 is longitude ( $\pm 180$  degrees east/west), negative longitude equals west.

+4.90 is height. Using GPS means that regardless of whether a station is located on a mountain or on the coastline of a country it is possible to compare pressure readings without any further calculations as the GPS information gives the height information needed to calculate the difference in elevation to sea level and then it is possible to correct the reading for it.

If GPS lock is lost, location reverts to set value or to GMT so the current location should be set manually.

## GMX560 Compact Weather Station

### GPSSTATUS - Location Fix and Number of Satellites

Result e.g. 010B.

Where: 0 is padding.

1 is GPS SPS mode fix valid (0 is fix not available).

0B is a hexadecimal representation of the number of satellites acquired, 11 satellites found. 0A would be 10 satellites etc.

### TIME (and Date) - MaxiMet Date and Time (can be updated by GPS Option)

Time can be set manually by the user or updated by the GPS Module (if fitted). GPS time can be automatically updated every hour (GPS default setting).

By default time will be UTC.

Result e.g. 2015-06-04T10:01:36.8.

### VOLT - Supply Voltage

DC Supply voltage measured at the MaxiMet.

Result e.g. +10.5 (volts).

### STATUS - Status of MaxiMet Sensors

Outputs the MaxiMet Sensors Status Code.

Result e.g. 0000 (see para 8.3).

### WINDSTAT - Status of Wind Sensor in detail

Outputs status codes relating to wind sensor data.

Result e.g. 0000 (see para 8.3).

### USERINF - User Information Field

The User Information field shall have a maximum size of 16 characters, comprised of printable ASCII characters (to exclude "@", ",", "\*", "%" and "?").



Space character may be included.

This field allows for instance to record installation or calibration dates.

Result e.g. CAL DUE 15.08.18



## GMX560 Compact Weather Station

### Glossary & Abbreviations

Item	Meaning
CAL	Calibration
CR	Carriage Return
CRLF	Carriage Return Line Feed
CSV	Comma Separated Variable
ENG	Engineering
ESC	ESCape key on keyboard.
ETX	End of string character
fpm	Feet per minute
GND	GrouND
HEX	HEXadecimal
I/P	InPut
IP66	Protection Classification
KPH	Kilometres per Hour
LF	Line Feed
m/s	Metres per Second
MAG	MAGnitude - scalar reference to wind speed
MAX	MAXimum
MIN	MINimum
MPH	Miles per Hour
NMEA 0183 (V3)	National Marine Electronics Association
No:	Number
NVM	Non-Volatile Memory
O/P	Output
PC	IBM compatible Personal Computer
PCB	Printed Circuit Board
ROM	Read Only Memory
RS232	Communications standard
RS422	Communications standard
RS485	Communications standard
RWA	Road Weather Averaging
RX	Receive
RXD	Received Data
S/W	Software
SDI-12	Serial Data Interface
SEC	SECond
STX	Start of string character
TERM	TERMinal
TX	Transmit
TXD	Transmitted Data
+VE	Positive
-VE	Negative
WRT	With Respect To

# MaxiMet<sup>®</sup> Marine

## GMX560 Compact Weather Station

### Appendix N - M12 to USB Configuration Cable installation

The M12 to USB Configuration Cable can be used to connect a MaxiMet Marine to a PC running MetSet software. This will allow the MaxiMet Marine to be configured and tested prior to installation. Please note that this cable should only be used to configure and test the MaxiMet Marine and should not be used in normal operation.

If the MaxiMet Marine is in default configuration, the M12 to USB Configuration Cable can be connected and the unit configured as required.

If the MaxiMet Marine is not in the default configuration (for example MODBUS or SDI-12) then the use of Safe Mode will be necessary. Details of safe mode can be found in Appendix E.

#### Determining M12 to USB Configuration Cable Com Port

To use safe mode it is necessary to determine the COM port that the M12 to USB Configuration Cable is assigned on the PC – this can be confirmed by opening Device Manager on the PC and checking the COM & LPT Port settings as shown:

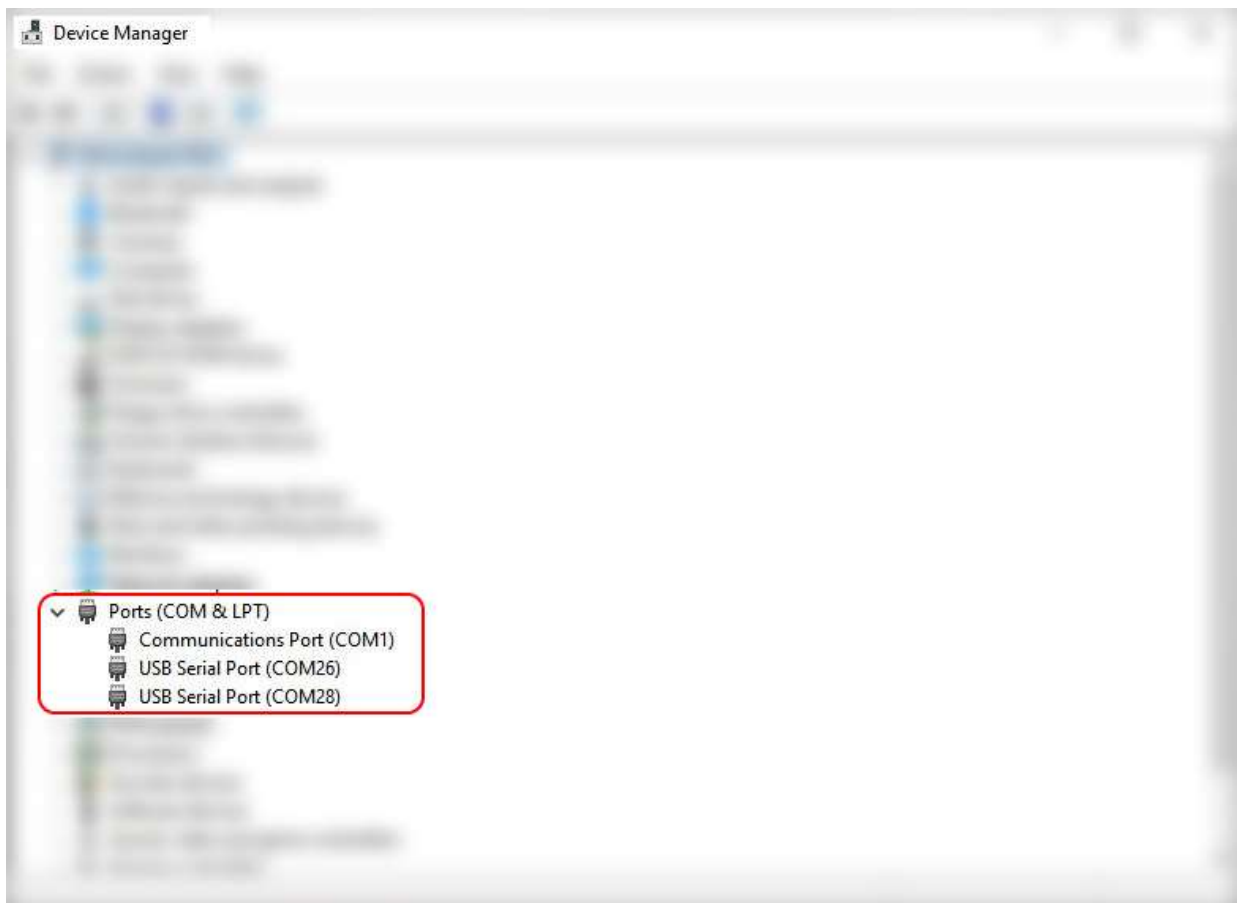

If no COM port is shown, it may be necessary to install device drivers (please contact Gill Instruments Technical Support if drivers are required).

**As a representative of this supplier,  
we – from Observer – distribute  
these products. Originating from  
the Netherlands, Observer has  
grown into an internationally  
oriented company with a worldwide  
distribution network.**

**For more information contact  
Observer Instruments:**

**Australia**

T: +61 3 8706 5000

E: sales.au@observer.com / service.au@observer.com

**Germany**

T: +49 (0)152 02047306 / +49 (0)152 02047308

E: contact@observer.com

**The Netherlands**

T: +31 (0)180 463411

E: sales@observer.com / service@observer.com

**Poland**

T: +48 537 209 665

E: a.miller@observer.com

**Singapore**

T: +65 68 72 08 63

E: sales@observer.sg

**United Kingdom**

T: +44 (0)783 346 4884

E: info.uk@observer.com

**Welcome to the world of Observer**

Since 1924 Observer has evolved to be a trend-setting developer and supplier in a wide variety of industries. Originating from the Netherlands, Observer has grown into an internationally

oriented company with a worldwide distribution network and offices in Australia, Germany, the Netherlands, Singapore and the United Kingdom.

[www.observer.com](http://www.observer.com)